

SCIENCE AND MECHANICS

RADIO-TV

Experimenter

A SCIENCE AND MECHANICS
50¢
PUBLICATION

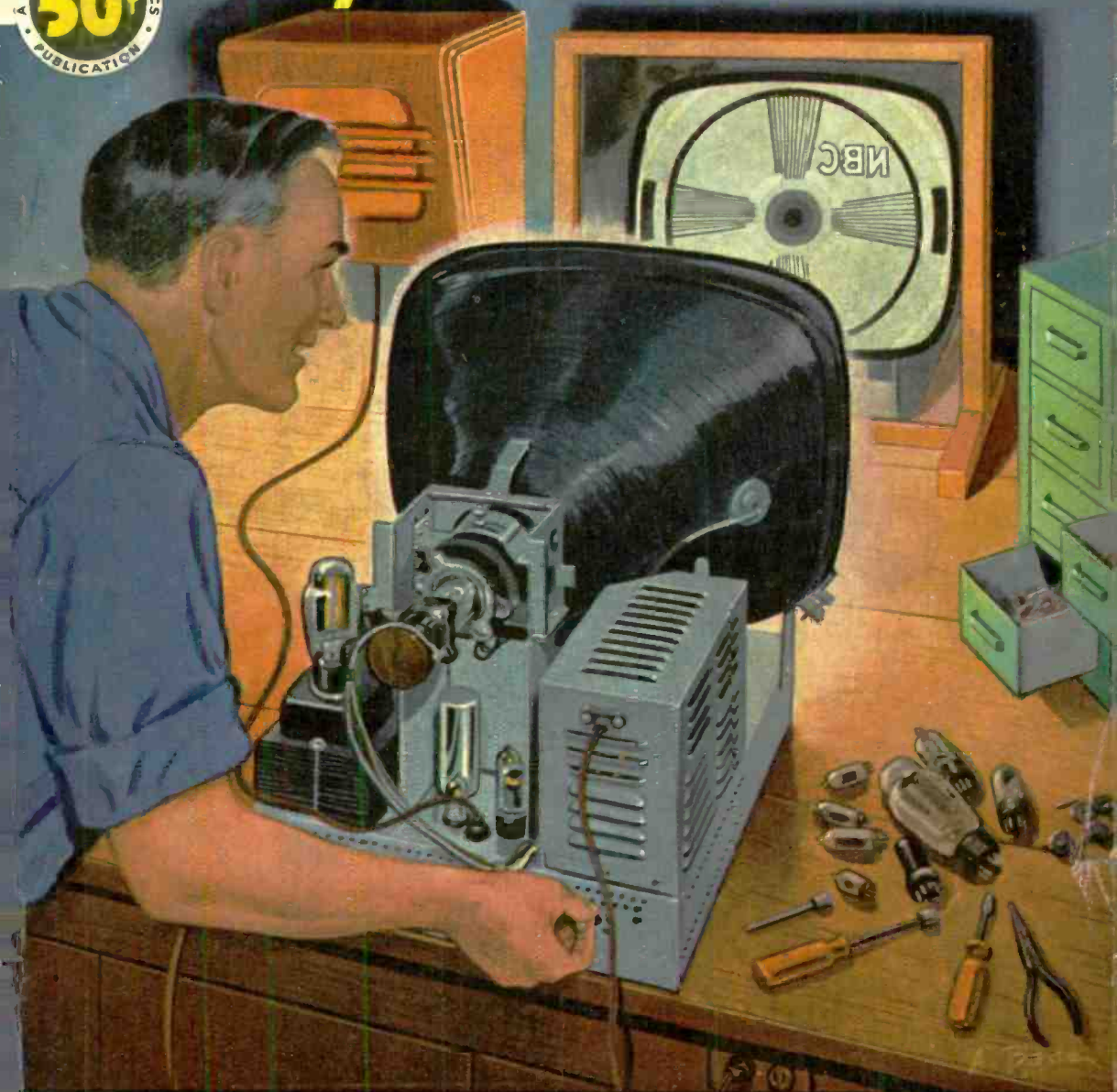

Over **40** **ELECTRONIC PROJECTS** — Radio-TV Servicing • Alarm Clock Radio
Talking Light Beam • Geiger Counter • Crystal, Battery and Superhet Receivers
Novice-class Transmitter • Light Controlled Model Boat • Electronic Organ
Short Wave Converter • Neon Glow Tube • FM Radio *plus many others.*

RADIO TELEVISION • ELECTRONICS

EXPERIMENTERS' KITS



SUPER-POCKET RADIO

ELECTRON TUBE TYPE—PLASTIC CASE \$3.95
Smaller than many hearing aids. Simple, unique kit anyone can assemble & wire. Long-distance, highly selective circuit. Up to 1500 mi. range. Local station's volume often too loud for comfort. Uses two inexpensive cells which fit inside plastic case. Complete kit, including tube only \$3.95. Battery & earphone available, extra. Supply limited—order now! M.C.O.B.
E. G. LITTLE, Mfrs., Springdale, Conn.

TV INTERFERENCE KIT

Builds Three Different Filters

If your TV pictures are ruined by streaks, ripples, and bars caused by motors, autos, amateurs, FM stations, X-Ray, diathermy, etc. a filter may help.

We can furnish a complete kit of all essential components for building all three TV Interference Filters described in this manual. You get iron cores, paper capacitors, mica or ceramic capacitors, coil wire, bakelite plates, etc. for Power Line Filter (less box), Ignition Filter, and High Pass Filter. **TV FILTER KIT ONLY \$2.95 postpaid.**

TV PIX TUBE RESTORER

Revives Dim Worn-Out Screens

Don't invest up to \$75 for a new TV picture tube just because it has gone dim through long, hard use. Your old tube may be good for another 3000 hours life simply by plugging in a cathode emission restorer between TV set and picture tube socket. Attached in one minute! No tools required.

Works on all sets from 10- to 30-in. sizes. Not a gadget, but a device based on sound electronic theory. **PIX TUBE RESTORER ONLY \$3.75 postpaid.**

WIRELESS BROADCASTER AND RADIO SET \$3.99

Twenty times more powerful than heat crystal set. Louder than many sets with several tubes. Highly selective. Works anywhere on two inexpensive batteries.

This new Blanchard design is a honey! Complete kit, including tube as shown, only \$3.99, postpaid anywhere. (Phone and batteries extra.) Picture plans included.
E. G. Little, Mfrs., Springdale, Conn.



ELECTRONIC MAGIC KIT PROVIDES 101 EXPERIMENTS

Builds experimental Ray Detector, Metronome, "Electric Eye," Stroboscope, Pocket Electric and Radio Tester, Code Practice Set. Even produces electronic music! Kit includes pee-wee gas tubes, resistors, potentiometers, capacitors, rectifier, etc. Works on 115 AC-DC—no battery expense! Kit of all necessary components (less headphones) ONLY \$3.95 postpaid. Order from this ad while supply lasts.
E. G. LITTLE, Mfrs., Springdale, Conn.



RADIO "INTERCOM" CONVERTER

Converts Radios to Wireless Intercom

Small home radios may be used for two way communication with the Intercom Converter described in this manual. Or a single Converter may be attached to just one set for use as a "home broadcaster". A flip of the switch changes speaker to dynamic mike, and set to a modulated oscillator.

We furnish a complete kit of parts for assembling a converter unit just as pictured elsewhere in this manual. **INTERCOM CONVERTER KIT ONLY \$3.95 postpaid.**

ELECTRONIC CONTROLS

Kits and Custom-Built Devices

We can supply a complete kit of parts (less tubes) for Control shown in Fig. 5 "Putting Electric Eyes to Work" for just \$4.95. Tubes and cabinet available at modest extra cost.

Special electronic apparatus for medical, industrial and research use our specialty. We design and/or build, for all scientific professions, finished models or production run devices from freehand sketches.

Queries on company or professional letterhead will receive prompt attention.

POCKET CRYSTAL RADIO

Powerful and Highly Selective

This vest-pocket crystal radio employs a diode detector with amazing ferrite coil, with both inductive and capacitive tuning. Kit includes all components to assemble this amazing set (except headphones) at bargain price of \$2.99.
E. G. LITTLE, Mfrs., Springdale, Conn.



FERRITE RADIO COILS

"Supercharges" Small Sets

This amazing coil replaces old loop in AC-battery portable or table sets. Brings in stations often never heard before. This coil used in many projects described in this manual. Installed in a couple minutes. Only 99c postpaid.
E. G. LITTLE, Mfrs., Springdale, Conn.

ONLY 99c



BASIC SUPERHET RADIO KIT

Want to build the Clock Radio, Battery Portable, or modernize a junk set as described in this manual? We can supply a kit containing these basic items for only \$4.95: Ganged Superhet Tuning Condenser; Matched Pair I.F. Transformers; Ferrite Antenna Coil; Volume Control; and five 7-Pin miniature water sockets.

Other radio-TV-electronic components available if needed. State in your order and we will quote, or ship additional items C.O.D., plus postal fee.

ACCESSORIES

Sensitive Double Headsets, \$2.25 pair. PM Speakers, \$2.50. Speaker Transformers, 89c. Midget Radio Soldering Irons, \$1.98. Special radio solder, 25c hank. Heavy aluminum boxes for experimenters (5x3x2-in.), \$1.00 Aluminum (soft) for panels/chassis, 5x5-in. plates, \$1.40; 4-cage, 49c. 5x10-in. plates, 89c. 5x16-in. plates, \$1.29. Plastic boxes (heavy-clear acetate) size 3x3x1-in. 39c ea. Sensitive electronic control relays, 5000 ohms, SPST (norm. open) \$1.98. Add 10c to above items for postage. Postage free if ordered with kits.

POCKET TUBE CHECKER

Locates TV-Radio Tube Defects

This kit contains all necessary components for assembling the Pocket Tube Checker described in this manual. Tests hundreds of types of radio and TV tubes for shorts, burn-outs, etc. Also functions as radio-electrical continuity tester. Parts and purchased aluminum panel ready to wire and mount in your own box ONLY \$2.99.
E. G. LITTLE, Mfrs., Springdale, Conn.



HOW TO ORDER

Remit by postal, express, or currency exchange money-order, check, or cash (at your risk). C.O.D. orders must include \$1 deposit. Please order from this page as we do not publish a catalog. Complete details on kits are in this manual.

E. G. LITTLE, Mfrs.

BLANCHARD ELECTRONIC PRODUCTS
SPRINGDALE 1, CONNECTICUT

HOBBY HOBNOB

ED, HOW DID YOU GET STARTED IN THE RADIO HOBBY?

I ANSWERED A *Walter Ashe* AD AND GOT THEIR **FREE** CATALOG. IT'S CRAMMED FULL OF SWELL RADIO AND TV KITS AND EQUIPMENT.

THIS LITTLE RADIO KIT IS OUT OF THE CATALOG. PUTTING IT TOGETHER IS FUN AND IT'S EASY!



I'M GETTING MORE DISTANCE WITH THIS THAN YOU DO WITH YOUR SMOKE SIGNALS

WRITE FOR YOUR FREE CATALOG TODAY

USE THIS HANDY COUPON

All prices F. O. B. St. Louis • Phone Chestnut 1125

Walter Ashe
RADIO CO.
 1125 PINE ST. • ST. LOUIS 1, MO.

Walter Ashe Radio Co. SM-REH-52
 1125 Pine St., St. Louis 1, Mo.

Please place my name on your mailing list to receive latest catalog.

Name _____

Address _____

City _____ Zone _____ State _____

Wade

RADIO-TV

Experimenter

VOLUME TWO

How to Make Simple TV Repairs.....	9	Dress Up that Low Priced Record Player.....	108
Three Speeds from a Two-Speed Phono Motor.....	16	Inject New Life Into Junked Radios.....	109
Supercharge Your Small Radio.....	17	Pocket-Size Uranium Detector.....	113
Converting Your Small-Screen Set to a 16 in. TV Receiver.....	19	Twin Speakers Improve Fidelity.....	116
Big Picture TV.....	23	Loop Crystal Set.....	117
General Purpose AC Amplifier.....	27	Dual Purpose Amplifier.....	119
Alarm Clock Radio.....	30	One Tube Electronic Metronome.....	122
Safety Power Pack.....	34	Versatile Oscillator.....	124
Do You Pay Too Much for TV Servicing?.....	36	Super-Midget Portable.....	127
Power-Line Antenna for Crystal Set.....	41	Improving Loudspeaker Performance.....	130
Listen with a Transducer.....	42	Pocket-Size Tube Checker.....	131
Trapping that TV Interference.....	43	Miniature Multi-Purpose Sound System.....	133
Pint-Sized Loudspeaker Radio Receiver.....	45	Wireless Pickup Amplifies Phone Talks.....	135
Simple Frequency Shifting.....	47	Record Player Built in a Drum.....	137
TV Interference Suppressor.....	48	Two-Tube Battery "DX-er".....	139
Flashlight Makes Continuity Tester.....	50	Headlight-Controlled Garage Door Opener.....	142
3-in-1 TV Control.....	51	Plug-In Atom Bomb Radiation Alarm.....	147
Build a Turntable for Your TV Receiver.....	52	Portable Radio and Hearing Aid Batteries.....	150
Wireless Radio Intercom Converter.....	53	Electronic Organ.....	152
Micro-Switch Telegraph Sounder.....	55	Putting 'Electric Eyes' to Work.....	156
Versatile Radio Frequency Indicator.....	56	Audio Amplifier.....	160
Pick the Right Antenna for Top TV Reception.....	59	Portable Superhet.....	163
Low-Loss Uniform-Impedance Antenna Switchboard.....	63	Precision Electronic Timer.....	168
Radiotelegraph Station for "Novice" Operators.....	64	Electron III.....	172
Vestpocket Crystal Radio.....	70	Magic Arm Record Player.....	183
Talking on a Light Beam.....	72	Radio Symbols.....	186
Extension Speaker.....	75	Useful Tables and Formulas.....	187
TV Antenna Couplers.....	76		
Remote Control with Selsyn Motors.....	78		
Portable Di-Poles for TV and FM.....	80		
Tapped Coil Crystal Set.....	83		
Experimenting with Neon Glow Tubes.....	86		
Short-Wave Converter.....	91		
FM Tuner with Sensitivity.....	94		
Wireless Broadcaster.....	97		
You Can Fix that Ailing Radio.....	100		
High-Powered Pocket Radio.....	105		
Aluminum Folding Rule Antenna.....	107		

V. D. ANGERMAN
Editor and Publisher

DON DINWIDDIE
Managing Editor

MERLE E. DOWD
Home Workshop Editor

P. D. URBAIN
Associate Editor

L. G. ANDERSEN
Associate Editor

F. M. EISENZOPH
Art Director

Cover by Arthur C. Bade

Now IN YOUR OWN HOME *Learn*

TELEVISION RADIO

the Amazingly Effective
D. T. I. WAY

—with the aid of **BOTH**
HOME EQUIPMENT
and **HOME MOVIES**

NO PREVIOUS EXPERIENCE NEEDED
NOW...get
EVERYTHING
YOU NEED
for real Laboratory-
Type training
AT HOME

Above:
Work over
300
fascinating
experiments
with this
equipment

1. Build over 300 fascinating experiments from 16 BIG SHIPMENTS of Electronic-Radio parts which you KEEP.

2. Build valuable commercial-type test equipment—as shown to the left—which you KEEP. This includes a quality OSCILLOSCOPE—a must for television work.

3. Use a 16 mm. movie projector and new series of Hollywood produced instructive movies—a wonderful aid to help you grasp important fundamentals faster...easier...better.

4. Enjoy well-illustrated, easy-to-read lessons with handy FOLD-OUT diagrams.

5. Get an honest-to-goodness EMPLOYMENT SERVICE to help you get a good job after graduating—or assistance in starting your OWN SALES AND SERVICE BUSINESS. Mail coupon today for the complete details.

What will mailing the coupon below *do for YOU?* Just this! You'll find out about one of today's most remarkable... practical ways to prepare to get into America's amazing billion dollar opportunity field of TELEVISION-RADIO-ELECTRONICS. You'll see how to get into fascinating work that pays well... that offers one of America's most promising futures... that enables you to start your own business almost "on a shoestring," if you prefer this to a job opportunity.

And above all, you'll get some GOOD NEWS especially welcomed by men anxious to earn REAL MONEY in this thrilling field. For you'll see that NOW you can get the kind of practical, laboratory-type training so desirable for making real progress in Television-Radio-Electronics... and WITHOUT LEAVING HOME.

You'll see that DeForest's Training, Inc. sends everything needed to set up your own HOME LABORATORY. You get and keep the same type of basic electronic equipment used in our modern Chicago Training Laboratories. You get home training that includes the knowledge and experience gained from training thousands of students first hand in Chicago. And to top it all, you use DTI's amazingly effective and exclusive home training aid—INSTRUCTIVE MOVIES. But why not get the complete story? Mail coupon today for information-packed literature.

MODERN LABORATORIES

If you prefer, get all your preparation in our new Chicago Training Laboratories—one of the finest of its kind. Ample instructors, modern equipment. Write for details!

MILITARY SERVICE!

If you're subject to military service, the information we have for you should prove very helpful. Mail coupon today.

Get **BOTH** of these colorful, information-packed folders **FREE**

89 WAYS TO EARN MONEY IN TELEVISION

YOU GET ALL 6

Mail Coupon Today

DeFOREST'S TRAINING, INC. REX-1952
2533 N. Ashland Avenue, Chicago 14, Ill

I would like valuable, information-packed folders showing how I may get started toward a good job or my own business in Television-Radio-Electronics.

Name _____ Age _____
Street _____ Apt. _____
City _____ Zone _____ State _____



DeFOREST'S TRAINING, INC.

AFFILIATED WITH
DeVry Technical Institute
CHICAGO 14, ILLINOIS

Let me send you this amazing- ELECTRONIC KIT!

OWN THIS ELECTRONIC KIT

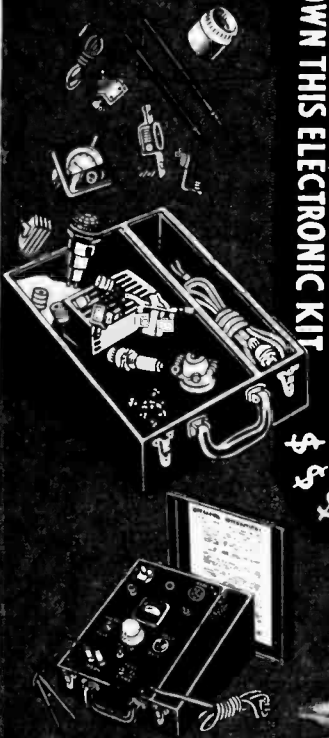

ASSURE YOURSELF OF FINANCIAL SECURITY—INDEPENDENCE

Imagine being able to fix anything electrical from the tiniest home electric shaver to large industrial motors! Having a training that makes you command a better job with higher wages or a business of your own. You do not need previous special schooling. Just the ability to read and be mechanically inclined. We furnish you with everything! One of the kits sent to you is our famous ELECTRONIC KIT, an all-purpose trouble detector which shows you where the trouble lies. Training kits whose assembly will give you practical shop training at home during your spare time!

You learn practical electricity by using your hands. Best of all, these kits are yours to keep and use forever! !

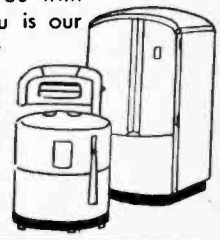

R. S. FRAZER

REPAIR ELECTRICAL EQUIPMENT!

ILLUSTRATED COURSE SHOWS EVERYTHING

The Christy maintenance and repair course is written in simple, easy-to-understand language. Each section is profusely illustrated by photographs and drawings and shows you what troubles to look for and then how to correct them. In addition, our course shows you how to build power tools at low cost. Also teaches you welding, nickel plating, general repairing (saw filing, bicycle and gas stove repairing, etc.). Should complicated technical problems arise or the need for a special repair part, simply call on us. We offer YOU our FREE Advisory Service for LIFE! We teach you how to al'cit business, get repeat orders and what to charge. The Christy Course plus our home shop training kits make a combination that will go a long way toward ASSURING YOUR SUCCESS.

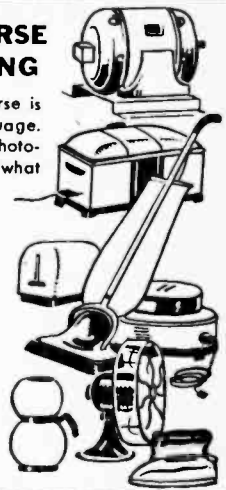

3 EASY STEPS TO SUCCESS

- ① WE SEND YOU AN ELECTRIC KIT
- ② WE TEACH YOU ELECTRICAL APPLIANCE REPAIRING
- ③ WE GIVE YOU LIFE-TIME ADVISORY SERVICE

RUSH THIS COUPON TODAY!

CHRISTY TRADES SCHOOL, Dept. D-111
4432 N. Kedzie Ave., Chicago 25, Ill.

Please send me your FREE book on Electric Equipment Servicing and instructions for paying later from EARNINGS WHILE LEARNING!

Name..... Age.....
 Address.....
 City..... Zone..... State.....



AMAZING NEW 2-FOR-1 OFFER

BE A LICENSED* TV TECHNICIAN

LICENSED TV MEN MAKE MORE MONEY

COMPARE RTTA'S EXTRA FEATURES

1. I furnish you ALL parts and equipment to build 15 big units, including your own COMPLETE TV RECEIVER. At the same time, I give you the training that will qualify YOU as a TV TECHNICIAN in America's booming TELEVISION & Electronics industries... *within months*, studying at home. Many of my students pay for their entire training from spare time earnings installing and servicing Radio-TV sets... start their own business.
2. Then—after you finish your training for a position as a full-fledged TV Technician... I help you qualify for the *better pay BETTER JOBS* that demand an FCC license, with my...

FREE*FCC COACHING COURSE

- Prepares you for your FCC license
- Included at NO EXTRA COST

The Best Jobs in TV & Radio Require an FCC License

ROUND TRIP TO NEW YORK CITY—FARE FREE!

Yes, I pay your way to New York and return from wherever you live in the U. S. or Canada, after you finish your home study course. I give you two free weeks—50 hours of advanced instruction and shop training at the *Pierce School of Radio & Television*. You use modern electronics equipment, including student-operated TV and Radio stations. You go behind the scenes of New York's big Radio-TV centers—to study first hand. And I give you all this AT NO EXTRA COST! (Applies to complete Radio-TV course only.)

VETERANS!

Eligible under new G.I. Bill? Be sure to check coupon below!

GOING INTO UNIFORM?

Learn how you can qualify for military specialist ratings, and higher pay!

MY GRADUATES HOLD GOOD PAYING JOBS

- "Thanks to your training, I qualified for a good job as a Receiver Tester at Federal Telephone and Radio."
—Paul Frank Seler
- "Your excellent instruction helped me get my present job as an airport radio mechanic for American Airlines."
—Eugene E. Gasko
- "I'm making good money in my own business, repairing and installing radio and TV sets — thanks to your training."
—Irwin Polansky
- "I'll always be grateful to your training which helped me get my present fine position as Assistant Parts Manager."
—Norman Weston

RADIO-TELEVISION TRAINING ASSOCIATION

Approved as a Correspondence School under the laws of the State of New York

1629 Broadway, Radio City Station, New York City 19, N. Y.

YOU BUILD AND KEEP THIS LARGE SCREEN TV RECEIVER . . . included with my 15 big Radio-TV kits Everything Furnished At No Extra Cost

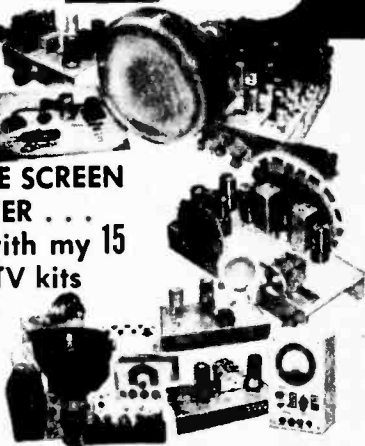

NOW! Advanced FM-TV Training For Men Who Know Radio

Prepares You For Higher Pay Jobs In A Few Months

COMPLETE theory and practical training course . . . complete with kits including large screen TV receiver.

FCC License Coaching Course Included FREE.

MY SIMPLE METHODS MAKE SUCCESS EASY!

I have helped hundreds of men—most of them with NO PREVIOUS TRAINING—get ahead in TV. Even with a grammar school education, you can master my practical methods where you use actual parts and equipment and "learn by doing".

BIG MONEY IN TELEVISION FOR YOU

PREPARE NOW for the thousands of new job opportunities that will be available for you right in your home state, with lifting of government restrictions on new TV stations. As a well-trained technician, you can write your own ticket . . . get more success and happiness out of life. Don't delay. Mail the coupon today, and let my FREE BOOKS show you how easy it is.

NO SALESMAN WILL CALL!

Mr. Leonard C. Lane, President
RADIO-TELEVISION TRAINING ASS'N
1629 Broadway, Radio City Station
New York 19, N. Y. Dept. E-10

Dear Mr. Lane: Mail me your two new books about your amazing 2 for 1 offer with no obligation to me. I UNDERSTAND NO SALESMAN WILL CALL.

BOTH FREE! SEND NO MONEY! MAIL NOW FOR MY NEW FREE BOOKS!

NAME _____ Age _____

ADDRESS _____

CITY _____ ZONE _____ STATE _____

I am interested in:
 Radio-TV Advanced FM-TV

VETERANS! If qualified under G.I. Bill, check here

Today's Best Buy!

With prices going up right and left, SCIENCE AND MECHANICS still offers you the same big, 224-page magazine for only 20c a copy at newsstands, or by subscription, 12 issues for \$2.00 or 24 issues for \$3.50.

And what a bargain! You actually get more editorial pages, more illustrations, more "how-to-do-it" articles for your money than in any other mechanical magazine. That's why SCIENCE AND MECHANICS is now selling over 700,000 copies on the newsstands. For the latest scientific and mechanical developments, for variety in craft projects, for thoroughness and accuracy. SCIENCE AND MECHANICS is "tops." Subscribe NOW before the subscription price goes up!

12 BIG ISSUES
Only \$2.00



Just Look at the Wealth of Information You'll Find in Every Issue

New Products for Home, Office and Shop; New Ideas from Industry; What's Happening in the Industrial Field; Scientific Tests of the New Model Automobiles under Laboratory Supervision (at least three cars in each issue); Basic Woodworking Methods, Furniture Projects, One-Evening Projects; Home Building, Repairing, Remodeling, Maintenance; Metal Working; Building Photo Equipment; Electricity; Radio and TV projects; Boats; Plastics; Patents and Inventions; Shop Kinks; Auto care, repair and maintenance, etc., plus hundreds more. And, each of these articles is written by an expert in his particular field—a man who knows his subject backwards and forwards, and also knows how to tell you how to do the job right. Scores of photos, drawings and step-by-step plans make every job crystal clear. That's why SCIENCE AND MECHANICS is called "The Magazine That Shows You How." That's why SCIENCE AND MECHANICS is the fastest growing of the mechanical magazines . . . and your best buy.

SCIENCE AND MECHANICS MAGAZINE
450 East Ohio Street, Dept. R-252, Chicago 11, Illinois
O.K.—Here's my \$2.00 (Canada, \$2.50; Foreign, \$3.00) for the next 12 big issues of SCIENCE AND MECHANICS. Please start my

subscription with the _____ issue.
 24 Issues, \$3.50 (Canada, \$4.50; Foreign, \$5.50)

NAME _____
ADDRESS _____
CITY, ZONE and STATE _____

2 ISSUES FREE

By subscribing now, you get the next 2 big issues of SCIENCE AND MECHANICS for only \$2.00. If purchased at newsstands at the regular price of 20c each, they would cost you \$2.40. Hence, you get the equivalent of two issues free. Further, you avoid the inconvenience of buying each new issue as they appear and you get your copy before it goes on sale at the newsstands. Save time and money by sending your subscription today. Use the handy coupon.

Send Today



TV data sheets, complete set of replacement tubes and accompanying Trouble Guide will help you remedy up to 80% of TV set's picture and sound defects.

HOW TO MAKE SIMPLE TELEVISION REPAIRS

By T. A. BLANCHARD

A FLECK of "Fix Your Own TV" books flooded the market during 1951 and 1952. Most of these books contained some useful information, but no book can make you a TV expert overnight. In typical medicine show pitchman style, unethical promoters hinted that every radio and TV serviceman was a highway robber. Needless to say, all servicemen are not gyps! It takes only one bad apple to spoil a barrel!

Some troubles that plague TV sets call for complex test equipment that only a reliable serviceman can afford. But anyone with a *working knowledge* of radio can remedy up to 80 percent of the troubles that develop within his TV set by

Up to 80% of the troubles experienced with quality-built TV sets can be corrected in minutes by following these logical steps.

following the accompanying TV Trouble Guide. In addition to the TV Trouble Guide, you will also need the following: (1) Schematic, chassis arrangement and all service data for your set. (2) A complete replacement set of tubes for your set to be kept on hand for the time when one or more tubes are needed. (3) A radio tube manual.

A trouble guide, alone, is like a man who buys a safe but doesn't get the combination to open it. TV sets purchased from a mailorder house usually include technical data and chassis tube arrangement packed with the set. Nationally advertised sets, however, seldom contain anything more than a small operating booklet and the chassis tube layout glued or tacked inside the cabinet or on the bottom.

Manufacturers who fail to provide these vital facts cause the public to pay for the time a serviceman spends on research plus actual labor and parts.

Even when one of the corrective measures from the TV Trouble Guide fails to remedy a defect in your set, advising the serviceman where the trouble seems to be can save you

real money. Having complete service data on your set will save the serviceman a trip to his shop to get the circuit dope he needs to restore your set to operating condition.

How to Get Technical Data. Complete technical data with chassis photos (top and bottom views), schematic diagram, tube locations and function, and alignment data are sometimes available free from small TV set makers and mailorder merchandisers. Otherwise, you can obtain these technical data on just about any TV set ever made from either of two respected technical publishers. These data are complete and were compiled by experts working with the engineering depart-

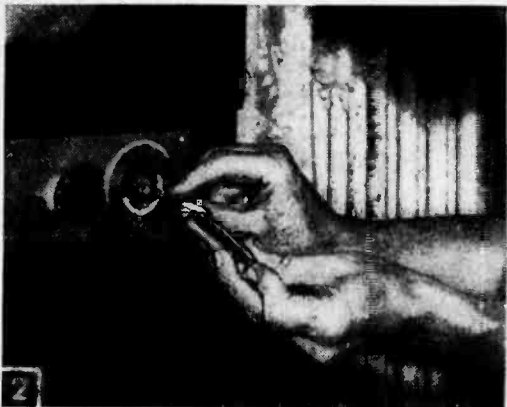

Simple oscillator slug adjustments on turret tuner are made by pulling off channel selector and fine tuning knobs. Plastic blade screwdriver and penlite are all the tools you need for amazing reception improvement.

ments of the TV manufacturers. The data for each make and model come in a separate packet modestly priced.

Before buying data for your set, obtain their free index and price list. Two hundred sets of folders, trademarked "Photofact," are published by Howard W. Sams & Co., Inc., and are available through more than 1000 distributors of radio and TV parts in the U.S. and Canada or by mail from radio and TV parts suppliers. Another series of folders, "Tek-File," is available from John F. Rider, Publisher, Inc., 480-B Canal St., New York 13, N. Y. Check your TV set's nameplate for model and serial no. against the listing in the free index to be sure of getting the correct packet.

Before going ahead with servicing instructions using the TV Trouble Guide, you should remember these safety rules—(1) Do not touch or remove the high-tension cable at side of picture tube when power is ON. Before touching anything inside the high voltage cage, discharge the unit by grounding the caps of the H.V. rectifier and horizontal output tubes with an insulated screwdriver by touching the screwdriver blade from the tube caps to the chassis. (2) Do not use a "cheater" cord in order to operate set when the cover of H.V. cage is removed. This interlock was designed for your safety, nothing else! (3) Do not handle picture tubes by

the neck and do not drop pliers, or heavy tools on the picture tube. These tubes are exhausted of all air and external air pressure on the glass is terrific! When working on chassis removed from the cabinet, wear safety glasses or cover tube with a light blanket to thwart damage of flying glass if it should break. (4) Never tamper with the slug screws on I.F. transformers (these are located atop the small aluminum cans near the I.F. tubes, or flush with chassis between I.F. tubes.)

Types of TV Sets. TV sets vary from one another mechanically and electronically, but all are alike in theory. Fig. 4 shows the two popular types of circuits. Fig. 4A shows the separate sound I.F. and Fig. 4B shows the intercarrier I.F. In the separate sound system, the AM signal (picture) and FM signal (sound) go their separate ways after passing the mixer tube in the R.F. tuner. However, in intercarrier circuits, sound and picture signals use a common I.F., separating at the video detector or video amplifier.

Therefore, the intercarrier circuit requires fewer tubes than the separate sound circuit, all other conditions being equal. The intercarrier circuit is easier to service but has one marked objection—improper adjustment of the ratio detector transformer or slug in the oscillator and of tuner causes a buzz on strong stations.

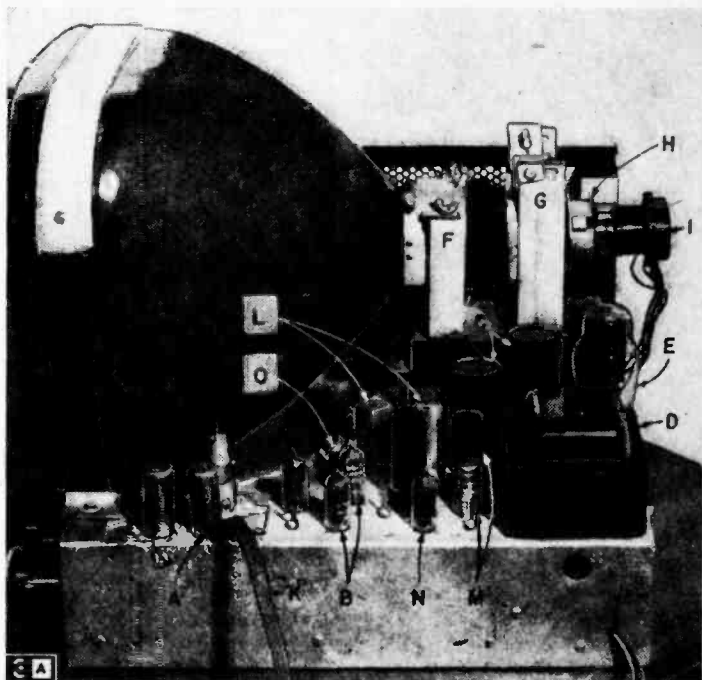

Location of components on a typical TV chassis. (A) Flush-mounted turret tuner and shielded R.F. and oscillator-mixer tubes. (B) I.F. intercarrier stages and tubes. (C) Low-voltage electrolytic filter capacitors. (D) Low-voltage power transformer. (E) Low-voltage rectifier tube. (F) Deflection yoke and mounting bracket. (G) Focus coil and mounting bracket. (H) Ion trap. (I) Picture tube socket. (J) Dynamic speaker cable. (K) Antenna cable to tuner. (L) Cans contain "sound take-off" and ratio detector transformer. (M) Shielded video detector; behind it, metal video amplifier tube. (N) Ratio detector-driver; behind it, metal audio output tube. (O) Ratio detector with audio amplifier to right and behind metal audio output tube.

GET A HIGH-PAYING JOB IN RADIO AND TV



EXAMINE THESE BOOKS FREE!

QUALIFY FOR 1ST CLASS FM-TV FCC LICENSE WITH THESE BOOKS



TELEVISION SIMPLIFIED

This brand-new 1952 book contains no involved mathematics. Everyone alert to the practical opportunities in television can profit from this completely up-to-date, easily understood presentation of television—from the analysis of circuits and operating fundamentals to repair. Hundreds of vivid illustrations bring every fact and point right before your eyes. You will be amazed at how simple television can become with this authoritative handbook.

\$6.50

FM SIMPLIFIED

Here are complete procedures and instructions for every step of constructing, installing, operating, and servicing FM equipment. You get clear, easy-to-understand explanations of fundamental principles, plus detailed analysis for the component units of each set, with a full explanation of circuit construction and relationship. Diagrams, drawings and illustrations guide every step of your way.

\$6.50

347 pages

TELEVISION AND FM RECEIVER SERVICING

Here is the most economical, up-to-date and completely practical manual available to servicemen. Gives you specific direction for installing television receivers, and for diagnosing, locating and repairing the common troubles of FM or television receivers. Complete alignment and servicing instructions are given at each point of a logical step-by-step procedure. Packed with valuable schematic diagrams and photographs.



\$3.25

UHF RADIO SIMPLIFIED

This clearly-written book is a logical presentation of UHF radio—from basic principles of ordinary radio circuits to a thorough explanation of the principles and applications of ultra-high-frequency radio, including all types of equipment. Profusely illustrated.

\$4.50

● These famous Kiver manuals are used the world over in television stations, repair shops, engineering offices and trade schools. Let them prepare YOU for the high-paying opportunities in radio and TV. Send for your free-examination copies today!



MAIL COUPON TODAY!

D. Van Nostrand Co., Inc., Dept. RE-52
250 Fourth Avenue, New York 3, N. Y.

Please send me for 10-day free examination the book or books I have checked below. After 10 days I will either return the book or books and owe nothing, or I will send you the full purchase price plus postage.

Television Simplified	\$6.50
FM Simplified	6.50
Television and FM Receiver Servicing	3.25
UHF Radio Simplified	4.50

Name

Address

City

Zone

State

(SAVE MONEY! If you send purchase price with this coupon we will pay postage. Same return privilege; refund guaranteed.)

FREE 10-DAY TRIAL

Mail the coupon at right for free-examination copies of any or all of these great books. Look them over without charge or obligation; return them if not completely satisfied.

JUST OUT! 4 NEW HANDBOOKS!



Hundreds of Useful Things to Build—
Scores of Ways to Save Money on
Home Repairs—Ideas For Gifts—
Practical "How-to-do-it" Handbooks

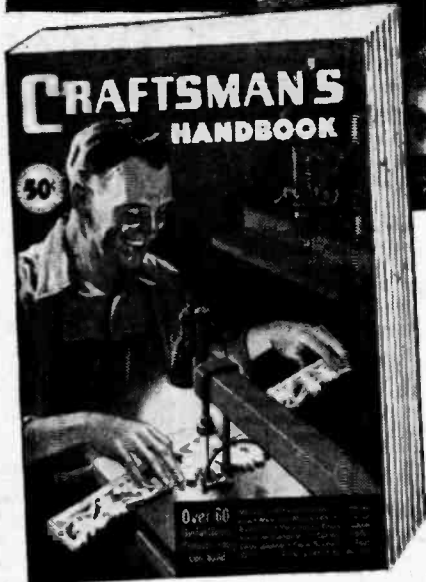
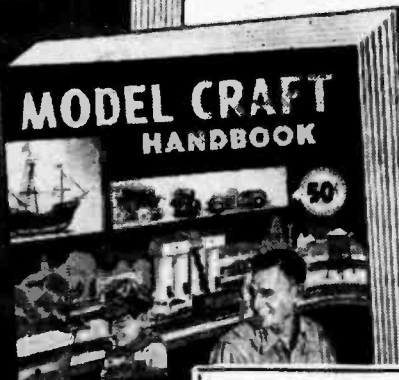

HOME OWNER'S HANDBOOK

Brings over 65 practical articles on Remodeling, Weather-proofing, Insulating, Heating and Wiring, Installing TV Sets, Laying Shingles, Home Gardening, Building Modern and Period Furniture, Making Storm Sash and Screen, plus a new series of attractive house plans. 192 pages. Price, 50c.

MODEL CRAFT HANDBOOK

Select Collection of 44 Model projects every craftsman will enjoy building. Includes Model Coaches, Model Railroad and Circus Equipment, Old-Time and Modern Automobiles, Ships and Small Boats, Model Airplanes, Working Jet, Gas and Steam Engines, Famous Guns, etc. 192 pages. Price, 50c.

CRAFTSMAN'S HANDBOOK

Over 60 Useful Home Projects You Can Build—Modern and Period Furniture, Power Lawn Mower, Movie Titler, Sail Boat, Binoculars, Veneering, Plaster Casting, Versatile Dark-room, Camping Trailer, Electroplating, Clock Repairing, Toys, Wall Safe, Pantograph, Bird Houses, etc. 192 pages. Price, 50c.

SHOP MECHANIC'S HANDBOOK

How to make and use Home Workshop Tools with over 65 "how-to-build-it" projects including Woodworking Lathe, Butt and Arc Welders, Power Sander, Paint Sprayer, Bench Grinder, Rotary Pump, Tool Demagnetizer, Lawn Mower Sharpener, Soldering Transformer, Workshop and Workbench Plans. 192 pages. Price, 50c.

ORDER TODAY

Add these four fine handbooks to your library of **SCIENCE AND MECHANICS** publications. They are a tremendous value at just 50c each, or all four for \$2.00. Send your order today to **SCIENCE AND MECHANICS**, Dept. R-352, 450 E. Ohio St., Chicago 11, Ill.

SCIENCE AND MECHANICS

450 East Ohio Street

Chicago 11, Illinois

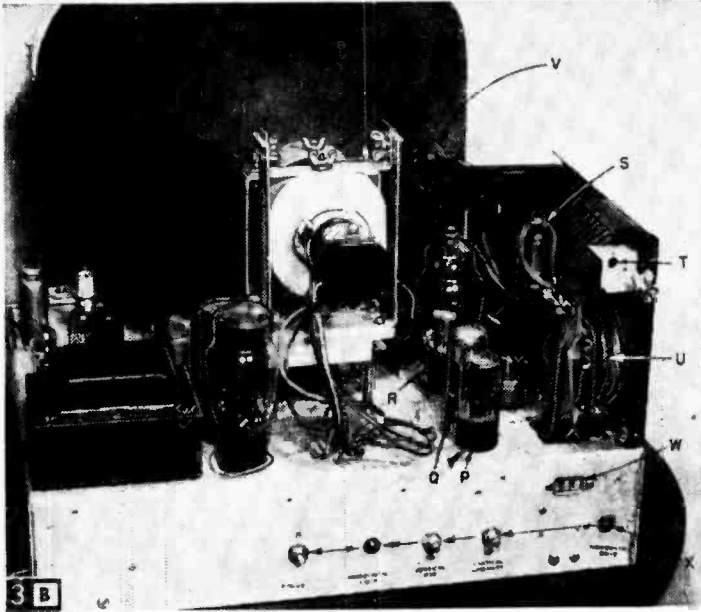

Fig. 3B shows (P) Horizontal sweep oscillator. (Q) Damper tube. (R) Horizontal sweep oscillator. (S) High-voltage rectifier. (T) Width control. (U) Horizontal output and high-voltage transformer (flyback). (V) 10 to 20,000 volt cable to picture tube. (W) Safety interlock power connector. (X) Picture size, linearity, focus, lock and frequency adjustments on rear chassis apron. Some sets are designed with these controls on front panel, reached by opening hinged nameplate panel in center of cabinet. Note: Three other tubes hidden by H.V. cage are the vertical sweep oscillator and output, horizontal phase detector, synchro, amplifier-splitter, and d-c restorer-synchro. clipper.

The separate sound circuit can usually be identified by the number of tubes employed in a TV set, usually about 30 tubes. Sets with 25 or less tubes are usually *intercarrier* types.

Tuners. Tuning a TV set to any one of the 12 standard channels is accomplished by one of the following tuners which differ from one another mechanically—electronic functions (discounting efficiency, or Q) are identical.

Variable Inductance Tuner—a continuous tuner with oscillator and R.F. coils varied over the frequencies of 54 to 216 mc. by silver-plated phosphor bronze wipers traversing spiral silver wire coils on a ceramic drum.

Variable Capacitance Tuner—a continuous tuner with oscillator and R.F. coils' frequency determined by adjustment of low capacity ganged "air" tuning capacitors.

Turret Tuner—most popular of all tuners because of its high-Q cascode circuit and rapid channel selection features. The turret tuner is not a continuously variable type but includes a fine-tuning adjustment inside the main channel selector knob. The 3 in. dia drum of the turret tuner is divided into 12 *staves*, each pre-tuned to a given channel. On each *staff* is a brass slug-tuned oscillator coil and pre-tuned R.F. coil. These *staves* may be snapped out and replaced with a UHF strip to receive the new TV signals.

Some turret tuners employ "printed" circuits,

and use some air-wound coils. All turret tuners function the same way and include provisions for adjusting the oscillator coil frequency either by turning a brass slug or a screwdriven compression plate.

Early TV sets employed 12 stationary coils which were "cut into" the set by rotating a multipole selector switch. Adjusting oscillator slugs with this type tuner usually requires less work than with turret tuners where the switch points are stationary and coils revolve around the stationary contacts. Selector switch tuners usually have a small separate air capacitor for "fine tuning" adjustment.

TV tuners, regardless of type, are usually in the front right corner of the chassis. The tuners are a complete unit in themselves and the variable inductor type is mounted in a metal housing above the chassis. The other three types of tuners are set in a flush opening under the chassis.

Sets with turret or selector switch tuners often supply poor sound and pictures only because the oscillator adjust-

ment slipped while the TV set was in transit. A slight rotation of this screw may spoil either picture or sound, depending upon which way the screw drifted. This simple tuner adjustment surpasses the finest booster used on a set whose owner is not aware of the real cause for the poor signal on certain stations.

To adjust the oscillator coil, pull off the spring-loaded channel selector knob and fine-tuning knob. The metal or plastic channel plate is secured to the cabinet with a large hairpin spring in most instances. The plate may be shifted to the right to gain access to the oscillator slug, or the plate may be removed by compressing the hairpin spring from the two slots inside the opening in the channel plate.

Peeking into the channel selector hole in the cabinet, you will see a 1/4 in. hole in the turret tuner frame with a large brass screw behind it. Turn the fine-tuning vane if this hole is obscured. Then, with set tuned to a given station, insert an all-plastic screwdriver blade in the hole and turn the screw a trifle left or right. If your set is a separate sound I.F. circuit, adjust the screw for best sound. If your set is an intercarrier circuit, adjust screw for best picture (and minimum or no buzz in the sound). Grinding an edge on a plastic crochet needle (6 for 15c in dime store) makes an excellent adjusting screwdriver. *Never use a metal-blade screwdriver!*

Do not turn the slug screws more than one revolution in either direction, because the slug may drop into the chassis. The adjusting slug works on a single thread spring-tension feed. If the slug should fall into the tuner, you must remove the chassis from its cabinet and dismantle the tuner in order to replace slug. Replace large knob on turret tuner and turn to next station. Again insert the plastic blade screwdriver into the $\frac{1}{4}$ in. hole and adjust remaining channels in your area for best picture and clear sound.

If your set has the earlier selector switch tuner, two ()-shaped openings, revealing all 12 slugs, will be noted on the tuner box making slug adjustment simpler than on turret types. In both cases, a penlite is a useful tool for peeking into the cabinet hole.

Variable inductor and variable capacitance tuners require no pre-determined and precise tuning, because they are hand-tuned like a radio set. Variable tuners also cover the FM radio band while turrets do not. However, if your set is the separate sound, turret tuned type and there is no local station on channel 6, you can receive FM. Adjust the channel 6 slug until the best FM station in your locality comes in. Additional FM stations (but not all) will come in by using the fine tuning control as the FM station selector. Turn the brightness control on TV set to far left when listening to FM only. FM can be received in the same manner on intercarrier sets, but the quality may be poor and the stations jumbled.

TV Power Supplies. During the early TV boom, dozens of manufacturers turned out 7 in. sets with so-called *ac-dc* power supplies. These sets, like small *ac-dc* radios, employ no power step-up/step-down transformers, except for a special oscillator-generated source of low-current, H.V. which is applied to picture tube's 2nd anode.

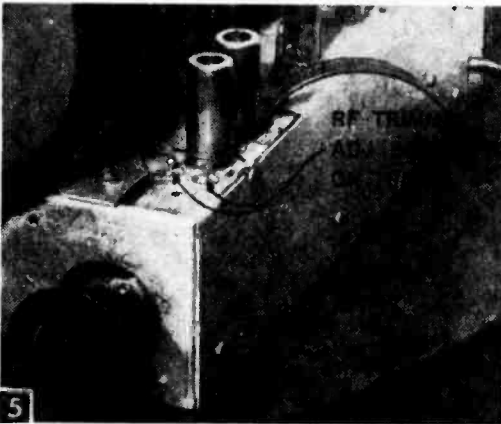

Minute adjustment of 0.5 to 3 mmf. R.F. grid and plate trimmers' screws may have marked effect on weak channel #7 to #13 stations. Mark position of screw slots on chassis so the trimmers may be returned to original settings if no picture improvement is noted. Do not confuse these minor adjustments with oscillator slug adjustments in Fig. 2.

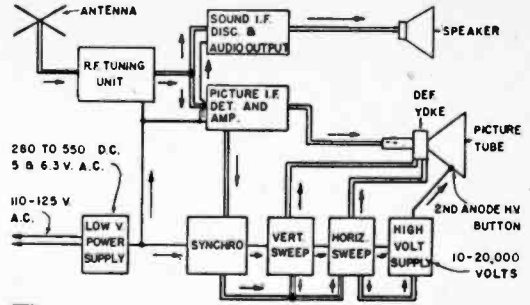

A SEPARATE SOUND I.F. TV SYSTEM

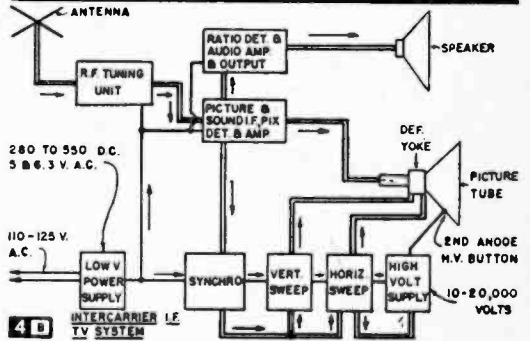

B INTERCARRIER I.F. TV SYSTEM

Another differing feature of these *ac-dc* sets from most TV sets is their lack of any gadgets around the neck of the picture tube. The *ac-dc* set employed an electrostatic focus-deflection picture tube which required no deflection yoke, focus coil or ion trap.

In trouble shooting such sets disregard any reference in our guide to the yoke, focus coil or ion trap. Locating a burned-out tube in an *ac-dc* TV set is a real job because tubes are grouped and wired in series like Christmas tree bulbs. When you have 16 or more TV tubes, and one tube in each string is out, a little luck helps.

You can easily identify *ac-dc* sets because there is no large black or silver painted power transformer in the rear-left corner of the chassis. An *ac-dc* set is also identified if 3 or 4 other tubes go out when you remove one tube from the chassis. Best method for locating the burned out tube is with a NE-2 glow tube tester which lights when touched across the filaments of the open tube. Removal of one tube from certain *ac-dc* sets may instantly burn out another tube working in parallel with it. These *ac-dc* sets are good only if you live in a *dc* district.

Most TV failures are merely defective tubes and a look into the set will reveal which tube requires replacing. Burned out metal tubes may be detected by touch—if it's cold, it's burned out. Do not, however, take a firm grip on a metal tube—some get as hot as a small soldering iron in normal operation.

TV sets that don't respond to simple tube replacement will usually come to life by applying the remedy suggested in the following table for the particular symptom.

T.V. Trouble-Tracing Guide

(Photos courtesy of Radio Corporation of America, Pict-O-Guide by John Meagher and Howard W. Sams Co.)

TV screen dark, no picture, no sound.

If tubes in set are lit, look for bad low-voltage rectifier(s). Chery glow on tube plates indicates short-circuit; usually a bad electrolytic condenser. If tubes are out, check outlet or set's line fuse (if any) for absence of 115 v. If lit, check for loose speaker plug.

TV screen dark, no picture, sound okay.

Check H.V. rectifier, damper, horizontal oscillator, and horizontal output tubes for a burn-out or a neon-like glow. These in or near H.V. cage. Also check 1/4 amp. fuse located in damper circuit, and look for disconnected H.V. cable to button on side of picture tube (2nd anode.) Check ion trap magnet on neck of picture tube. Picture tube won't light if trap is out of position.

TV screen lit, no picture, no sound.

Broken or disconnected antenna lead-in. Defective tube(s) in R.F. tuner, or in I.F. amplifier stages.

TV screen lit, no picture, sound okay.

Look for defective tube(s) in video amplifier, detector or video output stages. If set works on some stations, remove station selector knob and adjust oscillator slugs in turret tuner with plastic screwdriver. Adjust for best picture if intercarrier circuit—best sound for sets with separate sound and video I.F.'s.

tube, horizontal output and the damper tube. Width control may be out of adjustment or shorted.



Narrow picture. Screen dark on each side.

Check for defective low-voltage rectifier tube, or horizontal oscillator tube. Also check for improperly adjusted width control. Horizontal coil in deflection yoke may be defective. Check with neon lamp continuity tester.

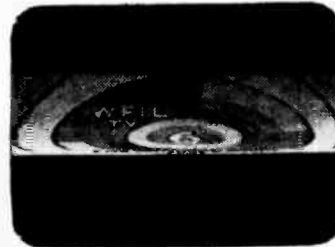

Squat picture. Screen dark top and bottom.

Vertical size control out of adjustment, vertical coil in deflection yoke may be defective. Check and replace, if necessary, vertical sweep oscillator or amplifier tube, or both defective.

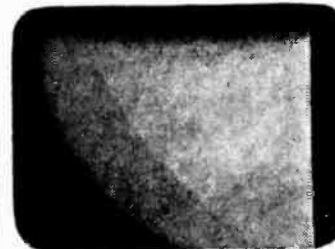

Picture not centered on screen.

Horizontal and vertical centering or positioning controls require adjustment. If set lacks these controls, center pix by adjusting the doughnut-like focus coil on neck of picture tube, or aluminum slip ring on deflection yoke. Then readjust the set's focus control, also ion trap magnet.

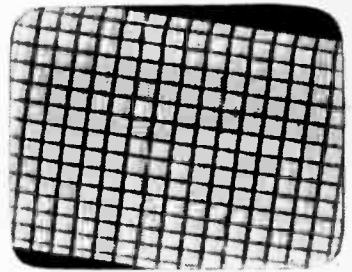

Picture tilted on screen.

Loosen wing-screw on deflection yoke and rotate coil right or left until pix is straight. Keep yoke against picture tube or "neck shadows" may result. Retighten wing-screw.



Corner(s) of picture dark.

Usually due to yoke not being against vortex of picture tube. Also focus coil and ion trap on picture tube neck incorrectly positioned will produce this condition. Readjust.

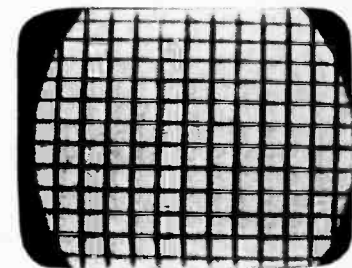

Picture too small. Screen dark around outside.

Check the low voltage rectifier tube. Deflection coil may be loose and not up against vortex of picture tube. If small pix is extremely bright, tube is receiving excessively high voltage. Check all tubes in H.V. cage and look for defective damper resistor (large porcelain resistor located near damper tube.)

Partial picture. Top or bottom of screen dark; part of picture compressed or folded over.

Adjust vertical height and vertical linearity controls. If condition persists, look

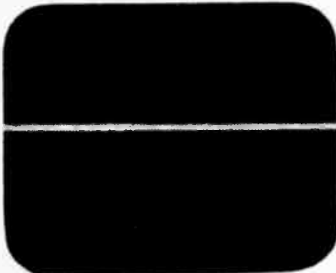

TV screen dark except for horizontal white line thru center of screen.

Defective vertical sweep oscillator or amplifier tube, or both. Vertical height or size control improperly adjusted.

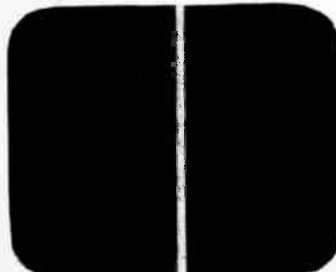

TV screen dark except for vertical white line thru center of screen.

Horizontal sweep circuit not functioning. Check horizontal oscillator and discharge

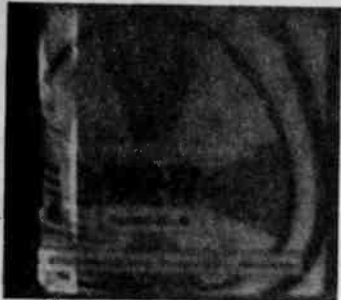

for defective vertical sweep oscillator or amplifier tube.

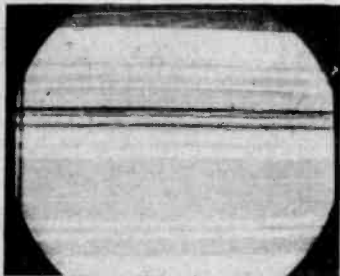

Wide dark bars running across picture.

A defective tube in video I.F., detector or output stages. Tapping tubes with pencil may reveal offender. Adjust sound discriminator screw. Check for defective contrast control.

Thin horizontal lines across picture.

Make same tube checks as for wide, dark bars. Also check tubes in the R.F. tuner section by gently tapping, wiggling or replacement if condition persists.

Vertical "running water" streak down left side of picture.

Barkhausen-Kurz oscillations induced within horizontal output tube (6BG6-G or 6BQ6-G.) Corrected by attaching a "Barkhausen Effect" magnetic suppressor to tube, or replacing tube if set has a built-in magnet attached to H.V. cover as in DuMont and some other sets. If trouble persists, replace damper tube.



Vertical wiggling lines through picture.

Often caused by a defective horizontal oscillator tube. If new tube does not help, try a wave trap on antenna lead-in as trouble may be a combination of a weak station and H.F. interference.

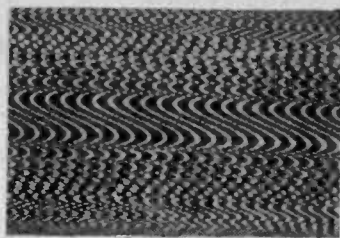

Vertical harsh S-shaped lines through picture.

Caused by either interference arriving at set with TV signal: X-ray, H.F. welders, FM stations, ham transmitters, etc. If wave traps will not remedy this condition, your set may be changed to work on modern 44 mc. intermediate frequency. Hire an expert serviceman to do this as special knowledge and precise instruments are required.



Zig-Zag horizontal lines through picture.

Adjust screw on automatic frequency control (AFC), centering and locking-in picture. Horizontal control knob on front of set may cause this condition if "off center", or control itself may be "shot." Most likely, however, condition will clear up by inserting a new horizontal oscillator tube in set.



Stacked pictures, rolling up or down on screen.

Vertical "hold" or "lock" out-of-adjustment; turn until picture holds. If rolling can't be checked, look for defective vertical sweep oscillator or amplifier tube or both.

Torn picture; or the decapitated body.

Again the horizontal oscillator tube may be the culprit. First, however, be sure the horizontal hold, automatic frequency or automatic gain controls are correctly set.

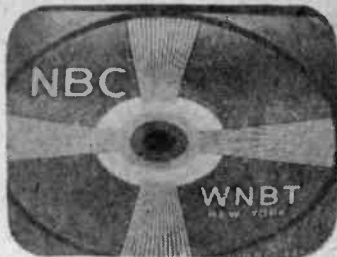

Squashed pictures (vertically).

Horizontal drive or horizontal linearity control not adjusted in step with width control. Adjust both controls only when a test pattern is on screen to insure getting image symmetrical. If trouble persists, check horizontal oscillator tube, horizontal output tube and damper tube.

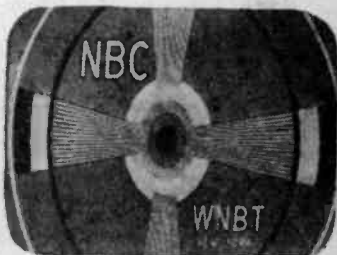

Squashed pictures (horizontally).

Vertical peaking-linearity control must be adjusted in step with vertical size control. Readjust both to correct condition, using test pattern to insure symmetry. If trouble persists, check vertical sweep oscillator and amplifier tubes.

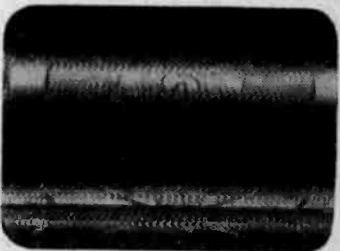

Severe "fishbone" pattern across picture.

Man-made interference frequently caused prior to June, 1952, by physicians' diathermy apparatus. Also by some X-ray, H.F. and resistance welding apparatus, electric furnaces, etc. Now outlawed by FCC, but old sets require new I.F. adjustment to prevent interference from this apparatus which is now working on FCC designated frequencies. If new I.F. adjustment is not perfect cure, insert suitable wave-trap in antenna lead-in. Use power line filter for welders, motors.

Picture lacks brightness.

Ion trap has slipped from its correct position on neck of tube. Rotate and slide forward and back on tube neck until a bright, shadowless picture appears on screen. Magnet may have lost charge; replace! Also check for defective horizontal output or high-voltage rectifier tube in H.V. cage.



Weak snowy picture.

Usually this condition exists in the R.F. tuner section. Oscillator slug for a particular channel may have worked itself out of adjustment. Adjust with plastic screwdriver until picture is clear and bright. Check all tuner tubes, and look for loose or broken antenna wires if slug adjustment fails to correct snowy picture. Video I.F., detector and output tubes or dirty turret tuner contacts may be source of trouble.

Blurred, indistinct picture.

Focus control out of adjustment, or (in some cases) shorted or burned out. Defective rectifier tube in low voltage circuit, or a shorted focus coil will prevent sharp focus. Also check for defective electrolytic capacitor(s) in low voltage filter.

Pictures jump.

Look for a loose connection on sockets of vertical sweep oscillator or amplifier tubes. Test tubes for possible internal defects. Check vertical hold control for a defective resistance element and replace if necessary.



Picture blooms, or expands and contracts in size.

Check H.V. compartment visually for signs of purple arcing on cable to side of picture tube, or anywhere inside H.V. cage. Disconnect power and brush out all dust. Also check the 1 meg. 1/2 meg. or 1/4 meg. H.V. filter resistor. Check horizontal output tube, damper resistor, damper tube, H.V. rectifier, and horizontal oscillator tube—all in or near H.V. cage.

Picture blooms when brightness control is advanced.

Similar to above, but usually corrected when H.V. rectifier or horizontal output tube is replaced.

White and black streaks on picture.

Sewing machine, vacuum cleaner, hand-grinder and similar high-speed brush motors. Also caused by H.V. leakage explained under "blooming" pictures.

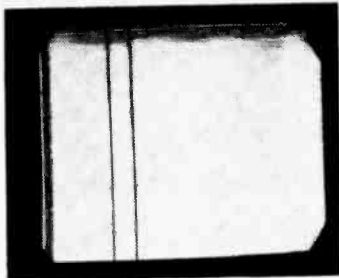

Picture good, but no sound.

If set is known as "intercarrier" type, the presence of a good picture indicates the tuner, I.F. stages, high and low voltage supplies are okay. The trouble is in the 4 or 5 tubes in the sound section of circuit. A defective ratio detector driver, ratio detector, audio amplifier, or audio output tube is most likely the cause. If set is a "separate sound I.F. receiver", it will be necessary to check tubes in these stages as well as those indicated above.

Picture good to fair. Loud hum or buzz in sound.

If set is "intercarrier" type, adjust screw on primary of ratio detector transformer for maximum sound on a weak station. Now tune set to a strong station and adjust secondary slug screw on ratio detector transformer until buzz is either eliminated or minimized. If set is "separate sound", merely turn screw on discriminator to left or right until all hum or buzz vanishes. (See special notes on Tuner Adjustment.)

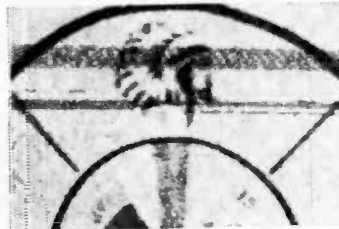

Keep H.V. cable to pix tube away from metal; remove dust from H.V. cage. Insert line filter if streaks caused by motors.

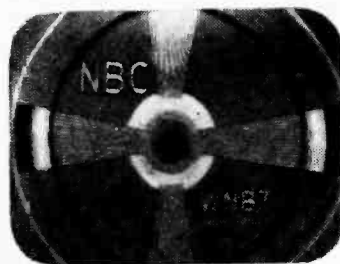

Picture good to fair, loud or medium hum in sound. No buzz.

Usually due to a defective electrolytic filter section(s) in low voltage power supply. Try a 40 mfd., 450 v. tubular electrolytic across each section of the can-type capacitors. Once defective section is located, just solder the unit permanently to the proper can lugs. If hum is intermittent and flashes appear on the picture screen, it is likely that an electrolytic section is in process of shorting. Watch the low voltage rectifier tubes for sign of plates glowing a deep red, or neon-like glow around plates. Disconnect set at once to prevent further damage. Check sections of capacitors for the short. Clip this section out of circuit entirely and insert a single tubular replacement section of suitable capacity and working voltage.

On "intercarrier" sets, hum or buzz is often due to "contrast" control being turned too far to right. This is no sign of a circuit defect if the hum or buzz is eliminated when contrast is retarded.

Picture good, but sound hollow, distorted, or has ringing background.

Microphonic, or gassy tubes in audio section of set. Check and replace suspicious tubes. Also look for defective electrolytic capacitor in the cathode circuit of audio output, and paper coupling capacitor between audio amplifier and audio output tubes.

—O—

The above guide should cover up to 80 percent of all TV set failures. If your trouble differs from the symptoms listed, or is not remedied by the suggestions given, do not tinker with the set! Some TV repairs require apparatus and skill beyond that possessed by the experimenter. Call in an expert repairman!

Shadow Images.

Known as ghosts, these weaker signals are bounced off buildings and reach your set just behind the fundamental picture signals. Sometimes relocating the antenna will correct this condition if reflections are local. However, reflections may originate near the TV transmitter and there is no cure unless TV station moves to a new location. And this has happened in several instances.

Smallpox and liver spots.

Speckled screens, and permanent brown or yellow spot in center of screen calls for a new picture tube. If screen is speckled, the fluorescent coating has flaked due to age or poor manufacture. A brown spot is due to ion trap not being adjusted to give brightest picture, or set turned on without ion trap attached to neck of picture tube. Always keep brightness control at a very dim position when adjusting an ion trap. Turn up only after image is visible on screen.

All component parts and tubes technically described in this column are clearly shown and identified in both Sams and Rider data available for your set. Their data is not of a "how-to-fix" nature which is the purpose of this Trouble Guide when used in conjunction with basic information covering your specific set.

How to Get Three Speeds from a Two Speed PHONO MOTOR

By ARTHUR TRAUFFER

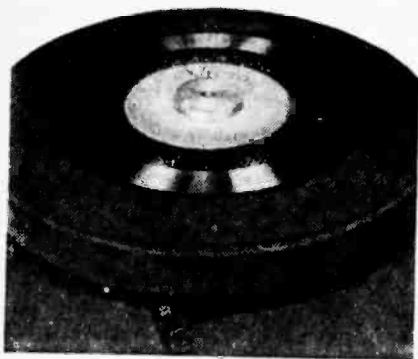

Fig. 1. The centering disc for Victor 45 rpm records. The writer turned his disc from cold-rolled steel.

IF YOU own a General Industries Model-DR dual-speed (78 and 33 rpm) phono motor which plays both standard discs and Columbia LP's, you can, by a simple operation, convert it to play in addition the new 45 rpm RCA-Victor discs. An inspection of the motor (Dwg. 1) reveals that the 78 rpm part of the motor shaft is a removable aluminum collar held by a spline type set-screw. When set-screw is loosened and collar removed you will find the motor shaft measures about .3115 in. and gives turntable a speed of about 58 rpm. Pack cotton around motor shaft to keep metal shavings out of motor bearings, and while motor is running, file shaft down to about .263 in. or just enough to give exactly 45 rpm. (Dwg. 2). Now the table speed can be shifted from 45 to 33 rpm instead of from 78 to 33 as formerly and the aluminum collar can be put back



Fig. 2. The works of the General Industries Model-DR dual-speed phono motor. Pencil points to the 78 rpm diameter on removable aluminum collar over motor shaft.

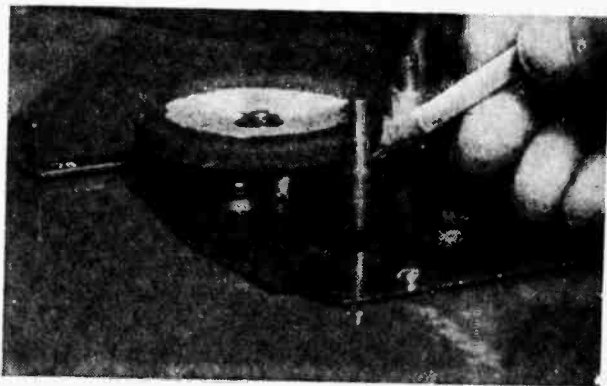

Fig. 3. The 78 rpm aluminum collar has been removed by loosening spline set-screw. Pencil points to part of motor shaft that has been filed down to .263 in. or just enough to give exactly 45 rpm. Aluminum collar can be put back for 78 rpm.

on the motor shaft to play 78 rpm discs.

Use a new or clean file to file shaft to 45 rpm. The motor shaft turns in a counter clockwise direction; move the file against the direction of turn. Take a little at a time off the shaft and test for speed each time to prevent obtaining a turntable speed below 45 rpm. Turn centering disc on a lathe from cold-rolled steel, fiber, plastic, or even hardwood (Dwg. 3).

The Super Brake

A small electric motor, spinning 16,000 times a minute, is halted in six turns by a new magnetic brake—equivalent to stopping a mile-a-minute automobile in 2.73 feet.

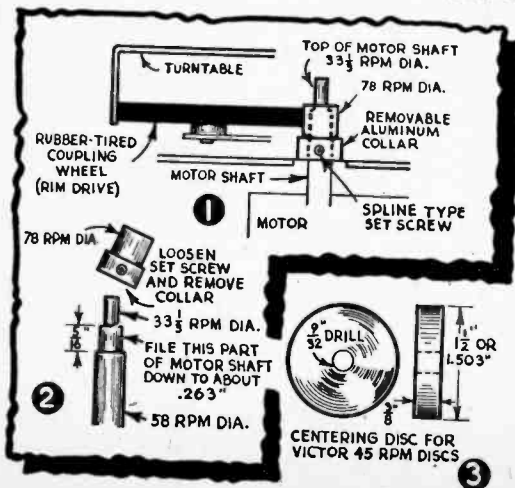

Supercharge Your Small Radio

Battery and electric portable and table sets become "hotter than a \$2 pistol" when you replace the old built-in loop with this new Ferrite tuned R. F. coil!

By THOMAS A. BLANCHARD

PERHAPS you have a small table or portable type superhet radio operating on a built-in loop antenna which must be turned in a certain direction to give satisfactory reception. With a coil called the *Ferri-Loopstick*, the set will not only work equally well in any position, but can be made to pull-in stations never picked up before. This coil, no larger than a cigaret, replaces the original loop antenna and increases your set's sensitivity up to 250%. Radio supply houses should be able to supply the Grayburne "Ferri-Loopstick" which forms the heart of this conversion for about \$1. If you have trouble finding one, you may obtain one from E. G. Little, Mfrs., Springdale 1, Conn.

For a fixed installation (Fig. 2), remove from your set the fiber or Masonite back to which the old loop is attached. Disconnect the 2 wires



Fig. 1. Long-distance stations come in with amazing power with DX Tuner. Whip-antenna is a piece of coathanger wire about 16 in. long.

leading from the set to the loop, using a soldering iron if necessary. (You'll find the wire to the inner lug of the old loop is usually green; the outer loop lead is black or yellow if set also has shortwave coverage). Drill a 1/8 in. hole in the Masonite back and mount the ferri-loop by means

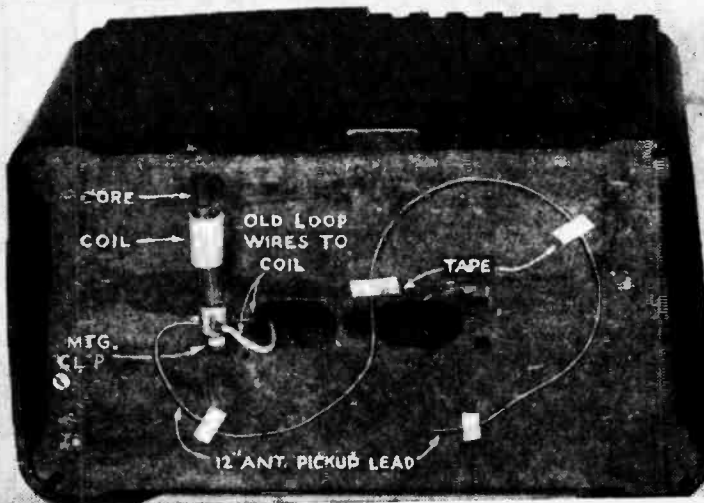

Fig. 2. Ferri-loop "fixed" installation. For detail, panel is shown with coil and pick-up lead exposed. Turn Masonite panel so components are inside, facing chassis.

ORIGINAL RADIO LOOP ANT. DISCONNECT AND ATTACH TO GROUND LUG ON FERRI-LOOP OUTER LUG



GREEN DISCONNECT & ATTACH TO ANT. LUG ON FERRI-LOOP
(GRID) ↑
BLACK OR YELLOW (GROUND)
TO SET'S 365 MMF 1/4 x 1/8" HOLLOW SECTION OF TUNING FERRITE CORE CONDENSER

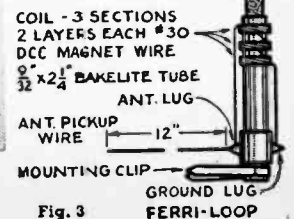

Fig. 3 FERRI-LOOP

of the clip provided (Fig. 4). Unwind the 12 in. length of #28 enameled magnet wire soldered to antenna lug of ferri-loop coil, and form in "S" shape. Attach to Masonite with pressure adhesive tape. Solder green lead from set to lug with 12 in. antenna pick-up wire; connect black lead to remaining lug on ferri-loop. The set is now ready for test and signal adjustment.

Tune your radio to a station as close as possible to 1000 KC (shown as 100 on dials of most sets). Now move the adjustable ferrite core in and out of coil form until station comes in at peak volume. The core is slightly warped in process of manufacture so that it maintains a friction fit inside coil. In making ferrite core adjustment, don't use your fingers, because of body capacitance effect on coil. The core has a $\frac{1}{16}$ in. hole through its length so that a wooden matchstick may be used to position it for optimum tuning over the entire Standard AM band. When correctly positioned, apply Duco or similar cement to ferrite core and coil form so ferri-loop remains permanently fixed. For even greater range, attach up to 6 ft. of loose wire to antenna lug of ferri-loop.

If your set does not "track" properly over entire broadcast band, adjust ferrite core so stations are received properly from 550 to 1000 KC on dial. Cement core as previously described, and adjust RF trimmer screw of 365 mmf. tuning condenser for maximum volume with set tuned to the 1500 to 1000 KC stations. Use plastic blade screwdriver.

For those who love to spend half the night listening to faraway stations, we have designed a "DX" long-distance tuning control which will extract the last grain of energy out of the ether and pump it into your set (Fig. 1). The ferri-loop is identical to the one used in the "fixed" installation, but a $\frac{1}{16}$ in. dia. $1 \times \frac{1}{4}$ in. long plastic or wooden rod is gently forced into ferrite core (Fig. 4). Fit remaining end of rod to an applicator type Bakelite bottle top, although this knob is solely for appearance.

Drill a $\frac{3}{32}$ in. hole in end of 3x2x1 in. plastic box which contains ferri-loop and connecting

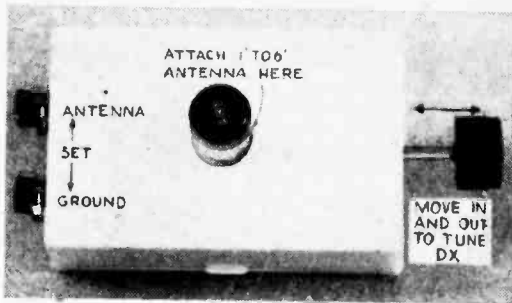

Fig. 5. Close up view of DX Tuner. Small plastic boxes may be found in most variety stores.

terminals to provide a pressure fit for ferri-loop coil form. If hole comes out a trifle oversize, a dab of Duco cement will anchor coil. Two clip connectors are provided in opposite end of box, while an antenna binding post is mounted on top of plastic box for attaching either a whip-type antenna or a flexible cord. Make whip antenna from a length of coathanger wire with a $\frac{1}{2}$ in. right-angle bend on one end. Insert this end into the X-L binding post marked "Ant." Connect leads from vacated set loop antenna to clips. Tune set to a desired frequency and push ferrite plunger rod in and out until the ferri-loop is tuned to exact frequency of station desired. The results are amazing!

When using the DX model, the plunger will be all the way in for stations near 550 KC, and way out for stations around 1500 KC. Plunger will peak the set at intermediate positions as you tune around dial.

Some 4- and 5-tube table model superhets may use an internal R. F. transformer and a hank of flexible wire instead of a loop. Equip such sets with a ferri-loop by installing latter in place of the original coil to which the hank of wire terminates. Make ferri-loop connection to secondary connection points of old R. F. transformer (green and black leads).

While most sets will have but 2 wires from the chassis to the old loop, a few deluxe sets as well as those with shortwave bands, will have 3

or 4 wires. The extra wires are frequently connections for the external antenna. These leads will be the extreme outside connections on loop and need not be disturbed. Some sets may have an external antenna terminal connected through a small mica capacitor to the inner loop lug (usually green). If you need an outside antenna on some occasions, solder it to the antenna lug of the ferri-loop. Otherwise, leave the mica capacitor disconnected.

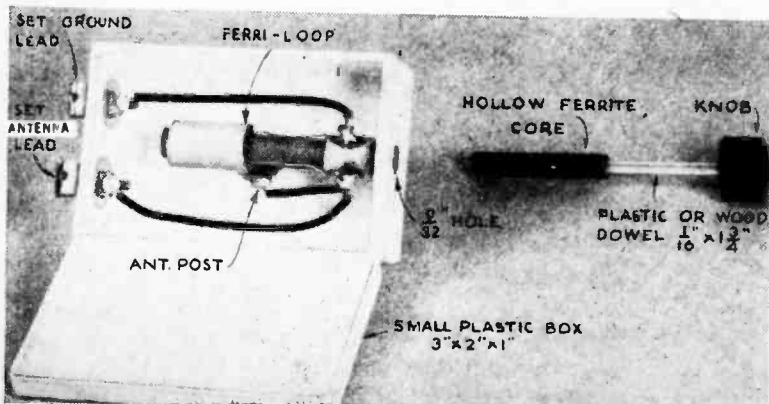
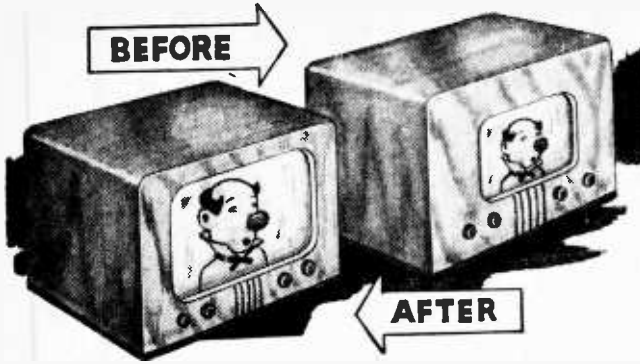

Fig. 4. Picturegraph of DX Tuner. Components and wiring used for this unit are clearly shown here.



basically the same. This is the *horizontal output* and H.V. (*high voltage*) circuit, housed in a shielded safety box. This box occupies the left-rear corner of the chassis when set is viewed from the front. Cover and sides of this box are secured with 5 or 6 sheet metal screws. The power cord with an interlock connector disconnects when this cover is removed. There is, therefore, no danger of shock, for the set cannot be operated until this cover is replaced.

Converting Your Small-Screen Set to a 16 in. TV Receiver

Don't discard that old set—it may be better than some new ones if you switch to a full-vision 16 in. picture. You can easily make these simple alterations for under \$50!

By THOMAS A. BLANCHARD

WITH government limitations on civilian use of critical materials, TV manufacturers may not be able to produce sets equal to those produced in the past. If you own an old—but good—small-screen set, you can easily convert it to a modern, rectangular 16 or 17 in. job. The end result may be a lot superior to something you might buy during the coming months. You need no previous radio experience to modernize your old set if you study the accompanying diagrams carefully and then take your time making the alterations.

Of all TV sets in use today, the greatest number are still based on the original RCA 630's design. Although a number of electronic improvements have been made, the portion of the circuit we are interested in remains

For a number of receivers, conversion to the large rectangular 16RP4 picture tube can be accomplished in an hour (not including cabinet revisions). If you now own a 12 or 12½ in. set (and some 10 in. models) you will need in addition to the picture tube only 2 new components: a 70° deflection yoke and a mica trimmer condenser with a capacity range of 200 to 600 *mmfd*. Old 10 in. sets will require the yoke, plus a new ferrite H.V.-output transformer.

But let's take the conversion in several easy steps. First remove bolts which secure chassis in cabinet. Disconnect speaker plug or remove speaker from cabinet. Remove Masonite back from cabinet (if any) and then pull off control knobs, which are spring-friction held (except for certain Du Mont knobs which have set-screws).

Next slide chassis out of cabinet. Remove ion trap (Photo B) after disconnecting socket from picture (kinescope) tube. Remove metal picture tube retaining strap. If picture tube is secured by woven strap, loosen clamps, slide strap off over face of old picture tube. Pull out H.V. snap

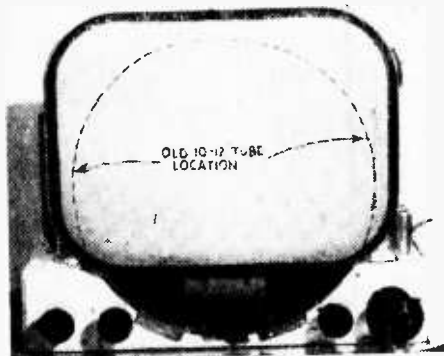

(A). New 16 in. rectangular 16RP4 tube spans cavity of old round tube area. Only $\frac{3}{5}$ of the face of old round tube is usable.

If, conversion has been completed without replacing the horizontal output transformer and the resulting picture is too narrow and lacks brightness, replace the horizontal output transformer with a new unit.

connector on kinescope and remove old tube from chassis. Handle old and new tubes with care. A dropped tool will possibly implode glass. While the reverse of an explosion—the flying glass is just as deadly. Use common sense in handling picture tube, do not handle by narrow neck.

Replace the original 53° deflection yoke with a new 70° type. Remove cardboard cover from old yoke and unsolder the two 560 ohm resistors and 50 (or 56) mmfd mica capacitor. The old yoke will have only 6 soldering lugs while the new yoke is likely to have 8 lugs. Replace capacitor and resistors in new yoke as shown in Fig. 3. If, however, the new yoke has the same 6 lug arrangement as the old 53° unit, replace components just as they were.

Disconnect width coil located in upper right corner of H.V. compartment. Its leads terminate on terminal lugs #5 and #6 of the H.V. and horizontal output transformer. Remove, also, the green wire from #5 and move it up to #6 lug. Next, connect top leaf of 200-600 mmfd trimmer to set chassis. Connect remaining trimmer lug to lug #4 (yellow lead) of H.V. transformer.

The original small picture tube rested in the circular cavity in front of chassis; the new tube will straddle this gap (Photo A). Remove one of

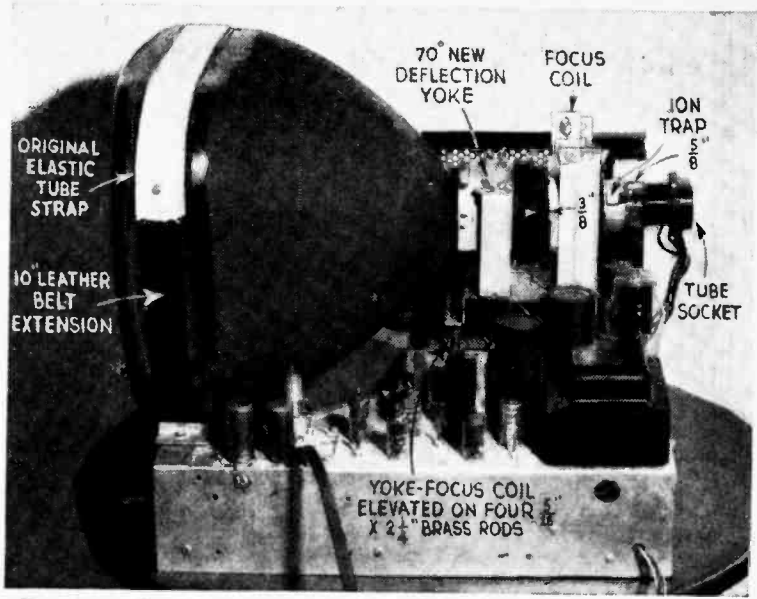
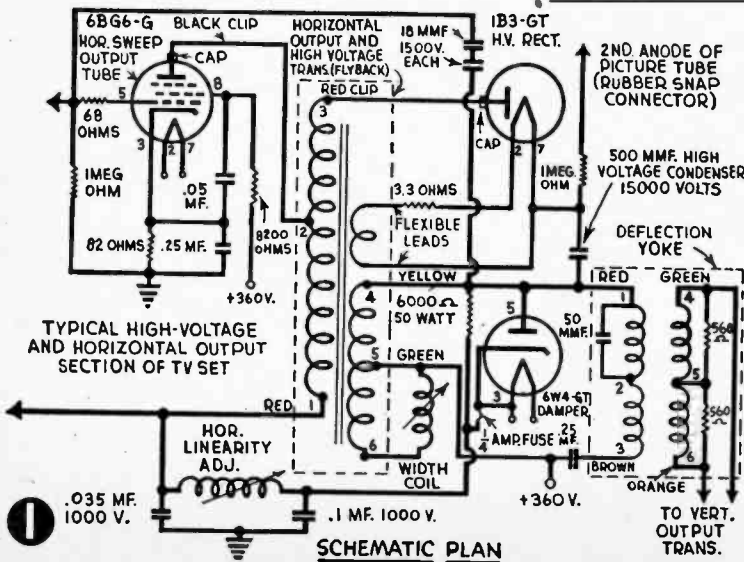

Photo B. Profile view of set converted to 16 in. picture. Note position of ion trap, about 3/8 in. from picture tube base. Focus coil is about 3/8 in. from deflection yoke. Note 10 in. leather belt extension on elastic picture tube strap.

MATERIALS LIST—TV CONVERSION

- 1—16RP4 Rectangular Kinescope Tube (any available brand)
- 1—70° Deflection Yoke, GE, Alpha, RCA, etc.
- *1—12-13KV Horiz. Out.-H.V. Trans. GE, Ram, Merit, etc.
- *2—15KV 500 mmfd H.V. Condenser. Jeffers, etc.
- 1—200-600 mmfd mica trimmer condenser. Automatic, etc.
- 1—16 in. Lucite Rect. Mask
- *Components not needed, except for early 10 in. sets and all others in very weak signal areas where additional brightness is required.



the rubber channel bumpers; cut in half and slip over edges of circular gap to provide a cushioned rest for the new rectangular tube. The original focus coil and deflection yoke bracket must now be elevated to accommodate the new tube. You don't have to buy new brackets for this. As seen in photos, the 4 sheet metal screws which held the bracket to TV chassis are removed. The yoke-focus coil unit is elevated on 4 pillars or spacers made from 5/16 in. brass curtain rod or gas-line tubing, 2 1/4 in. long. Four 2 1/2 in. long 8-32 machine screws pass through the

pillars and are secured with nuts under chassis. If your set is an early 10 in. model and focus coil and yoke are individually mounted to chassis, cut the pillars 3/4 in. long, and use 3/2 in mounting screws.

The original cloth strap will be too short to secure the picture tube to the chassis. We lengthened the belt with a 10 in. piece of leather trouser strap and joined the belts with a 3/8 in. flathead 6-32 machine screw and nut. Cover the screw head with a strip of adhesive tape to prevent its scratching the tube. Note that with a 12 in. set, you don't have to move the strap clamps, as they will also accommodate a 16 in. picture tube.

Now install new 16RP4 picture tube by sliding into yoke so yoke rests tightly against the kinescope tube. Pull strap up over face of tube to secure it to chassis. Replace ion trap. If old type tube used a single Alnico Magnet, you will have to obtain a trap with 2 magnets. Position trap with arrow toward focus coil and upward. Photo B shows approximate spacing of ion trap, focus and deflection coils on neck of picture tube.

Next replace H.V. compartment cover. Plug in set to power line, turn brightness control to far left and

set channel selector switch to best station. Advance brightness slightly so scene is barely visible. Rotate ion trap and/or move slightly back and forth on neck of picture tube for brightest image. Get brightest image possible with retarded brightness control until properly adjusted; otherwise damage can result in a brown spot burning on face of picture tube. Our photo shows approximately correct spacing for ion trap and focus coil.

If focus coil is not far enough forward toward yoke, "neck shadow" will result. This won't hurt tube and turning and elevating focus coil slightly on its bracket will eliminate this condition. To straighten out a tilted picture, loosen screw which secures the yoke, and turn yoke right or left as necessary. Keep yoke tight against vortex

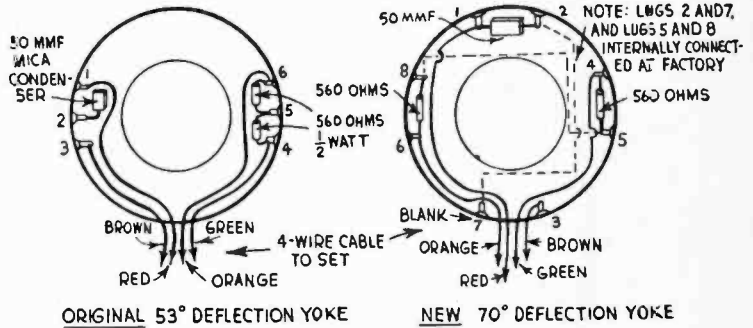

ORIGINAL 53° DEFLECTION YOKE NEW 70° DEFLECTION YOKE

2 PICTURE WIRING PLAN OF OLD AND NEW DEFLECTION YOKES AS SEEN WITH CARDBOARD COVER REMOVED 3

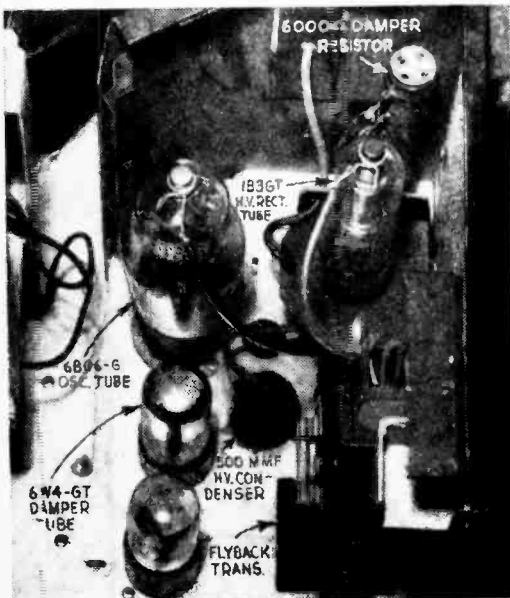

Photo C. Close-up of H.V. section. If set needs new H.V. "flyback" transformer, disconnect one wire from damper resistor. Replace original 500 mmfd condenser with new unit rated 15,000 volts. Many sets need only a trimmer attached to H.V. transformer as shown in Fig. 5.

of kinescope or picture tube.

Compressing the trimmer screw will provide ample sweep for the new 16 in. kinescope when conversion is from a 12 or 12 1/2 in. set. If picture overflows, loosen trimmer screw with a plastic blade screwdriver or one whittled from a wood dowel. Adjust height control on set to fill screen. If TV test pattern is distorted also adjust the vertical linearity adjustment screw. Finally reset focus screw as any change in position of focus coil requires readjustment of this control as well.

How About 10-In. Tubes?

Some 10 in. sets do not deliver ample high voltage to the 2nd anode of kinescope tube for daylight reception when set has been converted to 16 in. size. In such instances, the horizontal output and H.V. transformer (flyback and kickback are its more familiar names) must be replaced. Heretofore, it was necessary to use a voltage doubler circuit which used two 1B3-GT rectifiers and an additional filament wiring on the H.V. transformer, for handling the extra tube. But the new Ferrite core transformer introduced by General Electric makes an extra rectifier tube unnecessary. Moreover, this new high-Q transformer weighs only about 1/2 as much as the lower voltage unit it replaces. When picture brilliancy is so low that the extra 2nd anode voltage is necessary, several internal circuit

changes must be made.

The 500 mmfd "pillbox" high voltage condenser rated at 7,000 to 8,000 volts must be replaced with one rated at 15,000 volts. Also the two 18 mmfd series capacitors between plate of damper tube (6W4-GT) and horizontal output grid (6BG6-G) must have a higher breakdown rating from the old 1,500 v. to 2,500 v. The new units may have a capacity as low as 10 mmfd each.

The Ferrite transformer (Photo D) has an additional lug (#7) to which only the plate of 6W4-GT damper tube is connected. At the same time the 50-watt 6,000 ohm cathode-plate damper resistor must be disconnected at one end

(Photo C). Don't remove from chassis; just disconnect one side. All other leads which terminated on lug #4 of the "flyback" transformer go to the original plate junction of the 6W4 except for the 6W4 plate (Pin 5) as stated above.

Your converted chassis may well fit the old cabinet simply by enlarging the old oval picture opening to accommodate the new rectangular tube. Discard the old safety glass and escutcheon and saw out the cabinet front to suitable size. Several firms make Lucite masks which combine both safety lens and gold mask in a one-piece unit. No matter how poor a woodworker you may be, the enlarged opening in cabinet is given a trim appearance by attaching one of these Lucite masks with 4 to 6 rosette-head nails.

If the original cabinet doesn't quite clear the new 16RP4 kinescope tube, cut off the cabinet top. Set in a strip of 1/2 x 2 in. wide plywood on front and 2 sides, then glue and clamp. Paint inserted strips to match Lucite mask.

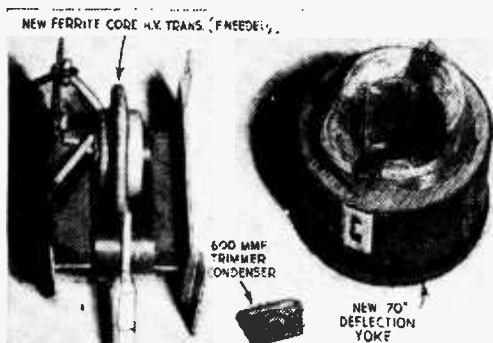
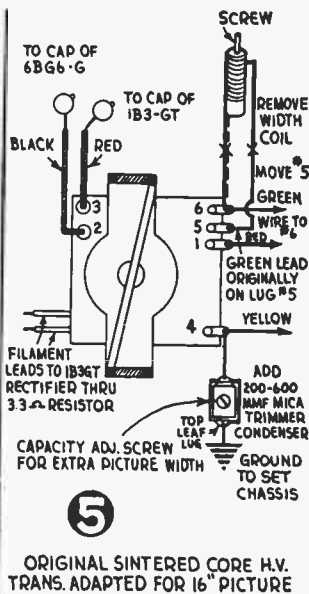
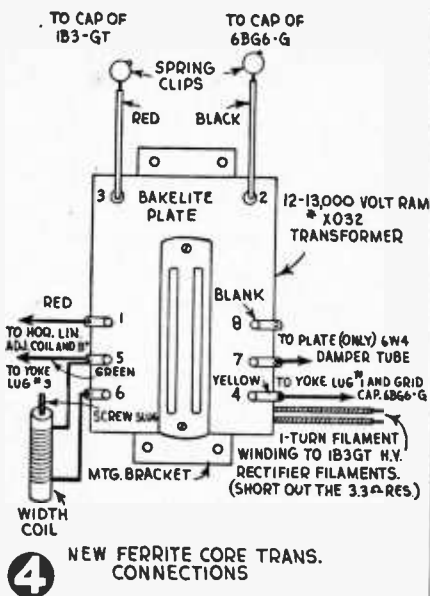

Photo D. New Ferrite core H.V. transformer replaces unit in early 10 in. sets. All sets (10, 12 or 12½ in.) must employ new 70° deflection yoke at right, but many sets can use old H.V. transformer with 600 mmfd trimmer width control installed as in Fig. 5.



Some early 10 in. sets employ a 5V4-G damper tube. Sets with this tube are apt to have a "flyback" transformer with lugs numbered differently than shown in Fig. 5. If width coil is found to be connected to lugs #2 and #3, it is the old type. In most instances this transformer will deliver no more than 7,000 volts. Replace it with the Ferrite transformer (Fig. 4). Some sets (Du Mont especially) have a 2- or 3-position tap switch built into the H.V. compartment. Switch has a screwdriver slotted shaft which, when turned, increases picture width to fill the 16 in. tube face. Sets so equipped need only have the deflection yoke replaced. The H.V. compartment is not touched internally.

For sets with picture mounted off-center on chassis, or certain components obstructing the larger tube's placement on chassis, you can purchase a set of Universal tube mounting brackets to elevate and support kinescope. Sets that have 7 and 8 in. picture tubes employ electrostatic deflection as do those very few that use a 10DP4 kinescope. Converting these sets to 16 in. is complex. All other 10 and 12 in. picture tubes employ electromagnetic deflection and the old kinescope socket is directly interchangeable with the new 16RP4. By and large, the old sets employ a 10BP4 or 12LP4 kinescope. The maker's number is not important so long as tube is not a 10DP4 or a 7 or 8 in. type.

A word of warning—the flexible cable and rubber-covered clip which snaps into side of kinescope tube carries up to 14,000 volts. Never turn on set if this 2nd anode lead is not connected. Don't ever disconnect it if TV set has power turned on. Note that our drawings indicate color of wires connected to terminal lugs on yoke and H.V. transformer. Should your color-coding not correspond with these, connect your leads in accordance to lug numbers.

BIG PICTURE TV. With Simplified High Voltage Hook-Up

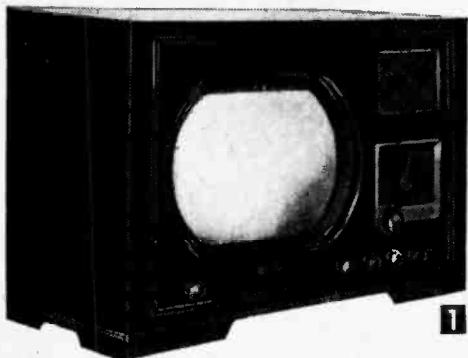

Above, here is the 12 in. tube Dumont set prior to its conversion to a 20 in. tube. Right, same Dumont set after conversion. Not only was the tube changed to 20 in., but the old table model teleset cabinet was discarded, and designer Leon Seaf built this new cabinet to house the converted set. Note that the cabinet is 55 in. high to provide unobstructed vision for all viewers. It is also 27 in. wide and 23 in. deep, and was made of $\frac{1}{4}$ in. walnut veneer plywood with 1-in. pine corner molding for trim.

IN THE preceding article we described two methods for converting a 10- or 12-in. round or oval TV set to a 16- or 17-in. rectangular large screen TV. Since then, we have thoroughly tested a new, simplified conversion method that rarely requires any complex circuit modifications under the chassis. The few soldering connections necessary are all conveniently located within the high voltage (H.V.) power compartment. Fig. 1 shows the *before* and *after* views of the conversion using this method.

To switch to a big tube the old H.V. transformer is removed and replaced with a unit delivering between 13- and 15,000 volts. However, many who follow the schematic wiring plan supplied by transformer manufacturers find that their set requires under-chassis wiring changes. Having made the necessary alterations, the TV fan may find that all he has for his work is a display of high-voltage fireworks (*corona discharge*) in and around the new H.V. transformer—and either no picture, or a small fuzzy image!

While the original, simplified method of conversion for increasing the sweep of the original small screen set to 16 or 17 in. rectangular size works well, there is a need for more brightness and contrast to the picture image in outlying areas. If you've already converted your set according to the previous plans, the small investment for the parts required here will be well repaid. Essentially, you need to

Small TV sets need no under-chassis re-wiring for converting to "life-size" pictures with this high voltage supply

By THOMAS A. BLANCHARD

Photos and Cabinet Design by Leon Seaf

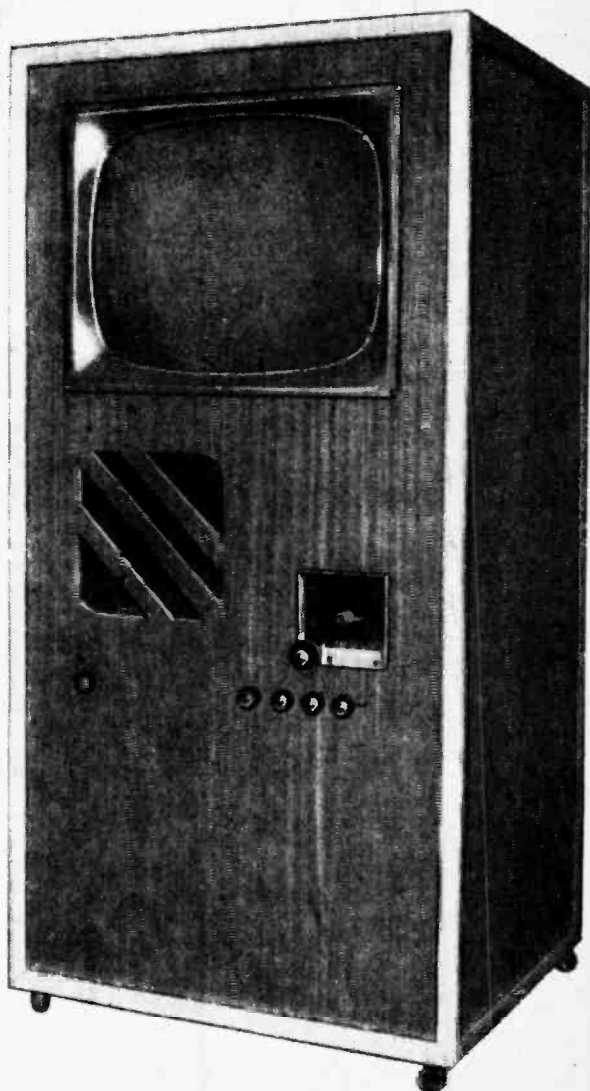

make the changes and substitutions shown as A, B and C in Fig. 2. And if you should wish to convert your TV set to a full-scene, big screen set, this system requires little or no technical knowledge.

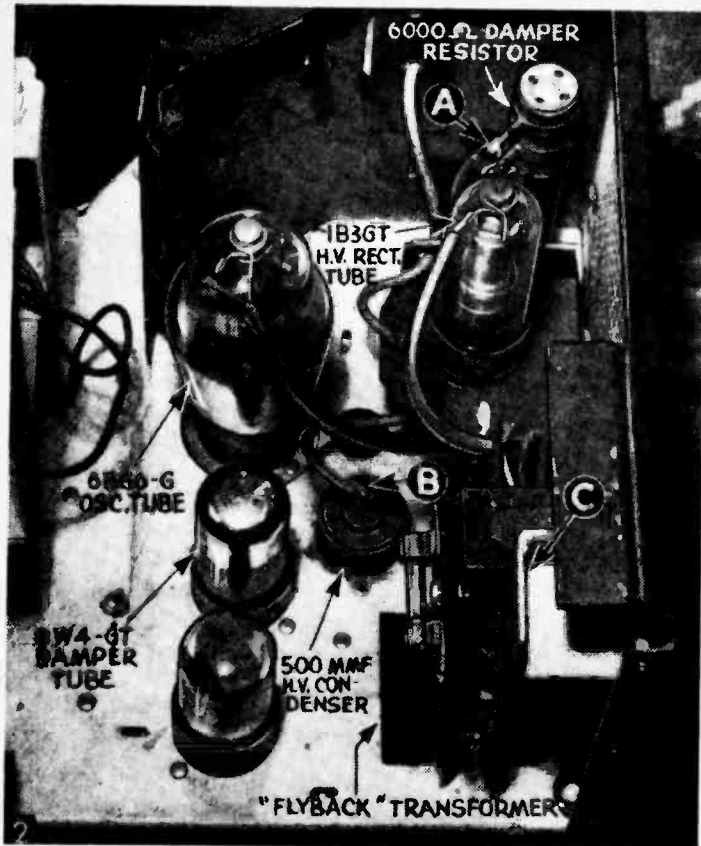

Remove the screws securing the cover of the high voltage compartment. The power cord on most sets has an inter-lock plug which disengages power when the cover to power unit is removed. In any event, be sure the power is off. Having on hand the components in the Materials List, begin the conversion by removing the old high voltage transformer, and the screw adjustment width coil directly above it. Before unsoldering the colored wires from the transformer, note the lug numbers engraved on Bakelite panel and color of wires connected to respective lugs. As each wire is removed, tag it with the proper number. Replace wires to like numbers found on the new transformer. Free the elevated socket mounting which supports the 1B3GT or 8016 high-voltage rectifier tube. Unsolder the two filament leads connecting from transformer to socket; connect leads of new transformer to the same points.

The new transformer (Fig. 3) mounts in the same place as the old one it replaces. Having soldered the flexible leads to the 1B3GT socket lugs; replace the elevated socket mounting and mount the new transformer to side of compartment. Now connect the colored leads (which you have tagged according to number) to the matching numbers on the new transformer. When all have been soldered in place, you will find

Original H.V. section as converted according to the preceding article. Additional changes required for improved performance are shown as A, B and C. (A) Disconnect this wire from damping resistor and insert 10 watt, 5000 ohm resistor in series with original resistor, (B) disconnect wire from top of original H.V. capacitor (condenser). Resolder to one end of new 15,000 volt, 500 mmf. Ground other end of condenser to set chassis, (C) remove and install new H.V. trans. in same mounting holes.

that lug #8 is a blank, and #6 and #7 aren't used in this hook-up (Fig. 3).

Next disconnect the wire soldered to the top of the original 500 mmf. H.V. filter capacitor (Fig. 2B). This wire is then soldered to one screw or pin of the new 500 mmf. 15,000 volt capacitor. The remaining pin or screw is secured to the set chassis. In many sets, the old H.V. capacitor connected internally to the plate of the damper tube; to remove it from the chassis is complicated and unnecessary. The H.V. capacitor in practically all new TV sets is grounded just as we have done here.

Next—and contrary to all

MATERIALS LIST—BIG SCREEN TV

- 1—Ram #X035 Horizontal Output H.V. Transformer (13-15 kV output).
- 1—500 mmf. H.V. Filter Capacitor (15-20 KV rating).
- 1—5,000 ohm, 10 watt IRC type AB Resistor; or 7,000 ohm, 25 watt adj. resistor (see text).
- 1—70° Deflection Yoke (not needed in some instances).
- 1—Single Magnet Ion Trap.
- 1—Choice: 16, 17 or 20 in. Rectangular Tube. (New tube plugs into same socket as old 10 or 12-in.).

data packed with the new H.V. transformer—do not eliminate the damping resistor! Instead, increase its resistance by disconnecting the wire soldered to its topmost lug. Now insert a 5000 ohm, 10 watt resistor in series with the original 5300 or 6000 ohm unit, bringing the new total damping resistance to about 11,000 ohms.

This completes the H.V. conversion, and the safety cover may now be replaced. Check to see that clip leads from transformer to the 1B3GT and 6BQ6G tube caps do not contact each other. Also keep the lead from the 1B3GT to the H.V. condenser from contacting the chassis. Likewise flex the two filament-cathode wires from socket to H.V. transformer so they are away from metallic chassis contact.

In changing over a 12-in. set to a big rectangular picture, no further circuit alterations are nec-

essary in many instances. Often the original deflection yoke works well. If, however, a circular shadow appears around the picture, the yoke should be replaced with a 70° type as explained in the preceding article. No under-chassis work is necessary here, either.

Having mounted the new picture tube, bring the yoke as close to the tube as it will go. Also move focus coil forward against yoke. The ion trap on the neck of the old small screen tube may have been fitted with two small Alnico magnet bars. Viewing the set from front, remove left-hand magnet, if feasible. Otherwise buy a new

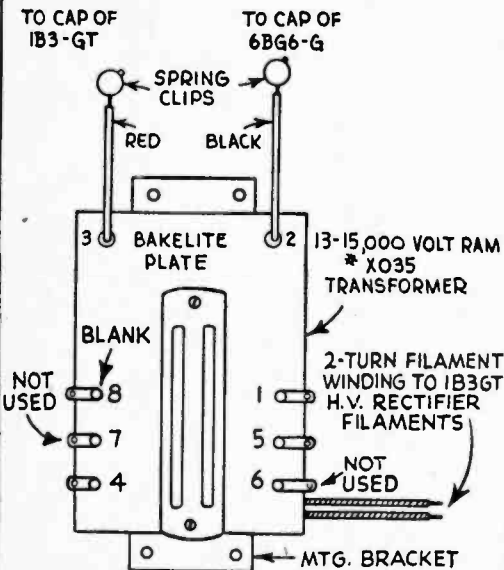
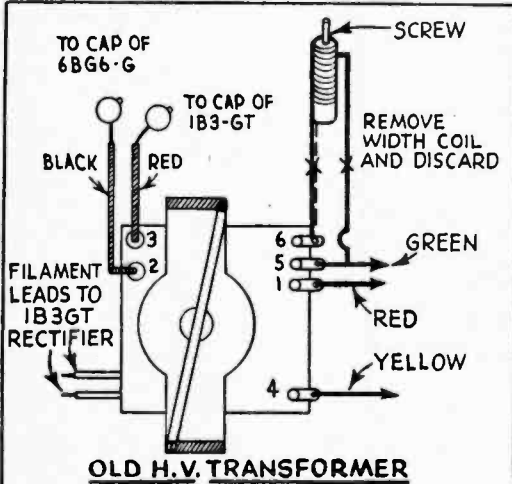

NEW FERRITE CORE H.V. TRANSFORMER
RAM #X035

MOUNTS IN SAME HOLES AS ORIGINAL. RE-CONNECT WIRES TO SAME LUG NUMBERS AS ON OLD TRANSFORMER.

3

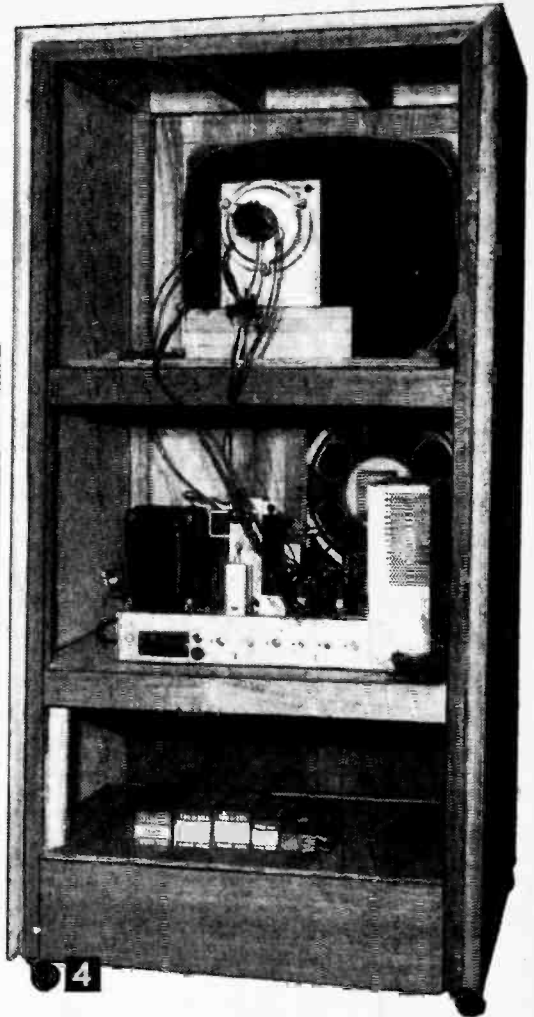

Rear view of converted 20 in. Dumont TV set. Space originally occupied by old small screen tube is now location of high-fidelity 12 in. PM speaker; replacing original 5 in. speaker. Yoke and focus coil bracket was removed from chassis and mounted on shelf in which 20 in. picture tube is located. Note casters for easy turning and idle space under set chassis for spare tubes and other parts.

ion trap having a single magnet.

In many TV sets, it is not necessary to alter the damper resistor value. We suggest you try the large screen picture tube, increasing the damper resistance only if the picture does not fill the screen horizontally.

Turn brightness control to its dim position, slip on new ion trap, and position it on neck of new tube until a dim image appears. Now advance brightness control slightly and turn trap, or move back or forward, until image is as bright as it can be made. Regular brightness control may now be turned on full. The purpose of keeping brightness control at a minimum during ion trap adjustment is to prevent burning a brown spot in the center of the picture tube screen.

Philmore

MODEL NT-200

NOVICE TRANSMITTER KIT

POWER
INPUT
25
WATTS

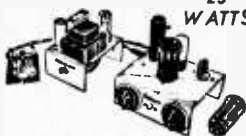

Including Power Supply Kit **\$29.40** AMATEUR NET COST
EASY TO ASSEMBLE—EASY TO OPERATE!! 2 Bands:
3.7-3.75 Mc and 26.96-27.23 Mc. All necessary parts. Tubes.
Key. 2 plug-in coils. pictorial diagrams. included.



PHILMORE is HEADQUARTERS for
CRYSTAL SETS & KITS
CRYSTAL DETECTORS &
ACCESSORIES
HEADPHONES

MICROPHONES

RADIO KITS

1-TUBE—2-TUBE

5-TUBE AC-DC RADIO KITS

HI-FI AMPLIFIER KITS



Philmore is world renowned as Pioneer Manufacturers of Economy Type Electronic Kits and Components since 1921. See these items at your local jobbers' or write for information to Dept. X.

PHILMORE MFG. CO., INC. 113 University Place
New York 3, N. Y.

Miniature Mercury Vapor Lamp



This miniature mercury vapor lamp has a special glass housing to permit free passage of the 1849A and 2537A lines. Provides good supply of short wave ultra violet. May be used also for germicidal or ozone generating purposes. Many colleges are using it as a monochromatic light source (filters needed). Lamp supplied complete with socket & instructions.

Your
Price
\$1.95

SNOOPERSCOPE TUBE

See in the Dark



These are government released British snooperscope tubes which employ the special simplified design, making construction of experimental models possible with simple hand tools. Highly sensitive, they provide a bright clear image of invisible infra red and ultra-violet rays. Also useful as infra red (invisible) photocells. With complete hookup instructions. Supply limited! Special **\$14.95**

NEW REVISED-ENLARGED SNOOPERSCOPE BOOK

Chuck full of interesting information, pictures, diagrams and Hook-up instructions showing in detail Infra Red Telescopes, Snooperscopes, Sniperscopes, etc., that permit clear vision in total darkness by means of infra red energy (heat waves). One of the few books of its kind.

Special Price **\$1.50**

NEW CATALOGUE . . . Send today for our latest enlarged, revised 16 page catalogue of new scientific and electronic supplies. Includes literature and construction data on infra red instruments, 10c. FREE with purchase of any above item. Shows hundreds of scientific items.

PRECISE COMPANY

942 Kings Highway, Dept. 52, Brooklyn 23, New York

Note in Fig. 2, that the original width coil has been completely disconnected and is not used in conjunction with the new H.V. transformer. The 5000 ohms added to the original damping resistor will fill a 17-in. picture, and allow an inch to spare. If you wish to make the picture smaller or larger, use a 7000 ohm, 25 watt adjustable resistor with sliding tap. Sliding the tap down to decrease the resistance will make the picture smaller. Sliding the tap up toward the 7000 ohm end will enlarge the picture to 20-in. size.

All radio supply houses have the components necessary for this big picture conversion, including cabinets, mounting brackets, and hardware. *Warning: Under no circumstances apply power to set when cover of high voltage cabinet is removed. Also be sure 2nd anode plug on side of picture tube is positioned securely as metal clip inside rubber cap is delivering 15,000 volts.*

Some special points relating to 20 in. picture should be noted. In some few instances more screen grid voltage is helpful in the 6BG6G Sweep circuit. If original set is provided with a 22K and 18K resistor terminated on socket lug #8 of 6BG6G, replace these parallel-connected resistors with a single 5000 ohm, 5 or 10 watt resistor.

For even greater picture width (seldom if ever needed), connect a .01 to .05 mfd., 600v. paper capacitor across #5 and #6 lugs of the H.V. transformer. Use as small a capacity as will fill screen since brightness is reduced as capacitor size increases.

When converting a Dumont and certain other extra-quality sets, the damper resistor is left unchanged. In fact, with a 20 in. picture tube as shown in Fig. 1, the picture was 3 in. wider than necessary. To provide full-scene vision, the damper resistance was lowered by moving the upper lead to the lowest tap (the unused lug) on the 50-watt resistor.

Because of the small difference in cost between a 17 and 20 in. picture, we strongly suggest the 20 in. size rectangular tube such as the 20CP4.

Broken Leads Spoil TV

• If your TV picture is weak or flickers, with cross lines over the face of the tube, check the twin lead-in line connections on the back of the cabinet for breaks such as illustrated. In such cases the sound will often make crackling noises if there is intermittent contact at the break in the cable.—H. LEEPER.



General Purpose AC Amplifier

By HAROLD P. STRAND
Electrical Editor

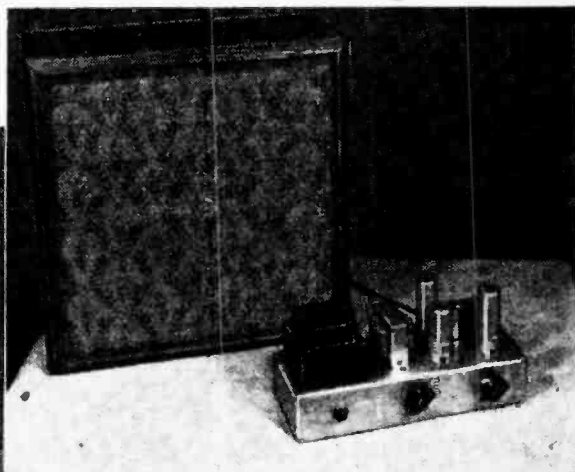
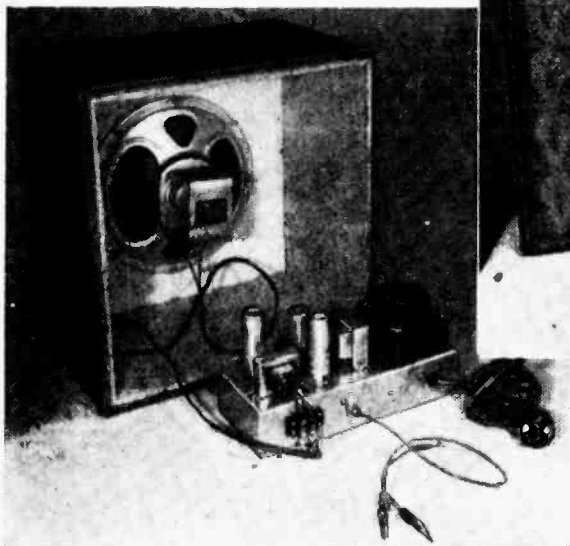

Dwarfed by a large 8 in. permanent magnet speaker unit, this miniature amplifier is capable of outstanding performance, within its 5-watt range.

A rear view of both amplifier and speaker cabinet, showing the connections to the amplifier of line, input and speaker. The 8 in. speaker can be seen mounted on its baffle.

WHILE ac-dc radios and amplifiers are used extensively today and perform quite well under most circumstances, there is no comparison in all-around performance with a strictly a-c, transformer-operated amplifier. The amplifier described here is built around the newer miniature-type tubes that will provide excellent fidelity with records. A radio tuner or indoor mike can also be used with it when combined with a pre-amplifier and the electrical and radio amateur will find it useful for bench work in experiments and testing. Its output of about 5 watts is ample for the average uses mentioned.

The amplifier consists of a 6AT6 voltage amplifier tube and a 6AQ5 beam power output tube, a Stancor P-6119 power transformer, a 16-henry choke, together with two 16 mfd. electrolytic capacitors (as filters), and a 6X4 rectifier tube. (See Materials List for other necessary components.) The signal is fed into the grid of the 6AT6 voltage amplifier through the volume control, and the plate of this tube is capacitor coupled to the grid of the 6AQ5 power output tube. The output from the 6AQ5 is fed into the output transformer. This tube, while small in size, is rated equally with a 6V6.

The output transformer of any amplifier must match the plate circuit to voice coil of speaker. The Stancor A-3877 used here is rated as single 5000 ohm plate to 4 ohms with maximum power output of 5 watts. This transformer was selected because the impedance of the plate load for a 6AQ5 is specified as 5000 ohms and the usual

MATERIALS LIST—AC AMPLIFIER

No. Req'd	Description
1	chassis, made as described in text
1	Stancor power transformer, P-6119, 600 V. 50 ma., 6.3 V. 2.7 amp., (5 V. 2 amp. not used)
1	Stancor output transformer, A-3877, single 5000 ohm plate to 4 ohms, 5 watts or UTC Universal output transformer Type S-14, 10 watts.
1	filter choke, 16-henry, 55 ma.
3	7-pin, miniature shield-base sockets, with shields for tubes listed. $\frac{3}{8}$ " mounting holes
1	1 meg. volume control with switch
1	RCA type phono jack and plug
1	2 terminal Jones strip #140
1	$\frac{1}{8}$ " pipe size Bakelite bushing or rubber grommet
10 ft.	#18 rubber parallel lamp cord (longer if required for speaker con.)
1	attachment plug
3 ft.	#22 shielded wire
1	6X4 miniature type rectifier tube
1	6AT6 miniature type high-mu triode tube
1	6AQ5 miniature type beam power amplifier tube
1	pilot lamp assembly, $\frac{1}{2}$ " open pilot lamp $\frac{7}{16}$ " mounting hole
1	6.3 volt miniature screw base lamp
1	50,000 ohm volume control (for tone control)
2	bar pointer knobs to fit volume control shafts
2	16 mfd. 450 volt electrolytic capacitor.
2	25 mfd. 50 volt electrolytic capacitor.
1	.05 mfd. 600 volt paper capacitor
2	.01 mfd. 600 volt paper capacitor
1	560 ohm 2 watts resistor
1	2700 ohm 1 watt resistor
1	470,000 ohm $\frac{1}{2}$ watt resistor
1	100,000 ohm $\frac{1}{2}$ watt resistor
1	Misc. hook-up wire, bolts, nuts, solder, etc.
1	permanent magnet speaker, 3-4 ohm voice coil, 8" size
1 pc.	$\frac{3}{8}$ " plywood, 12 $\frac{1}{2}$ " x 7 $\frac{1}{4}$ "
4 pcs.	$\frac{1}{4}$ -round moulding, cut to fit front edge
	$\frac{1}{4}$ " Beaver Board to line cabinet and also for speaker baffle
	Grille cloth to suit taste

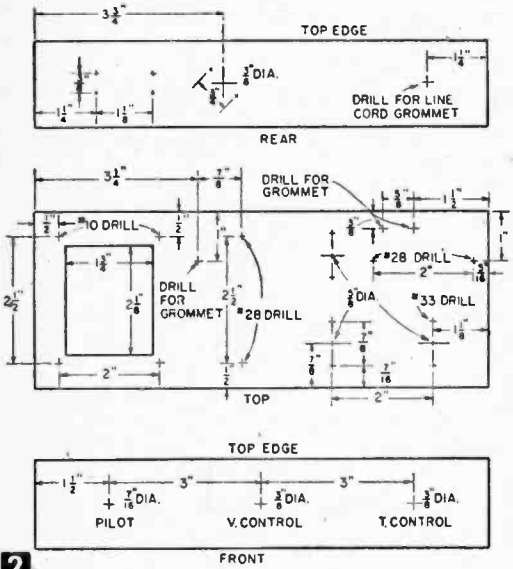
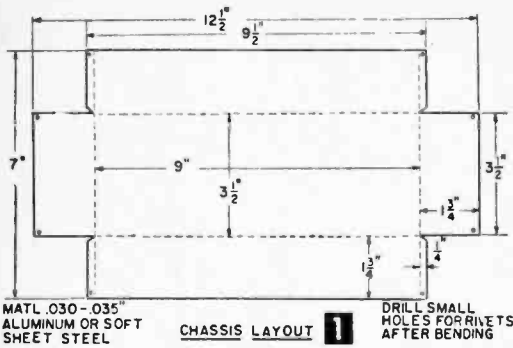

2 speaker voice coil used in a speaker up to 8 in. is around 4 ohms. By mounting this unit on the chassis, the proper connection between output and speaker will always be assured and the only connections necessary will be 2 wires from a terminal block at back of chassis to voice coil. For maximum fidelity and better reproduction, use a larger capacity 8 or 10-watt output transformer. (See alternate listed in Materials List). The larger transformer should match the 5000 ohms impedance of the voice coil in the speaker used. There is not sufficient room on the chassis to mount a large output transformer, but it can be mounted in the speaker cabinet. Simply connect

the two leads shown in the schematic diagram to the primary side of the transformer in the speaker cabinet. A larger 10 or 12 in. speaker will add to performance even more, but you must build a larger speaker housing and use a transformer with a 5000 ohm to 6-8 ohm rating.

The first step in building this amplifier is to make the chassis from some .028-.030 sheet steel or galvanized iron (Fig. 1). The latter can be easily bent and formed and its zinc coating is a good electrical conductor for ground connections to the chassis. Bend on the dotted lines over a piece of metal or hardwood block, using a hammer to get good square corners, or use a bending brake. A single rivet or eyelet at each bottom corner will secure the chassis.

Drill and punch the necessary holes in the chassis (Fig. 2). Alternate layout shown in Fig. 2A may produce minimum hum. The sockets used are miniature 7-pin type, which require a 5/8 in. hole and two 4-40 mounting screws and nuts. The line cord enters at the back of the chassis through a rubber grommet. Also, an RCA phono jack is provided for shielded connections from record player or other input. A terminal block

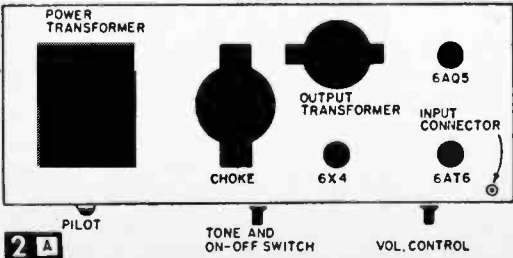
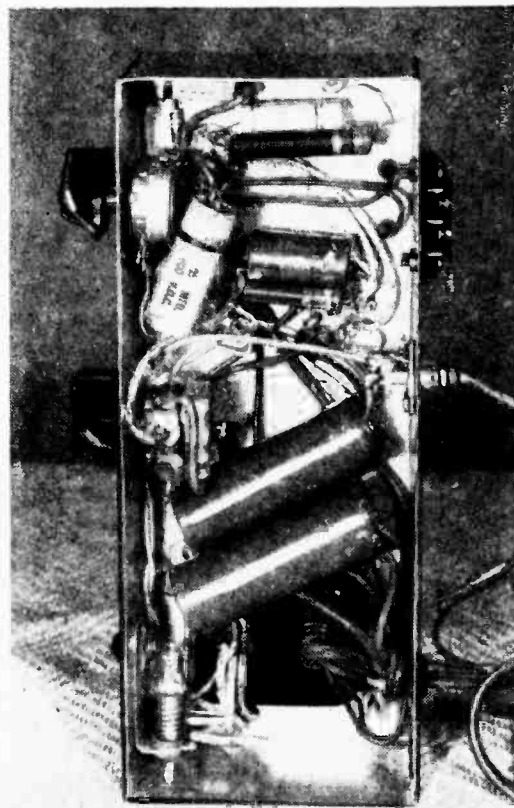

Bottom view shows the 16 mfd. filter capacitors side by side, near power transformer. The shielded leads run from the grid of the 6AT6 and from the input jack to volume control.

at this back side allows connections to the speaker voice coil in a simple manner. At front side of chassis, a pilot lamp assembly is at the left, the volume control in the center and a tone control at the right. The latter is a simple attenuator type of tone control, in the plate circuit of the 6A5. This control regulates the amount of high frequency notes that pass to ground through the condenser. Reducing the resistance reduces the high notes in the output and this tends to accent the bass notes.

The schematic diagram (Fig. 3) should be easy to follow. The tube sockets selected for this job are shield base type, which use tube shields (see photos). These may be eliminated if desired; however, they protect the tubes, hold them tight in their sockets and offer protection from stray fields. To offset their one disadvantage—making the tubes run hotter—shields may be dipped in black lacquer and baked for a short time in an oven. Black absorbs heat from the tubes and radiates it to the atmosphere.

Be sure when wiring the amplifier to follow each connection as shown and solder all terminals and joints. Avoid an excess of solder, which may run down and touch the chassis or ground, causing a short. For best results, observe values of resistors and condensers, together with the transformer and choke; do not substitute other values.

In case of an excessive hum, check to see if the 6AT6 grid wiring is near a-c wires, such as line or heater leads. This grid is the most sensitive part of the entire amplifier and care

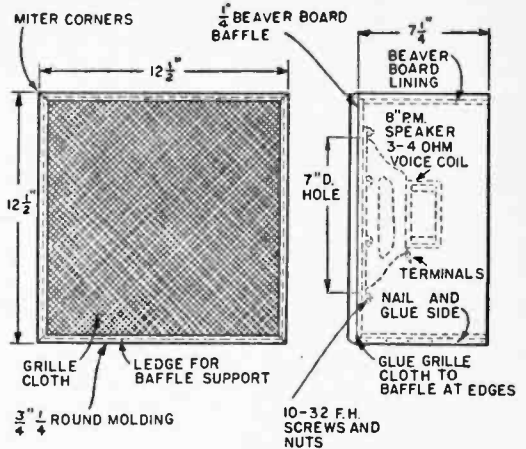

4 FINISH—WALNUT STAIN AND SHELLAC
DETAILS OF SPEAKER CABINET

must be taken to keep all leads as short as possible and shielded. The lead coming from terminal 1 of the 6AT6 must be shielded and the shield grounded. A lead connecting the input jack to the volume control is also shielded, since it is in the grid circuit. This shielded wire is sold in radio stores and its outer metallic sheath is grounded to the chassis by soldering. Do not

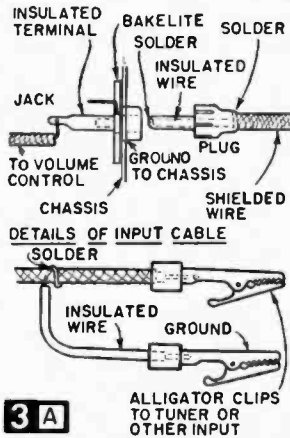

3 A

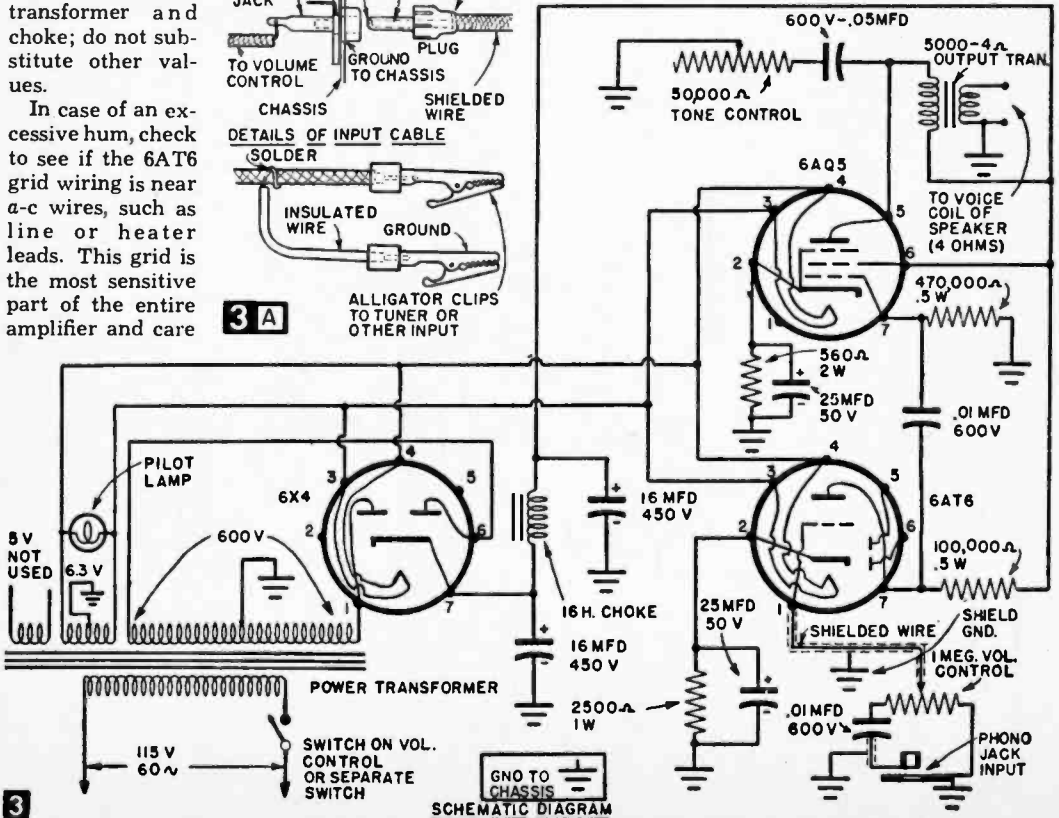

3

SCHMATIC DIAGRAM

allow any stray strands of the shielding to touch terminals. This should be back about $\frac{1}{8}$ in. from any terminal.

Another cause of hum is a choke with too little inductance and filter condensers of too low a capacity. In such a case, the a-c ripple is not fully filtered out of the rectified d-c circuit. A 1 meg. $\frac{1}{2}$ watt resistor from the grid of the 6AT6 to ground may reduce the hum, although the 1 meg. volume control serves as the grid resistor.

Make the cabinet for the 8 in. speaker from $\frac{3}{8}$ in. plywood (Fig. 4). Attach speaker to a piece of $\frac{1}{4}$ in. wall board (Beaver Board) as a baffle, using flathead $\frac{1}{32}$ screws and nuts around the edge of a circular hole. Line inside of cabinet with this same material, after mounting the speaker to greatly improve tone quality. Solder a piece of lamp cord to voice coil terminals of speaker with small terminal clips on the other end, to connect with terminal strip on chassis.

This cord can be made as long as desired, so that the speaker can be mounted out of the way on a wall space. A piece of shielded wire must be used for the connection to input jack. Attach plug of jack assembly to one end of this wire, soldering bared end of insulated wire to end of plug tip and soldering the shield to outer end of plug (Fig. 3A). Solder two alligator clips to outer end of wire, one to the insulated wire and the other to a short jumper from a soldered connection to the sheath. This form of input connection is very handy, as the clips can be quickly attached to various tuners and radio components which you may want to put through the amplifier. If the amplifier is to be used as a permanent part of some record player or radio system, the clips can be dispensed with and connections made direct. The direct connection may also reduce hum in some installations. Use of a separate a-c switch also helps to reduce hum.

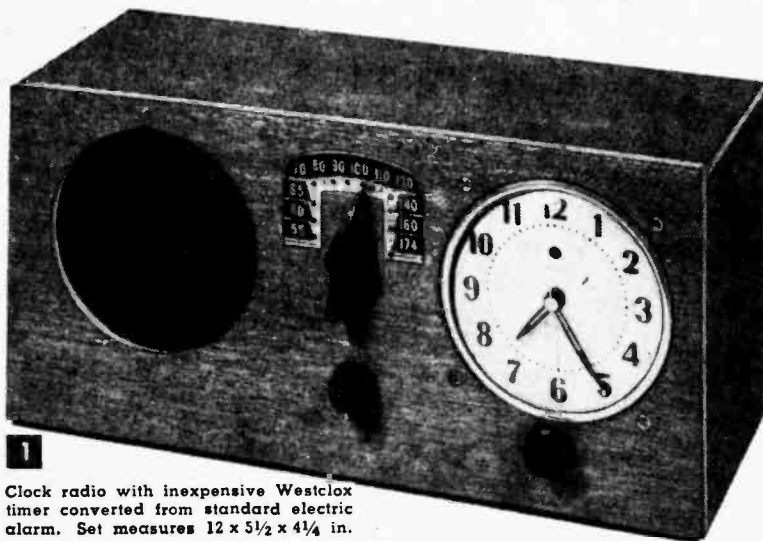

1 Clock radio with inexpensive Westclox timer converted from standard electric alarm. Set measures $12 \times 5\frac{1}{2} \times 4\frac{1}{4}$ in.

Alarm Clock Radio lets you wake up to music!

IF YOU want to start your day with music, here's a compact unit that combines an accurate synchronous timing mechanism with a sensitive 5-tube miniature superheterodyne radio.

During the day, the radio functions like the usual set, but with the flick of a switch, it goes off at night to awaken you next morning at the desired hour. Should you rush off to work and not remember to turn off the set or fall asleep listening to soft music, don't worry! The set will turn itself off automatically after $1\frac{1}{2}$ hours.

I.F. transformers. Because of the high-Q antenna coil, this set requires no bulky, direction-sensitive loop. A 12-inch length of wire secured inside the cabinet with Scotch tape is all the antenna you need. In remote areas, a 6-ft. length of wire will "pull 'em in."

Form the chassis from light sheet metal (either #20 gage aluminum, mild steel or a $7 \times 7\frac{1}{2}$ in. piece of copper may be used). Lay it out according to Fig. 3, cutting the speaker opening with tin-snips. All mounting holes are shown where

In this set, a standard electric alarm clock was converted to an electric timing device by installing a sensitive Acro switch which is actuated by the clock's alarm escapement. If you would rather not rebuild the clock, you can instead obtain one of several ready-made radio timer clock units now on the market (see materials list). These movements have the 3-position switch built into the clock and for them, the separate switch described here is not necessary. Simply wire in the GE, Telechron, or Sessions movement to the points shown in the radio schematic.

The radio itself is a highly efficient circuit employing the latest miniature tubes, and ferrite tuned antenna and

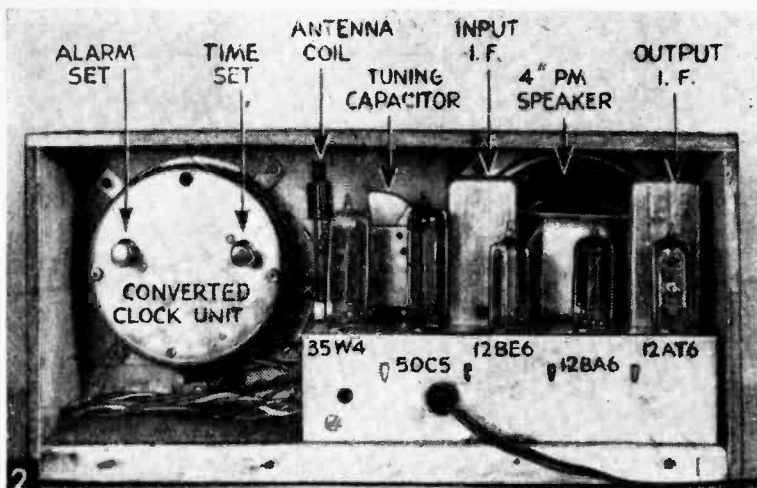

Rear view of clock radio showing converted clock at left with alarm and time set knobs within convenient reach. Note 3-position tap switch directly under clock. The 12-in. antenna is secured to case with Scotch tape.

MATERIALS LIST—CLOCK RADIO

- 1—Radio timer clock GE (General Electric Supply Co., Bridgeport, Conn.); Telechron (Telechron Co., Ashland, Mass.); Sessions (Sessions Clock Co., Forrestville, Conn.); sold by both radio and electrical supply houses in all large cities or 1—Standard Electric Clock, converted as shown in Fig. 4 with installation of 1 Acro switch

CONDENSERS (Capacitors):

- 1—2-section superhet tuning condenser (420-162 mmf. section)
- 1—50-30 mf., 150 v. paper tubular electrolytic
- 3—.05 mf. paper capacitors (150-400 or 600 w.v.)
- 2—.01 mf. paper capacitors (150-400 or 600 w.v.)
- 1—.005 mf. paper capacitor (150-400 or 600 w.v.) (or mica)
- 1—100 mmf. mica capacitor
- 1—50 mmf. mica capacitor
- 1—250 mmf. mica capacitor

COILS (Transformers):

- 1—Antenna coil (Grayburne Ferri-Loop, Grayburne Corp., Yonkers, N.Y.)
- 1—Oscillator coil (3-wire Hartley type; popularly known as 12SA7 456kc* Osc.—Meissner, Stanwyck, etc.)
- 1—Input I.F. transformer 456kc* (Automatic K-Tran, Miller, Meissner, Stanwyck, etc.)
- 1—Output I.F. transformer 456kc* (Automatic K-Tran, Miller, Meissner, Stanwyck, etc.)
- 1—Audio output transformer (popularly known as 50L6 type)

***Also cataloged as 455kc—use either**

RESISTORS

- 1—22 ohms, 1 watt
- 1—150 ohms, 1 watt
- 1—2700 ohms, 2 watt
- 1—22K ohms, 1/2 watt
- 1—24 meg. (or 1/4 megohm), or 220 K ohms, 1/2 watt
- 1—470K ohms, 1/2 watt
- 1—2.2 megohm, 1/2 watt
- 1—10 megohm, 1/2 watt
- 1—.5 meg. vol. control

Note: K = 1,000 ohms. Thus 22K is 22,000 ohms, etc.

TUBES (all miniature types):

- 1—12BE6 Pentagrid Converter
- 1—12BA6 R.F. Amplifier Pentode
- 1—12AT6 Twin-Diode-High-Mu Triode

- 1—50C5 Beam Power Amplifier
- 1—35W4 Half-Wave Rectifier

SPEAKER:

- 1—4-in. PM Alnico #5 type

CABINET

- Front—1/4 x 12 x 5 3/4 in. veneer plywood
- Top—1/4 x 12 x 4 1/4 in. veneer plywood
- Sides—1/4 x 5 1/2 x 4 1/4 in. veneer plywood
- Bottom—3/8 x 11 1/2 x 4 1/4 in. pine, etc. (3/4 mill stock)

CHASSIS

- 1 pc. #20 gage aluminum, copper or steel 7 x 7 1/2 in.
- MISCELLANEOUS:** Hook-up wire, five 7-pin miniature sockets, fixture cord, hardware as required, one 3-lug and two 1-lug terminal strips. Also, 1 bar-pointer knob, and two small knurled knobs; 1/4-in. shaft-set-screw type.
- Note: Amphenol, Na-ald, or similar outlet may be attached across B and C in Fig. 4 for automatic turn-on of a coffee-maker, etc. simultaneously with radio.

standard dimensions apply, but mounting holes for the tuning capacitor (condenser) should be drilled after you obtain this part, since hole positions will vary according to the capacitor manufacturer. Holes for mounting the I.F. transformers apply to the standard 1 1/4 in. size I.F. However, many radio houses stock miniature and sub-miniature transformers, which require a 1 5/16-in. or 3/4-in. square opening, respectively. For maximum efficiency, choose transformers listed as "high-gain" or high-Q types.

Note in Figs. 2, 5 and 7 that the tube sockets are arranged in a straight line across the back of chassis to provide easy access for replacements, and to keep the temperature inside the set down to a minimum (the miniature 35W4 and 50C5 tubes radiate a lot of heat). The miniature wafer sockets are mounted so that pins #3 and #4 are toward the rear chassis fold. This permits all tube heaters to be series wired neatly.

In order to keep the 12BE6, 12BA6, and 12AT6 as close to the I.F. transformers as possible, these tubes are in third, fourth and fifth positions in the chassis socket line-up (Fig. 2). This does

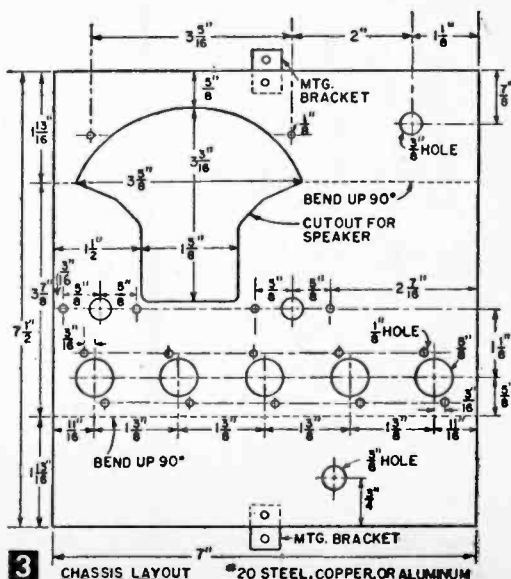

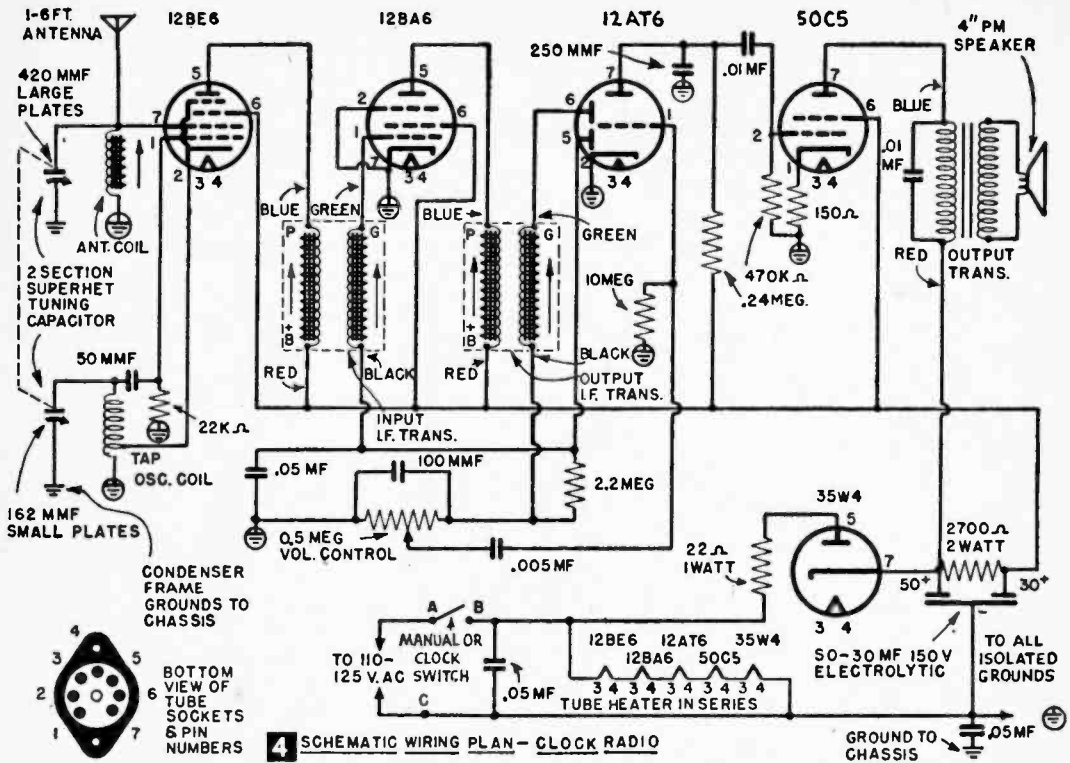

not complicate the wiring, and only the .01 mfd. coupling capacitor has a long lead to connect it from the plate (pin #7) of the 12AT6 to the grid (pin #2) of the 50C5 (see Fig. 4).

Having secured all components listed in the materials list, you are ready to mount parts on chassis. Position the I.F. transformers so the grid connections are as short as possible. Also, connect all control grids of tubes to their respective components with short, direct leads. In wiring

the set, you can use either the "hot chassis" or "isolated ground" system. The first method reduces wiring to a minimum, but introduces the possibility of shock unless the set is completely enclosed in a non-metallic cabinet with a back cover as well. Also, there must be no exposed mounting screws which might contact a grounded metal object, or be touched by humans while the set is plugged into the home lighting circuit.

If you choose this "hot chassis" method, solder all circuit points indicated by the encircled ground symbol in Fig. 4 directly to the set chassis. But if you choose the safer, isolated system, connect all these various ground points to-

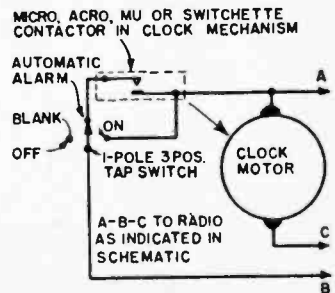
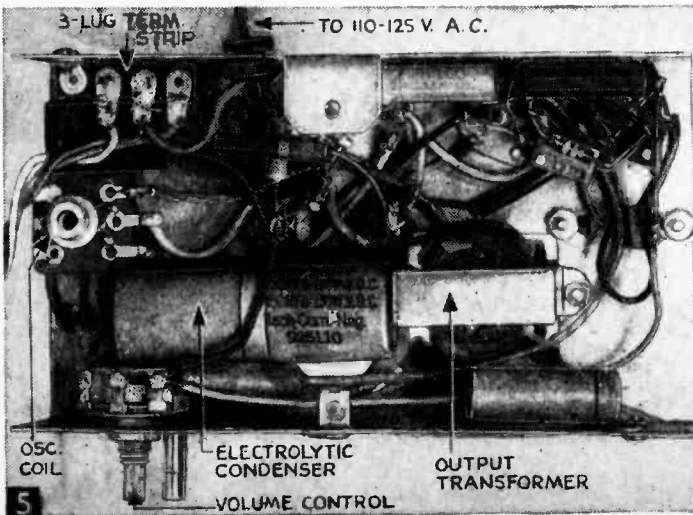

Bottom view of chassis showing location of basic components.



I Will Train You at Home for GOOD PAY JOBS in RADIO-TELEVISION

J. E. Smith, President, National Radio Institute, Washington, D. C., has trained more men for Radio-Television than any other man.

America's Fast Growing Industry Offers You

I Trained These Men



Employed as Transmitter Operator

"A former employer recommended NRI training. Am now operator at Station WKBO." A. Herr, New Cumberland, Pa.

\$10 to \$15 Week Spare Time



"4 months after enrolling, averaged \$10 to \$15 week spare time servicing radios." William Weyde, Brooklyn, N.Y.



Makes Money With Own Shop

"Am doing Radio servicing full time. I owe my success to N.R.I." Curtiss Stath, Ft. Madison, Iowa.

Works on TV Color Control



"My position with WNBT is video control engineer on the RCA color project." W. Deem, Malverne, N.Y.



Praises N.R.I. as Best Course

"I realized a profit of \$300 by the time I completed the course." J. Hopper, Nitro, West Virginia.

TELEVISION



Is Today's Good Job Maker

TV now reaches from coast to coast. Qualify for a good job as a service technician or operator. My course includes TV... you learn by practicing on circuits common to Radio and TV. Mail card. NRI training is a tested way to better pay.

1. EXTRA MONEY IN SPARE TIME →

Many students make \$5, \$10 a week and more EXTRA fixing neighbors' Radios in spare time while learning. The day you enroll I start sending you SPECIAL BOOKLETS that show you how. Tester you build, with parts I send, helps you make extra money servicing sets, get practical experience. All equipment I send is yours to keep.

2. GOOD PAY JOB →

NRI Courses lead to these and many other jobs: Radio and TV service, P.A., Auto Radio, Lab, Factory, and Electronic Controls Technicians, Radio and TV Broadcasting, Police, Ship and Airways Operators and Technicians. Opportunities are increasing. The United States has over 105 million home and auto Radios—over 2,900 Broadcasting Stations—more expansion is on the way.

3. BRIGHT FUTURE →

Think of the opportunities in Television. Over 15,000,000 TV sets are now in use; 108 TV stations are operating and 1800 new TV stations have been authorized—hundreds of these expected to be in operation in 1953. This means more jobs—good pay jobs with bright futures. More operators, installation and service technicians will be needed. Now is the time to get ready for a successful future in Television! Want to get ahead? Find out what Radio and Television offer you. Mail card today!



LEARN BY PRACTICING WITH KITS I SEND—SEE OTHER SIDE

CUT OUT AND MAIL THIS CARD Sample Lesson & 64-Page Book **FREE**

This card entitles you to Actual Lesson from NRI Course; see how you learn Radio-Television at home. You'll also receive my 64-page book, "How to be a Success in Radio-Television." You'll read what my graduates are doing, earning; see photos of equipment you practice with at home. Cut out and mail this card now!

NO STAMP NEEDED! WE PAY POSTAGE

Mr. J. E. Smith, Pres., National Radio Inst., Washington 9, D.C. Mail me Sample Lesson and Book, "How to be a Success in Radio-Television." (No salesman will call. Please write plainly.)

NAME AGE.....

ADDRESS

CITY ZONE STATE.....

The ABC's of SERVICING

How to Be a Success in RADIO-TELEVISION

Learn RADIO-TELEVISION



Servicing or Communications at Home in Your Spare Time

Do you want a good pay job, a bright future, security? Or your own profitable business? Then get into the fast-growing RADIO-TELEVISION industry. Keep your job while training at home. Hundreds I've trained are successful RADIO-TELEVISION TECHNICIANS. Most had no previous experience, many no more than grammar school education. Learn Radio-Television principles from my easy-to-understand illustrated lessons. Get practical experience on actual equipment I furnish. Read below how many make \$5, \$10 a week and more extra fixing neighbors' radios in spare time while learning, get good jobs, build

successful businesses of their own. It's where you find growth that you also find opportunity. Radio-TV industry is growing fast. Send for MY FREE DOUBLE OFFER. Postage-free card entitles you to an actual lesson that shows how practical it is to learn Radio-Television at home. You'll also receive my 64-Page Book, "How to Be a Success in Radio-Television." Read what my graduates are doing, earning, see photos of equipment you practice with at home. Cut out and mail card today... no stamp needed! J. E. Smith, President, National Radio Institute, Washington 9, D. C. Our 39th Year!



You practice with RADIO-TV Circuits All parts I send you are yours to keep

Earn While You Learn



Keep your job while training. I show you how to earn extra money while learning at home. I start sending you Special Booklets that start teaching you servicing jobs the day you enroll. Multitester you build with my equipment helps. Many students make \$5, \$10 and more a week extra fixing neighbors' radios evenings and Saturdays.

Shown at right are just a few of the many pieces of equipment NRI students build with kits of parts I furnish. You use this equipment to get practical experience, make many tests. Practice servicing radios or operating Transmitter. You build Multitester valuable in servicing sets, earn extra money fixing neighbors' radios in spare time... experiment with circuits common to both Radio and Television. All equipment I send is yours to keep.

SAMPLE LESSON PLUS 64 PAGE BOOK—BOTH FREE

FIRST CLASS

PERMIT NO. 20-R

(Sec. 34.9, P.L. & R.)

WASHINGTON, D. C.

BUSINESS REPLY CARD

NO POSTAGE STAMP NECESSARY IF MAILED IN THE UNITED STATES

4c POSTAGE WILL BE PAID BY

NATIONAL RADIO INSTITUTE

16th and U Sts., N.W.

Washington 9, D.C.

Want Your Own Business?

Let me show you how you can be your own boss. Many NRI trained men start their own business with capital earned in spare time. Robert Dohmen, New Prague, Minn., whose store is shown below, says, "Am now tied in with two television outfits and do warranty work for dealers. Often fall back to NRI textbooks for information."



gether with a heavy length of insulated hook-up wire. The chassis is then safely brought to ground potential through the .05 mfd. capacitor shown in lower right corner of Fig. 4. Omit this condenser in the "hot chassis" hook-up.

You will need to mount the tuning capacitor on fiber or Bakelite washers to secure complete isolation. This capacitor is bolted directly to chassis in the simplified hook-up. Whenever possible, obtain a tuning condenser with pre-adjusted trimmers. Otherwise, adjust the tuning condenser screws to bring into alignment with frequency locations on dial. The I.F. transformers are usually precision adjusted to 456 kc at the factory. Therefore, never tamper with the "slug" adjustment screws on these, or an expert radio serviceman will have to be called in to re-align your set.

You can, however, adjust the ferrite antenna coil for peak efficiency yourself. This coil (about the size of a cigaret) has a sliding core which provides for precise tuning to a degree far surpassing that of the conventional metal plate capacitor. With the radio set tuned to a station in the center of the dial or as near to 1000 kc as possible, slide the core in and out of the coil until the station comes in at maximum volume. (For accuracy, pick a weak station if possible.)

A hole in the ferrite core permits a matchstick to be inserted when sliding it in and out so as to eliminate body capacity. Once the coil is correctly positioned, secure it permanently to the coil form with a dab of Duco cement. When dry, remove the matchstick. Then, with an insulated screwdriver or a wood stick with a whittled blade, adjust the trimmer screw at 1000 kc on the osc. section of the tuning capacitor (section with small plates) until stations come in at proper positions around the dial.

The volume control is a 0.5 megohm potentiometer without the usual ac line switch, since switching is accomplished by the clock. However, if you just want the radio without its clock, obtain a volume control with built-in switch.

Note in Fig. 4 that the 110-to-125 ac line voltage cord terminates on lugs A and C of a 3-lug insulated terminal strip. The electric clock is permanently attached to A and C. Connect the switch in the clock across lugs A and B (Fig 4). If you use a commercial clock, connect the clock motor and switch as shown in Fig. 6. (Lead B feeds directly into the switch in clock mechanism; disregard 3-position switch.)

The simple box-like cabinet structure (Fig. 8) consists of 1/4-in. veneer plywood for the front, top and sides, with a 3/4 in. pine bottom. (Actual

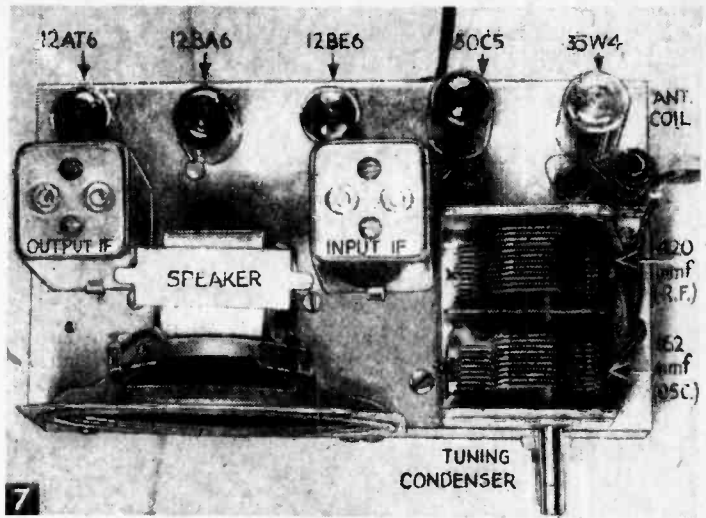

Top view of chassis showing component positions.

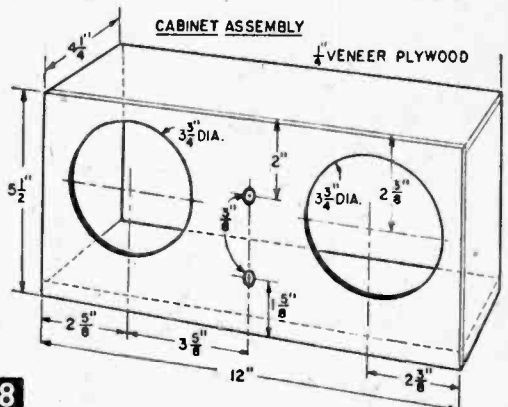

mill size thickness is 5/8 in., of course.) Cut sections to size, drilling out speaker and clock opening with a "fly-cutter" or a jigsaw. Since the clocks are available in both round and square models, and they also vary in diameter, obtain your clock movement before drilling or sawing the clock opening.

Assemble the cabinet with casein or hide glue, reinforced with 3/8-in. brads. Two holes are drilled in the bottom of the cabinet for securing the chassis. Mount felt or rubber feet in each corner of the base to prevent scratching furniture. Glue a piece of speaker grill cloth or perforated metal grill or both behind speaker opening. The dial, a metallic paper type sold by many radio suppliers, is cemented to cabinet with Duco cement. These dials come in left and right-handed types to match tuning capacitors which are made with clock and counterclock-wise plate meshings. If the tuning capacitor plates are fully open when turned to the right, dial should have 174-160 on the right and 550 on the left. But if plates are open with capacitor shaft turned to the left, dial should have 174-160 on left, 550 on right side.

For weak signal areas, the 12-in. length of antenna wire attached to the antenna coil need not be replaced with a 6 ft. length of dangling wire. You can achieve the same effect by cementing a sheet of aluminum foil inside top of cabinet and attaching the 12-in. wire to the foil, after scraping off enamel insulation to insure good contact. Just be sure foil does not contact speaker frame as this would make set inoperative. A short wood

screw and washer make a fine connection between foil and antenna wire, and the excess portion of the 12-in. length may be clipped off to fit from coil to foil.

Radio experimenters will be well repaid by building this set, which costs much less than any similar commercial type, and has 5 instead of the 4 tubes found in many of today's clock-radio combinations.

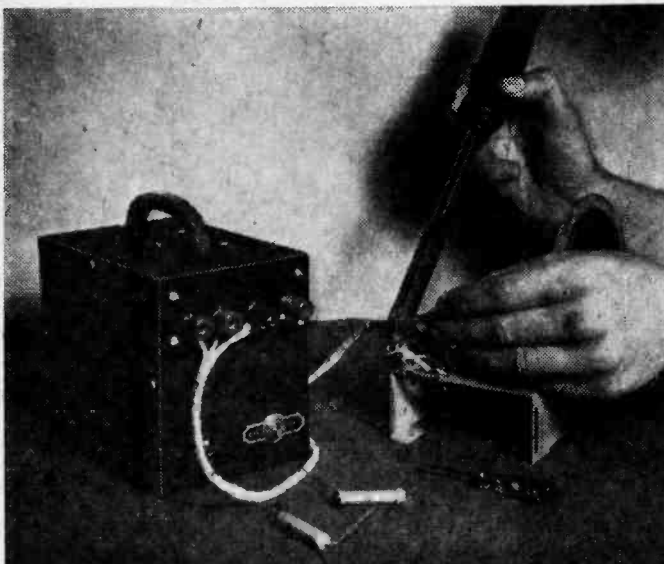

With switch in "off" position, experimental work may be done with safety using this power pack.

With this power supply on the bench, you can try an almost endless number of radio circuits, such as two and three tube regenerative and TRF receivers, phono and home intercom audio amplifiers. By doing away with the power supply components and attendant wiring on the experimental chassis, the usual formidable tangle of parts and wires can be partially eliminated. With only the radio frequency and/or audio sections to wire up, better layout and a greater simplicity is gained.

The 4 x 5 x 6 in. metal cabinet has removable side panels which facilitate mounting and wiring the components. There may be some variation in the size of the parts selected by the individual builder. To avoid crowding it will be best to assemble all the parts first and check them for size.

Use a piece of Bakelite or similar insulating material, 1 $\frac{3}{4}$ in.

Safety Power Pack

By CLINTON E. CLARK

THIS safety power pack furnishes 6.3 volts for filaments and 90 to 100 volts of filtered current for the radio builder who likes to make small, experimental layouts. The safety feature derives from the fact that, although half wave rectification is used, the ac house current is completely isolated from the stages that follow. Thus the caution which must be observed to guard against accidental contact with the line voltage is eliminated.

For the experimenter's use, a power supply of this type will prove a time saver, doing away with the necessity of shielding all metal parts of the equipment with a non-conducting panel or cabinet. Now the metal chassis can be handled with safety. The subpanel components, resistors, condensers, etc., are easily available for substitution or measurement when the trial and error method of experimental work is being done.

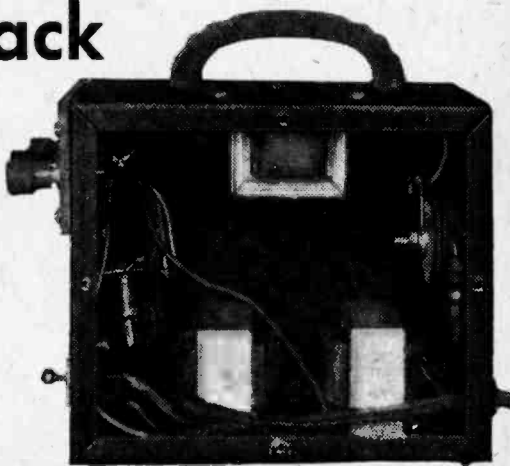

Inside view of safety power pack shows arrangement of parts.

wide x 4 in. long, for the terminal strip. Select binding posts with brightly colored plastic tops to indicate the voltages available. Two green

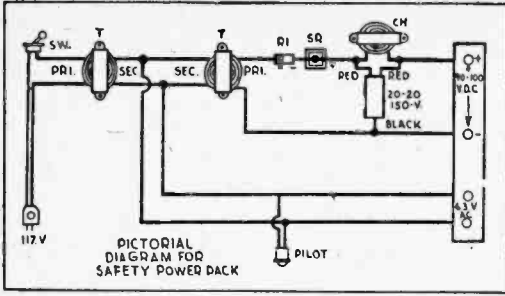

terminal is indicated by a plus sign or a dab of red paint, the negative is unmarked. If not marked in this manner the terminals will be color coded, with red terminal indicating the positive side. This polarity must be observed.

The job completed, you have a handy, compact source of power that will serve well in experimental construction and for the occasions when a low voltage source is needed for testing and repair work.

Bushing for TV Line

posts denote the 6.3 filament voltage, black for "B" negative, red for "B" plus. This particular type is desirable because it also has a hole in the top to take a standard banana plug (small device commonly used as a tip for test leads). With the terminal strip cut to size and the binding posts mounted, determine the portion of the cabinet which must be cut away. This cutting may be done in several ways, depending on the tools available to the builder. Make four large holes in each corner of space marked to be cut away and saw out waste with a small, pistol grip hack saw. If an electric drill is used to outline the cut it will be necessary to do some work with a file to make a smooth job. Mount terminal strip before removal of side panels, since rigidity is helpful when sawing or drilling.

- To bring TV twin-leads into the house with low-loss and without letting cold air in, make sealed feed-through bushings from polystyrene tubing. For 300-ohm line, bore a 1/2 in. dia. hole through window frame and push a length of 1/2 in. O.D. polystyrene tubing through the hole, al-

Now mount the two filament transformers, filter choke and other parts. Use a fairly heavy, (No. 16) well insulated flexible wire for wiring, taking care that the wiring and terminal points are insulated against contact with the metal case.

For those who have not used a selenium rectifier stack, the mounting hole in the center is insulated from the discs to the rectifier and may be bolted directly to the metal case. The positive

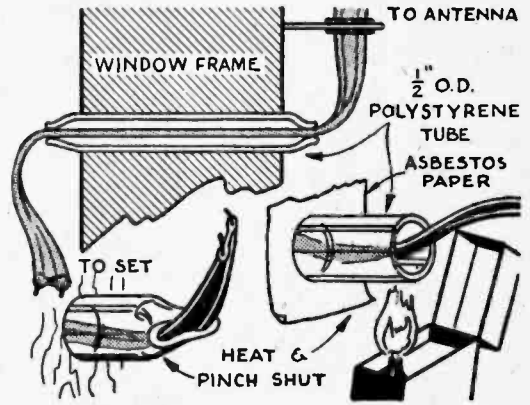

lowing about 1 1/2 in. of tubing to project on each side of frame. Push line through tubing. Seal tube ends by heating with matches or a cigarette lighter, and, wearing a glove to protect the fingers, pinch the tube ends firmly together. Hold until plastic sets. For 150-ohm and 75-ohm twin-leads use smaller diameter tubing.—A. TRAUFFER.

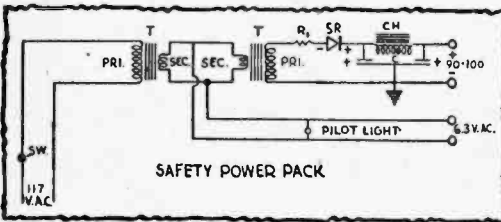

Split Dowel Holds Nut

- When a nut is to be placed in an inaccessible location, hold it at the end of a dowel rod which has been split by making a deep saw cut. The tool will hold nuts of almost any size and is easily withdrawn once the nut is started.—KEN MURRAY

MATERIALS LIST—SAFETY POWER PACK

- Single pole, single throw toggle switch
- T-T 2-6.3 volt, 3 amp. filament transformers
- PL—Red jewel light assembly with 6.3 volt bulb
- R1—51 ohm, 2 watts
- SR—Selenium rectifier, 75 ma or higher
- C—Dual 20-20 mfd, 150 volt condenser
- CH—10 to 20 Henry 75 ma or higher
- Cabinet Bud CU 729 or larger if necessary
- 4 ICA combination posts
- 6 ft. ac cord and plug
- Plastic handle

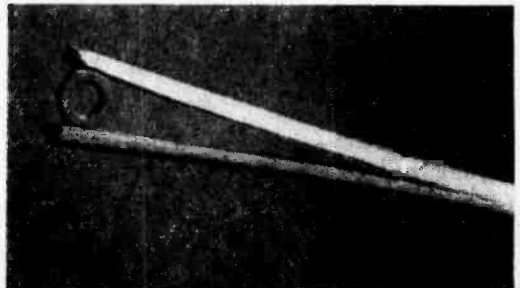

Do You Pay Too Much For TV Servicing?



Survey shows that from 20 to 95% of TV servicing and repair work is done in the customer's home, the percentage depending on the facilities and method of operation of the servicing organization.

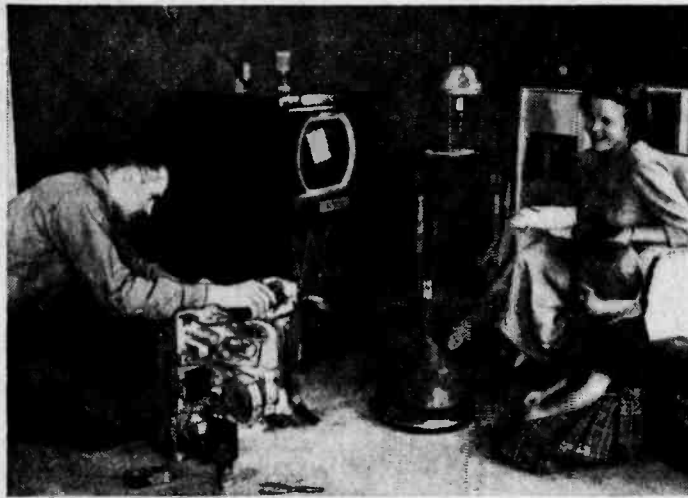

Many servicemen find it difficult to carry with them the number of parts and testing equipment necessary to make repairs in the home.

THE servicing of TV sets is big business. Close to a billion dollars has been paid out already by some 10 million proud owners of TV sets, to keep the sets running and install the required antennas. That's more money than servicemen ever dreamed of in the days of radio. But why does it cost so much to keep a good-looking picture on a TV screen and are the charges for service contracts and individual service calls fair and just? In short, how much should you pay?

Here's the picture on what you should pay and why, and how to avoid budget-breaking servicing bills

By JOHN MARKUS

Associate Editor,
Electronics

An answer to the first question is shown in Table A, which gives the results of a survey of reliable service organizations conducted by the staff of the McGraw-Hill publication *Electronics*. Column 1 in Table A is based on the experiences of organizations set up by one TV receiver manufacturer to fix only his type of receiver. His servicemen need only be familiar with the one make of set, and can carry in their truck nearly all the parts that they may need. Under these conditions, about 95% of the sets can be fixed right in the home on the first call.

Figures in Column 2, Table A come from firms that fix all makes of sets. With way over 75 different makes of sets in use, each having an average of 10 different models a year, such a serviceman can't carry spare parts and tubes for all these sets in his truck or even keep them in stock in his shop. This is why an average of 70% for calls completed in the home on the first trip is considered excellent for the independent serviceman.

All too common, unfortunately, are the independent service organizations that employ low-salaried field men who know little more than how to replace tubes and remove the chassis. The percentage figures for repairs done in the home may drop to as low as 20% for these firms, which means you are deprived of your set for days or even weeks. More about this later, when the cost of servicing is taken up. The survey showed an average of 5 calls per set was made during the first year of a service contract. To see just what these calls were for, let's discuss each item in Table I.

Just as in radio sets, a defective tube is by far the commonest cause of TV receiver trouble.

With an average of around 20 tubes in a set, however, finding the one guilty tube is by no means simple. Furthermore, TV receiver circuits are so critical that many tubes cause trouble when they've aged just a little—so little that ordinary tube testers would pronounce them brand-new. For this reason, you'll rarely if ever see a tube tester in a television serviceman's truck or shop. Instead, he'll have a large stock of new tubes and will try them one by one until he finds one that restores operation. Table B lists the most frequent offenders among tubes. Some require selection, which means that it may be necessary to try as many as a dozen new tubes of that type in order to find one which works well in that particular set.

On 5 to 8 out of every 100 calls, the serviceman must put in a new picture tube, which is the most expensive replacement part in the set. It costs the serviceman himself \$35 to \$40 for the popular 16-in. size. But don't feel sorry for the serviceman. On a first-year service contract about half the picture tube failures occur during the first 3 months of the contract year, when they are covered by the standard 90-day warranty of the set manufacturer and hence are replaced free. The trend now is toward free replacement of picture tubes during the entire first year, under a manufacturer-serviceman contract wherein the set manufacturer replaces all defective parts for a blanket price of \$5 to \$20 per set, paid by the serviceman or dealer. This takes some of the gambling risk out of fulfilling a service contract, and should eventually mean lower contract rates to the set owner.

Antenna Troubles

Antennas are probably the most talked-about part of a TV installation, because they are so prominent on roof-tops. Many set owners, in a keeping-up-with-the-Jones spirit, insist on having a separate high-band antenna just because their neighbors have one. Modern conical antennas (the ones that look like a 4-legged spider) are so effective on all bands that in some locations they even outperform a separate high-band antenna. If the customer insists—and the customer is always right in business-wise organizations—the serviceman will put up the high-band Christmas tree just for appearance, without connecting it at the top.

Antenna troubles increase with distance from the television transmitters, and also they have been found to increase with the number of stations on the air. As localities reach their legal

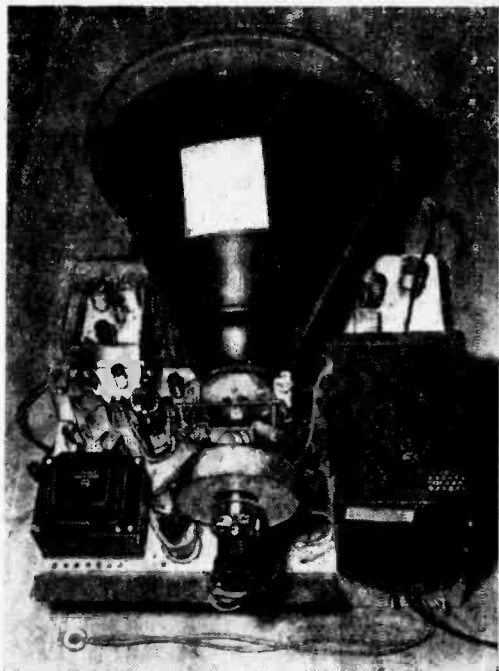

©C.A. Victor photo

TABLE A—REASONS FOR TELEVISION RECEIVER SERVICE CALLS

Reason for Call	Percent of Total Calls Made	
	1 Manufacturer's Service Organizations	2 Independent Service Organizations
Replace receiving tube	30%	32%
Replace picture tube	8	5
Work on antenna system	10	14
Unnecessary call	13	11
Repair or replace tuner	7	3
Readjust back-of-set controls	2	12
Replace paper condenser	6	4
Replace resistor	6	4
Replace electrolytic condenser	3	3
Replace other parts	5	4
Repair poorly soldered joint	5	1
Change circuit design	2	3
Realign set	3	4
	100%	100%

Tubes are the commonest cause of trouble in television sets, just as in radios, but the same rule holds for both: An old tube that still works has just as much chance of lasting another year as does a brand-new tube. In other words, you can't predict when a tube will fail. In this typical TV set, there are 32 tubes to suspect when trouble occurs, but fortunately the nature of the picture trouble gives clues to defective tubes.

quota of stations, antenna calls go down, since the required compromise orientation for all the stations is made at

the time of installation. Antenna repairs are rarely needed during the first year, but increase fast in second and third years. Twin-lead transmission lines deteriorate from sunlight and weather, causing gradually poorer pictures. Since new line costs only a few dollars, it's wise to replace line that looks weatherbeaten, particularly if the insulating web between the 2 wires has softened and allowed the wires to come closer together anywhere.

Antennas and masts naturally rust and corrode with time, particularly if hardware used on the initial installation was not hot-dip galvanized or otherwise protected against rust. When installations are 2 or 3 years old, an entire new and modern antenna system is often the best pos-

sible way for rejuvenating picture quality. The figures of 10 and 14% (Table A) for antenna system work cover 4 years of calls, hence apply to repairs and replacements. It might be pointed out here that many second- and third-year service contracts specify in small print that antenna replacement is not included. Figure about \$20 for replacing the average installation of a television antenna in such cases.

Dry Runs

Most unnecessary calls, which occur as often as 1 in 10, can be blamed on human nature. Even though they have made definite appointments for a service call, many women persist in "just stepping next door" at the appointed time, or even forget all about it and go shopping.

Transmitter trouble is another reason for dry runs; many people won't bother to try other stations or wait for the picture to come back on, when they know they're entitled to have a serviceman come out for free under their contract.

Misrepresentation by salesmen as to the capabilities of a set or the merits of built-in antennas also rank high as reasons for false calls, and here the serviceman must become a diplomat. Interference by transmitters in other types of communication, and oscillator radiation from other TV receivers, about which little can be done, also waste the serviceman's time and gas.

Finally, there are calls where work must be done just to retain good will or prevent bad will, even though the serviceman has no responsibility. Topping the record in this direction is one Brooklynite who got 17 free service calls without a service contract, by writing lengthy and vitriolic letters to the manufacturer of what was really a well-made set, and by even

threatening to have his entire family picket the cut-rate store from which he bought the set. Fortunately such chiseling is rare outside of New York City.

Highly Technical Troubles

Tuners, the most critical parts in a receiver, rank high as troublemakers among manufacturer's service organizations because less skillful repairmen touch these only as a desperate last resort. Tuners can be carried in the service truck for one make but not for all, hence one serviceman will put in a spare tuner while another will get around the trouble by readjusting the controls or realigning. Fortunately, improved tuners in 1951 sets are giving little trouble.

Specialists in one make of set can generally go right to the cause of the trouble and fix it, whereas independents often get around the trouble by readjusting, just as with tuners. Thus the greatest difference in percentages, 2% versus 12% (Table A) occurs for readjusting back-of-set controls. Some repairmen also count on the psychological value of actually doing something to a set even when the picture is of acceptable commercial quality for the particular make involved. Troubles due to bad resistors, condensers and other parts run much the same as in ordinary radios. These defects are often hard to find and require troubleshooting instruments that are best kept on the shop bench. When tubes are cleared of suspicion and there are no obvious defects, the independent man will generally pull the chassis and take it to the shop for troubleshooting, whereas the manufacturer's man will stick it out longer and try to find the guilty resistor or condenser by making measurements in the home. The latter carries spare res-

istors and condensers in his truck for just such jobs. As a general rule, the cheaper the set, the more likely are small parts to go bad.

Joints are checked carefully by manufacturer's men because they've seen in the factory how easy it is to miss a joint on a chassis that moves past each assembler at the rate of

Here is just part of the equipment carried in the service truck of one manufacturer's service organization in order to achieve their record of completing 94% of all service calls in the set owner's home. Now that rectangular picture tubes are appearing in new sets, still more picture tubes will have to be kept in the truck's stock to do home servicing.



about one a minute. Some servicemen just cannot understand how a joint could get out of a factory without being soldered, hence they don't look very hard at the joints. Instead they offset the high resistance of a bad joint by replacing an average tube with one that is better than normal or by adjusting the screwdriver controls to compensate. Not all sets are in perfect condition when they leave the factory. Some may have design mistakes; others may work only in certain localities because they were not properly field-tested in different cities having various combinations of channel allocations. First runs of a new model therefore require changes in circuit design occasionally, once the design defect has been unearthed. It may be nothing more than changing the size of a resistor, but still it requires a service call. Set realignment is a bench job because it requires costly special instruments. One reason for realigning is to shift the intermediate-frequency value of the receiver when 2 sets in the same building are interfering with each other. Fortunately only 3 or 4 out of every 100 calls involve this time-consuming adjustment.

To sum up: when a TV set goes bad, the chances are 6 in 10 that the trouble is in a tube, the antenna or in the customer—all fixable in the home if the normal supply of spare tubes is carried in the serviceman's truck. The remaining 4 calls in 10 involve technical repairs that are done either in the home or at the shop, according to the policies, equipment and ability of the serviceman.

Now for the second question—are television service charges fair and justified? This question has 2 answers, depending on the ethics of the serviceman. First of all, no honest and conscientious service organization has gotten

TABLE B—TUBES THAT GO BAD MOST OFTEN IN TV SETS

Type	Purpose	Nature of Failure	Remedy
6J6	Oscillator	Microphonic (affected by slight vibration)	Select nonmicrophonic new tube
12AT7	Converter	Does not oscillate on high channels	Select new tube that will oscillate
12AU7	Video amplifier	Microphonic	Select nonmicrophonic new tube
6SN7	Sync	Open filament; gassy; intermittent; low gain	Try new tube, selecting from several if necessary
5V4 & other damping tubes	Damping	Flashover, causing burnout (usually due to sagging of heater)	Replace tube
6BG6G & 19BG6G	Horizontal output	Dead tube, due to gas let in by electrolysis at top connection Picture can't be spread out to fill width of screen because tube is near lower limit of sensitivity Black line at edge of picture due to Barkhausen interference	Change to more recent make of new tube, most of which now use leaded glass to avoid this Select new tube that is near upper limit of sensitivity (has high gain) Try new tube or place magnet around old tube
5U4 & other rectifiers	Rectifier	Loss of emission; open filament	Replace tube; may need frequent replacement as these tubes are overworked in some sets

Expensive picture tubes need replacement in 5 to 8 out of every 100 service calls. Usually this can be done right in the home, rather than on the bench as shown here. Most servicemen no longer bother with gloves and goggles but do use care in handling tubes.

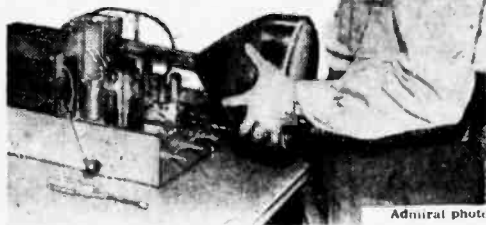

rich on TV service contracts at present prices, which run around \$65 a year on the average for a 16-in. set. About \$25 of this goes for installing the set and putting up a good antenna system—a 2-man job. Additional calls involving antenna adjustments also require 2 men, one to rotate the antenna up on the roof while the other watches the picture. Comprehensive liability insurance must be carried for these servicemen, since TV sets have dangerously high voltages. A truck is needed to carry the

necessary ladders, costly special test equipment is essential for bench repairs, and commissions must be paid to salesmen who get the service contracts, or an equivalent amount spent on advertising. When parts fail during the guarantee period, it takes time, transportation, expense and a lot of bookkeeping to exchange the old part for a new one at each manufacturer's distributor, even though the new part is free. Salaries are higher than for radio servicemen because of the increased technical knowledge required and the present scarcity of skilled TV servicemen. These factors, to mention a few, contribute to a high fixed overhead that actually

leaves not nearly enough dollars to cover the time and materials for the 4 or 5 additional calls made per year on the average. What's left, if any, is the profit of the owner for his own time and for the capital he has invested in the business.

Service Racketeers

The second answer is not pleasant.—Some racketeers and gyps are cleaning up in TV servicing today, particularly in large cities like New York. It isn't just a few piddling dollars per customer—such as the occasional radio servicing gyp got by padding a repair bill. It's big money. Television is new and mysterious. Taking advantage of this, fast-talking promoters can easily separate their victims from over a \$100 year on the sale of a set and its service. Here's how these shakedown artists work their most popular racket—the 3-way switch.

A fraudulent dealer advertises new TV sets at an astonishingly low price—perhaps \$139.50 for a 16-in. table model. You visit his store, and are shown an attractive set made by a well-known manufacturer. To get it, however, you have to pay an installation charge of something like \$20 or \$25 plus city, state and federal taxes (usually included in the advertised prices by reliable dealers), and you are required to take a one-year owner's service policy costing anywhere from \$50 to \$80. You may even be asked to pay the factory charge of \$5 to \$10 that service organizations usually pay to get parts guaranteed for one year. This all totals up to more already than legitimate dealers get for selling, installing and servicing that same set. But this is only the beginning, according to reports coming in to Better Business Bureaus in many cities.

The fraudulent cut-rate dealer sends out to you a sub-

Realignment of television receiver, required in 3 to 4 out of every 100 calls, requires test equipment like this, costing well over \$500, plus knowledge of how to use each instrument properly. Some of these instruments are even needed for such apparently simple jobs as troubleshooting to find a bad condenser. This is just one reason why competent television service costs more than comparable radio repairs.

stitute make of set, or even a rebuilt job, claiming there's a shortage of the brand you looked at and making lavish claims for the one he actually peddles off on you. Being anxious to start watching television, and figuring you're protected by the owner's service policy anyway, you may accept the substitute. Sooner or later, the set goes bad. You telephone the dealer, who says he does not provide the service. Sarcastically, he suggests you read your policy; there you find in fine print the name of some other service company. (Your racketeer dealer boosted his profits still higher by turning the contract over to a shady service organization for half or less of what you paid, pocketing the difference.)

You call the service company and get promises, but nothing happens. You try the dealer again, and get more buck-passing. You get desperate and write the manufacturer of the set, who disclaims responsibility and refers you also to the serviceman who holds your service policy. No one—not the manufacturer, not the dealer, not the serviceman—cares about the faulty set you were switched to. That's the 3-way switch.

There are many variations of this television servicing racket, in some of which even some larger cut-rate dealers are involved. Most of them involve turning your service contract



Minnesota Mining & Mfg. photo

Antenna troubles are responsible for a high percentage of service calls. Much of this trouble can be eliminated by correct initial installation, which includes covering exposed connections with No. 33 Scotch electrical tape as shown here.

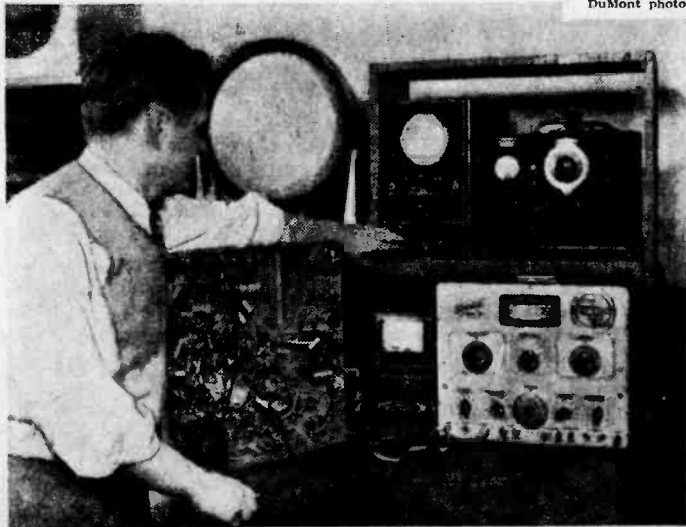

DuMont photo

over to another unreliable service organization that has only one interest—to make as much money as possible on the deal. They use the lowest-salaried help they can get, and what happens to some of the TV sets these boys work on is pitiful to see. They like nothing better than to take a set into the shop and let it set there for weeks or even months on the pretext of waiting for some spare part. All this time the service contract is running out its year, and you are missing TV programs. This firm might have got only \$20 for the contract that cost you \$50, so naturally they couldn't keep your set fixed properly even if they were honest. Still worse is having the service organization go bankrupt during the year of your service contract. Then nobody is responsible, and you're out a neat bit of money. But TV servicing racketeers can exist only as long as money for new contracts keeps pouring in. At the first lull in business they fold, since they just don't have capital set aside to take care of the unfinished service contracts on their books.

In television, as in everything else, the safe

procedure is to avoid cut-rate or something-for-nothing deals. Buy your set from a reliable dealer who handles service contracts himself or turns them over to a service organization that is unquestionably reliable. Read all the fine print in the contract. Ask other set owners how they like their service organizations. Better yet, call the local distributor for the make of set you have, and ask them to recommend a good service organization. If you can't locate the distributor, ask your local Better Business Bureau if they've received complaints about the firm under consideration. Support the honest service organization, and you'll enjoy television a thousand times more. You'll get good clear pictures every night; prompt action on your call for service, with the work done right in your home 7 times out of 10; no false charges for unneeded extras such as boosters or fancy antennas, no apoplexy or ulcers from trying to get action out of a fast-talking gyp who knows only promises and excuses. Yes, it does justifiably cost money to keep a television set running—but it's worth it, say those who see what they hear on the air.

Power-Line Antenna for Crystal Set

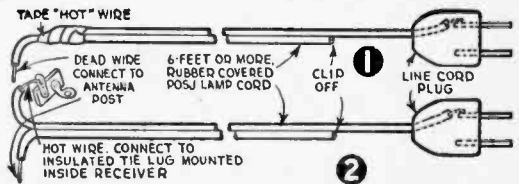
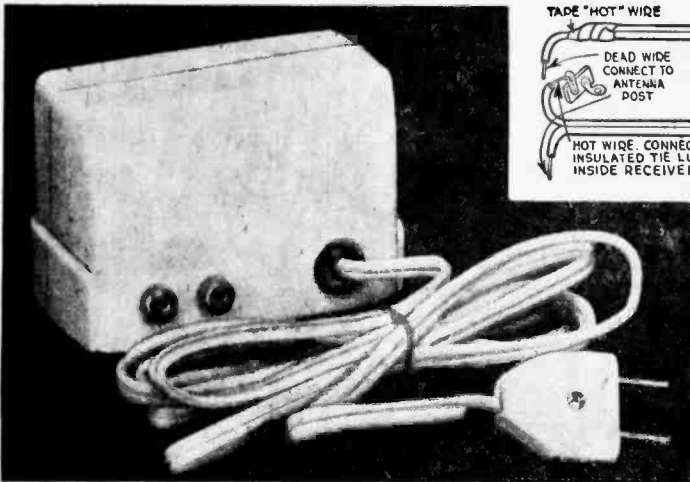

lines but ac current is blocked and cannot enter the receiver. Clip off the dead wire so it cannot enter plug, and thoroughly cover live wire on receiver end with tape.

An alternate method is to connect the hot wire to an insulated tie lug mounted inside receiver (Fig. 2). This makes an efficient antenna for crystal sets and allows the set to be used in any room of the house

HERE'S a simple and efficient power-line antenna for use with a crystal set that will bring in stations from near and far and requires no conventional blocking capacitor. It does away with the antenna nuisance, allows the set to be used in any room of the house, and makes it look like a real midget ac table model but draws no current.

A 6 ft. length of POSJ lamp cord and a plug are all you need. Connect one side of lamp cord to one prong of plug (Fig. 1), but allow other side of cord to remain free. Thus the dead wire is capacitively coupled to the "hot" wire and no conventional capacitor is needed. When the dead wire is connected to the antenna post on a receiver, it picks up r.f. energy from the power-

lines simply by "plugging in." This antenna will work on other sets but the noise picked up from the power-lines will be annoying. The longer the cord, the greater the amount of r.f. picked up from the power-lines. On the crystal set, a 6 ft. length of cord brings in local stations with good volume without a ground connection. When using a bed spring as a counterpoise in addition to the 6 ft. line cord, local stations have worked a magnetic speaker and distant stations have been received in the earphones after the local transmitters have signed off for the night. For the best results, reverse the line cord plug in the wall socket for maximum signal pick-up. In some cases this results in a decided change in volume.—ARTHUR TRAUFFER.

Listen with a Transducer

By T. A. BLANCHARD

HERE is a neat little transducer that can be applied to any type of headphone, or headset. You will hear everything—even a faint whisper—bell clear, without any earphone over the ear. Moreover, the system can be practically invisible, if for example, you might presently use a hearing aid.

The phone attachments shown here are generally known as *transducers*, coined from transmitter and *reproducer*. The sound waves generated by the moving diaphragm of a headphone, instead of going directly into the ear canal, travel through a light and very flexible vinyl plastic tube. This tubing is nothing more than a wire insulation known and sold as *radio spaghetti*. All radio suppliers have it in various diameters and colors including transparent types. Single headphones of all-plastic construction make excellent *transducers*. Remove the phone cap, and diaphragm. Drill a $\frac{3}{32}$ in. hole in the back of phone (B). Into this hole insert a suitable length of $\frac{3}{32}$ in. vinyl tubing; allow to project inside the receiver about $\frac{1}{8}$ in. Secure with several drops of Duco cement. Do not plug up the tube opening.

Replace diaphragm and cap on receiver, attaching a piece of Scotch electrical tape over the cap to seal the sound perforations or hole. Sound waves are generated both from the front and back by an earphone diaphragm. The vinyl tubing coming out of the back of the case provides the most convenient method of installation.

The molded eyelet in earphone case (C) provides for attaching the phone to your person. Solder a small safety clasp to a bead key chain

so the *transducer* may be pinned to lapel or shirt. Or, thread a shoestring through the eyelet, and wear the reproducer around your neck. Insert end of vinyl tubing just inside the ear, then loop behind the ear where it will remain without falling out. If you prefer an earpiece, make one as shown (D).

A universal *transducer* may be constructed to fit any type headset without altering phones. Cut off a suitable length of radio spaghetti, and obtain 2 eyelet type rivets about $\frac{1}{2}$ in. long and with a dia. that will allow tubing to make a tight fit either inside or over the eyelet. In the center of a $1\frac{1}{8}$ sq. in. tire patch, pierce a hole, leaving the starched cloth backing in place. Next step in construction is to force an eye-

let into the hole, and then slip on tubing.

Slip a rubber radio grommet designed for a $\frac{1}{4}$ in. hole on the longer earpiece eyelet. Wind a narrow strip of Scotch tape over the flanged end of eyelet so grommet makes a tight fit. Finally attach the remaining end of tubing.

To attach to headphone, apply rubber cement to phone cap and allow it to set. Strip off cloth backing on tire patch and position over opening in earphone. It will remain attached indefinitely. Headphone set may be laid on a table, or hung around neck by headband spring. Rubber grommet makes a perfect little earpiece. A double set of transducers can be made, one for each phone, but volume is usually so good that a single unit is ample. Rubber grommet, eyelets, and vinyl tubing are stocked by all radio suppliers. Eyelets usually come in packages of assorted sizes. Leathercraft supply shops, harness shops

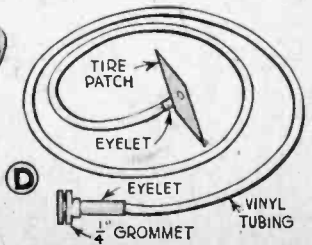
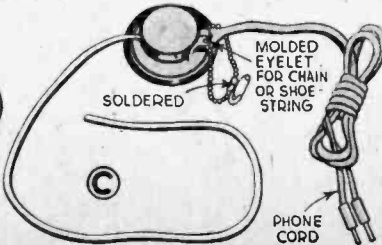
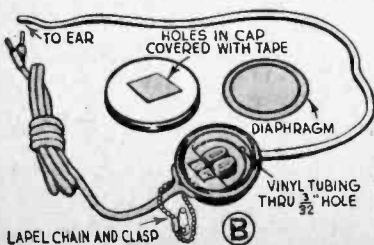

and hardware stores also have them.

Users of hearing aids may adopt this system with ease. Check dia. of opening in earpiece. Obtain a piece of clear tubing that will provide

a snug fit inside the earpiece. Tubing may be worn with or without rubber earbutton; place earphone in the shirt pocket. For continuous use, secure vinyl tubing behind ear with tape.

Trapping That TV Interference

When installed between your TV set and its antenna, these traps can often eliminate picture interference caused by autos, X-ray and diathermy machines

By THOMAS A. BLANCHARD

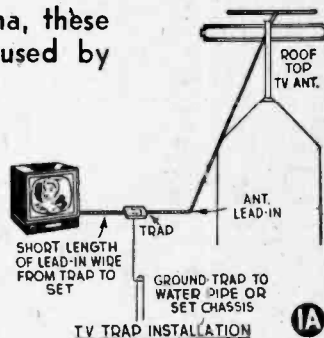
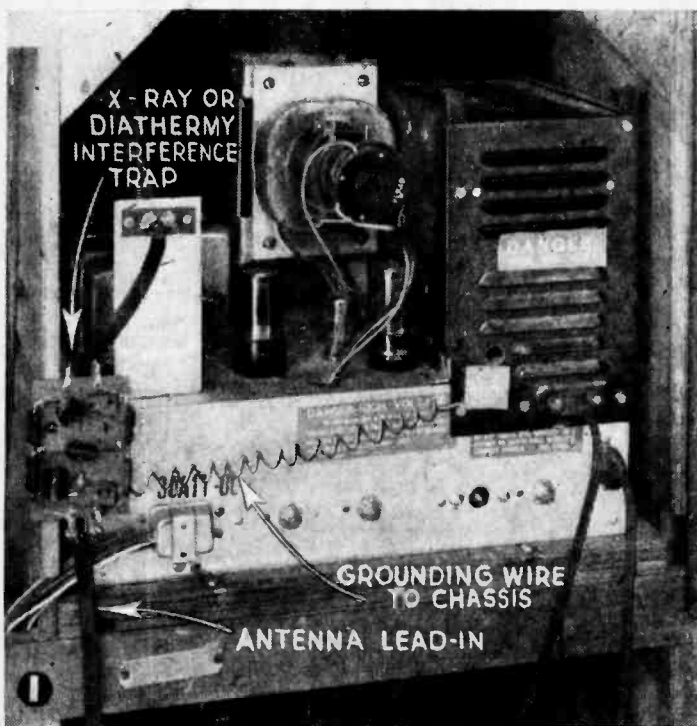

MATERIALS LIST

AUTO IGNITION TRAP (Figs. 2 and 2A)

- 2 50 mmf. ceramic or mica capacitors
- 1 homemade coil (L1) see text
- 1 Bakelite or fiber plate (1/16 x 1 3/4 x 2 in.)

X-RAY OR DIATHERMY TRAP (Figs. 1 and 3)

- C1 & C2—20 mmf. ceramic or mica capacitors (or 50 mmf. trimmers)
- C3, C4, C5, and C6—10 mmf. mica or ceramic capacitors
- L1, L2, and L3—homemade coils (see text). Coils must be mounted juxtaposed—each in an opposing position (see picture plan)
- 1 Fiber or bakelite plate: 1/16 x 3 x 2 1/4 in.

and two 50 mmf. ceramic type capacitors, mounted on a Bakelite or fiber plate 1/16 in. thick by 1 3/4 in. wide and 2 in.

long. Wind the coil (L1) of #20 enameled magnet wire on a wooden form 1/2 in. in diameter, with turns closely spaced. Scrape a small patch of enamel off the center turn with a razor blade and solder a short center-tapped ground connection at this point.

Use eyelets or small screws for junction points and connect the coil and 50 mmf. capacitors as shown in picture plan. Install the unit in your set by disconnecting the 300 ohm TV antenna and attaching the ignition trap between the TV set antenna binding posts and the outdoor lead-in. Ground the coil center-tap either to your TV set chassis or a convenient radiator or water pipe (Fig. 1). You can improve the ignition trap

NO ONE TV interference eliminator is a cure-all. Here are 2 completely different TV units, both installed between the set and the antenna to "trap" and return to the ground signals generated by auto ignitions, some neon signs, X-ray machines and diathermy equipment. Perhaps one of these will cure the particular interference trouble you've been having—if that TV power line interference filter presented on page 48 of this handbook doesn't do the job for you. That unit is intended to reduce or eliminate "hashed" pictures caused by electrical appliances.

The Ignition Trap (Figs. 2 and 2A) is extremely simple. It consists of a 10 turn inductance

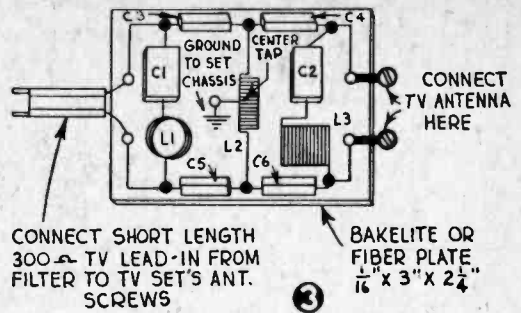
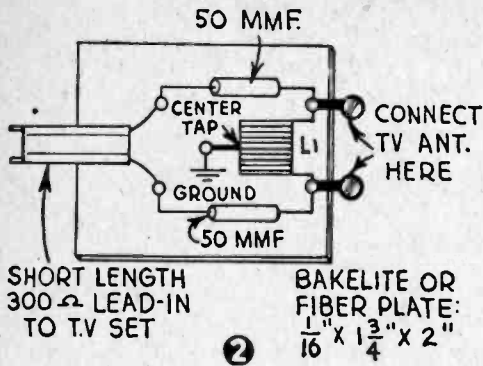

by connecting a mica trimmer capacitor across L1 coil so as to tune out some specific frequency. The trimmer should be a 50 mmf. size with the minimum value available—not more than 5 mmf. if possible.

The X-ray and diathermy filter (Figs. 1, 3, 3A) is just a more elaborate version of the ignition trap. But it should reduce or remove those horrible black smears running through the center of a TV picture that look so much like a fish after the cat has eaten off all the meat. For the X-ray filter, 3 coils and 6 capacitors are used. Components are mounted on a $\frac{1}{16} \times 1\frac{1}{4} \times 3$ in. fiber or Bakelite plate. The 3 coils are also wound of #20 enameled magnet wire. Coils L1 and L3 consist of 16 turns of wire on a $\frac{1}{2}$ in. dia. form. Forms used for all coils may be any material since they are removed after coil is made. Each coil assumes a self-supporting spring shape.

Coil L2 is of #20 wire but is wound on a $\frac{1}{4}$ in. form with 17 turns. Remove enameled insulation from the ends of all coils with a razor blade, as well as a bit from the center of the L2 for soldering on the ground tap. Capacitors C1 and C2 are 20 mmf. while C3, 4, 5 and 6 are 10 mmf. each. You may substitute two 50 mmf. mica trimmer capacitors for the C1 and C2 if you wish. The screw adjustment of the trimmer may permit some specific local interference to be tuned out precisely. A plastic or other non-metallic screw-driver should be used to prevent effects from body capacitance (a makeshift screwdriver can be whittled from a meat skewer

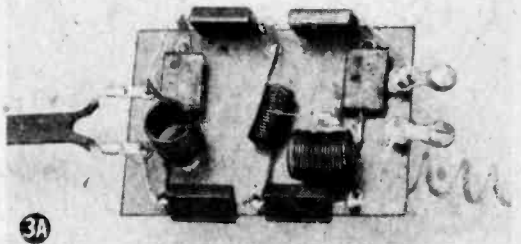

or $\frac{1}{4}$ in. wood dowel, if wood is thoroughly dry).

Although TV interference stems from many varied sources there is a better than even chance that one or more of these units will cure your trouble.

When You're Done With Those Cleaners

- Save the instruction booklet which comes with your TV or radio set. It may be needed for tube replacement or operating instructions. A cardboard pipe cleaner holder pasted to the back or bottom of the receiver will accommodate such booklets. Do not cover ventilating holes in the radio or TV cabinet.—H. LEEPER.



Iron Holder Makes Shop Accessory

- A discarded household iron holder will serve as a dual purpose radio servicing tool. Covering the top of the holder with asbestos paper equips it for holding the soldering iron as well as a handy container for the radio knobs and chassis screws for the set on which you are working.—H. LEEPER.

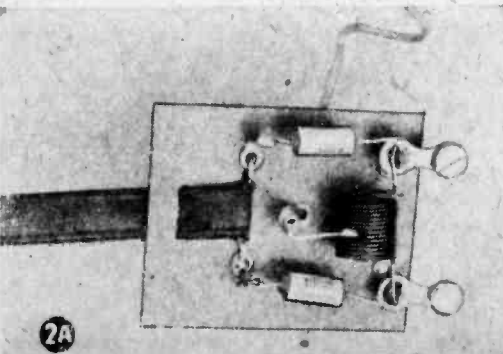

Pint-Sized Loudspeaker Radio Receiver

By T. A. BLANCHARD

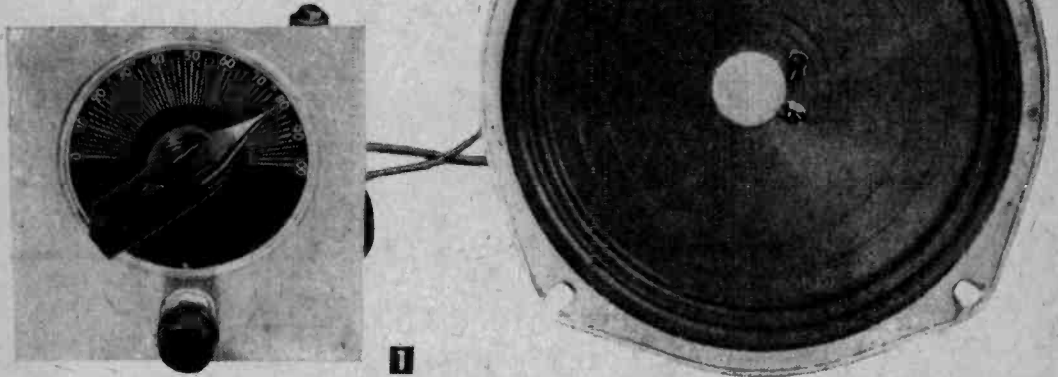

A dual purpose TV tube is the heart of this Lilliputian set which may be operated with headphones or speaker

Tiny set measuring 4x4 1/4 x 3 in. deep is dwarfed by small PM speaker it drives at more than normal volume.

ALTHOUGH this tiny radio operates on a single tube (plus rectifier), it has all the loudspeaker volume you'd expect from a much larger and complex receiver. The set is designed to operate any size PM speaker (even 12 in.) and may also be used as a personal set merely by inserting a headset in the rear chassis jacks instead of PM speaker and output transformer.

the set to operate directly off the power line without the use of a bulky step-down transformer.

The model shown uses a 25-watt Mazda lamp for the voltage dropping resistance. A 3-wire series plug connects the set to power outlet. When a 25-watt bulb is plugged into the top of

When you compare the finished receiver with the 6-in. PM speaker as shown in Fig. 1 you'll appreciate its minute size. Yet for all its miniature characteristics, there was no crowding of components on the chassis (Figs. 2 and 5).

Rear view of 1-tube loudspeaker set with its neat and simple top-side chassis components.

The dual triode tube employed is a 12AU7 widely used in TV sets. Half of the tube is the detector in a super-regenerative circuit, while its remaining triode section operates as an A.F. amplifier. The 12AU7 is a miniature tube with a 9-pin base. A miniature 35W4 half-wave rectifier tube supplies the set with the necessary d-c voltage. The heaters of the 12AU7 and 35W4 tubes are wired in series through a 500-ohm voltage dropping resistor, permitting

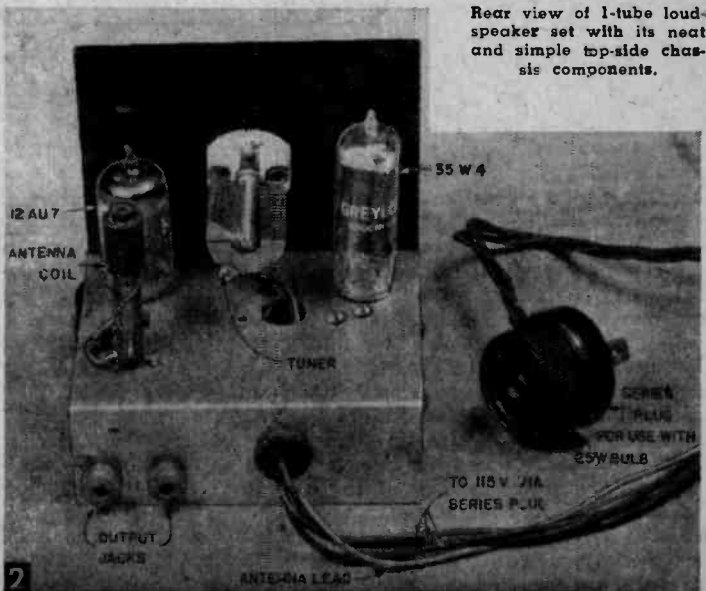

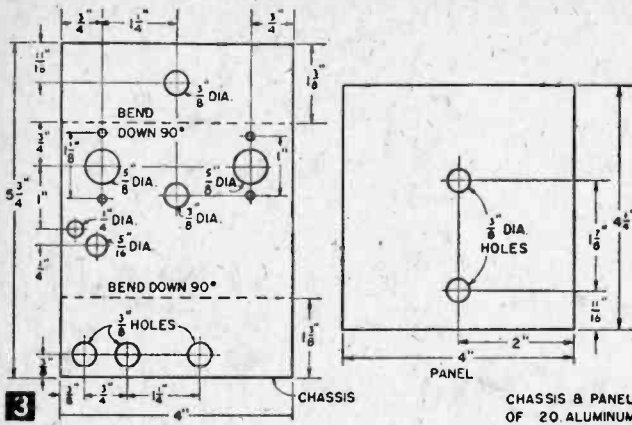

MATERIALS LIST—TINY LOUDSPEAKER RADIO

- 1 pc. #20 aluminum 4 x 5 3/4 in. for chassis
- 1 pc. #20 aluminum 4 x 4 1/4 in. for panel
- 1 dial plate and bar pointer knob
- 1 series tap (for use with 25-watt bulb)
- 1 7-pin miniature socket
- 1 9-pin miniature socket
- 1 pr. headphones or PM speaker
- 1 output transformer with 5000 ohm primary to voice coil (when operating set with speaker)
- 1 12AU7 tube
- 1 35W4 tube
- 1 antenna coil
- 2 phone tip jacks
- Misc. hardware, hook-up wire

RESISTORS

- 1 15-megohm, 1/2-watt resistor
- 1 27K (27,000) ohm, 1-watt resistor
- 1 1K (1000) ohm 2-watt resistor
- 1 480 or 500 ohm, 10 or 15-watt wire-wound resistor (or 25-watt Mazda lamp)
- 1 0.5-meg. volume control (potentiometer) with S.P.S.T. switch

CAPACITORS

- 1 5-50 mmf. trimmer
- 1 50 mmf. fixed mica or ceramic capacitor
- *1 .005 or .006 mfd. paper capacitor
- *1 tuning capacitor (approximately 360 mmf.)
- 1 20-20 mfd., 150 v. electrolytic capacitor
- *See text to determine value

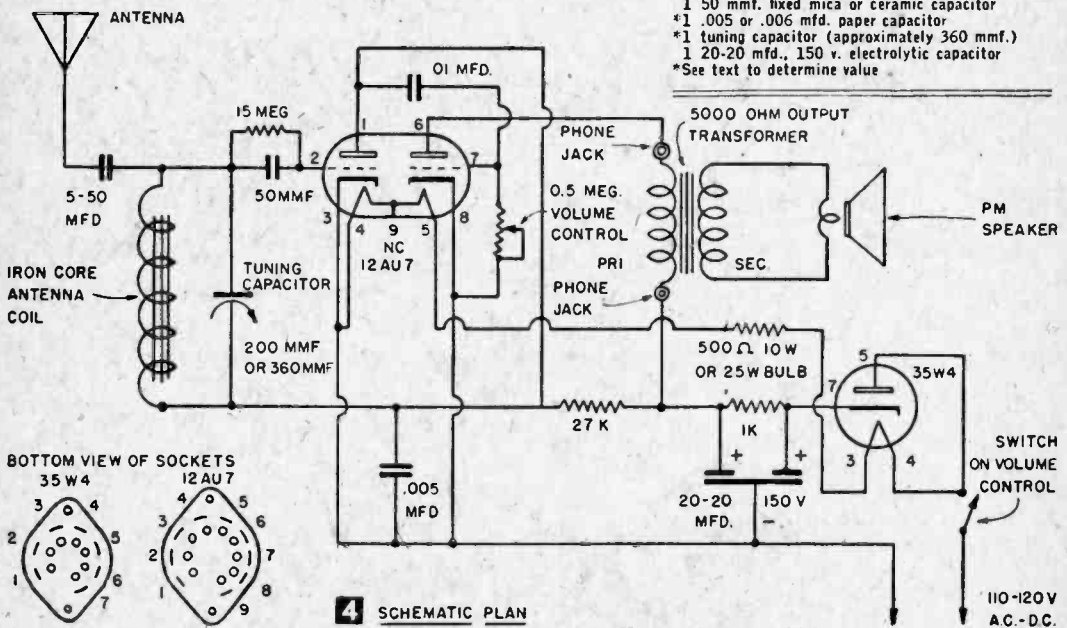

the series plug, the radio is ready for operation. A 10 to 25-watt wire-wound resistor may be mounted on the Mazda lamp arrangement.

Form the chassis and front panel from #20 aluminum (Fig. 3). Panel hole for variable tuning capacitor shaft may require changing to match capacitor used. Drill hole after securing capacitor and determine where it is to be mounted. After layout and hole-cutting operations are completed, bend chassis to shape. Note that chassis and front panel require no mounting screws since they are secured by the bushing of the volume control. Wire in components, following the simple schematic plan in Fig. 4, attaching antenna coil and front panel after all under-chassis work has been completed. The model shown uses a 140 mmf. miniature tuning capacitor. However, for complete broadcast band coverage, purchase a standard size 360 or 410

mmf. capacitor. There is ample room between tubes for the larger tuning capacitor.

When using a standard-size tuning capacitor it must, however, be mounted on Bakelite or fiber insulators so that both stator and rotor plates are insulated from chassis. Ordinarily, the rotor plates would ground to chassis. But in a super-regenerative circuit, the tuning capacitor is across grid and plate of the detector tube—not grid and ground as in the case of a regenerative or superhet circuit. Be careful, when mounting tuning capacitor, that the shaft does not contact metal where it passes through front panel.

The antenna is a ready-made component listed in most radio catalogs. Choose a coil listed as a high-Q, iron core or ferrite core type. These coils have either a bracket or snap-in chassis mounting and may be mounted accordingly. A short flexible lead is attached to antenna coil

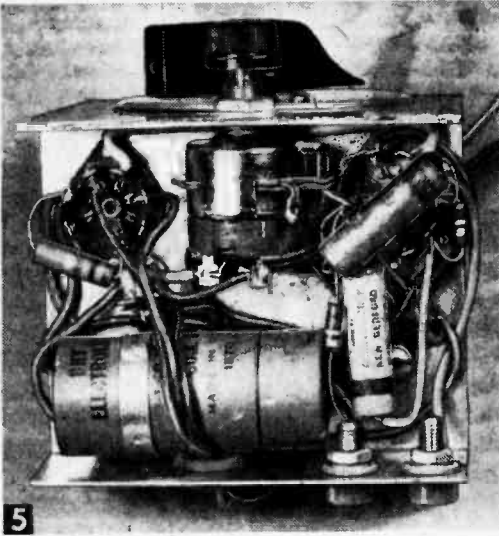

5 Bottom view of chassis with most space being occupied by the 20-20 mfd., 150 v. electrolytic capacitor. Chassis and panel are joined together by the threaded bushing of volume control.

through a 5-50 mmf. trimmer capacitor. The set requires very little antenna for good operation. A 2 or 3 ft. length of wire is ample for local broadcasting stations. The antenna lead may be attached to a metal object such as a bed-spring or window screen, for greater pick-up.

Vary the screw adjustment on the trimmer capacitor for best operation. If the set has a tendency to oscillate (whistle), replace the .005 mfd. capacitor with a .006 mfd. Proper adjustment of the antenna trimmer will also correct the over-sensitive tendencies of this circuit. It is always desirable to have a set of this type adjusted just within the point where it will oscillate for best reception.

If you wish, substitute two pieces of insulated hook-up wire for the 5-50 mmf. trimmer. Connect the bare end of one wire to a metal object. Now twist this lead and the wire coming from antenna coil together. The twisted insulated wires form a perfectly fine antenna coupling whose capacity is varied by more or less twist—two or three twists usually being sufficient. Greater coupling is achieved by additional twists of the insulated leads.

The metal chassis design used here is not absolutely necessary, as even cigar-box construction will provide good results, assuming wiring is correct. There is little or no "body capacity" effect so that metal chassis or shielding is not an important factor. It's not necessary to ground the chassis to power line through a capacitor to void body capacity effects on the circuit. You may, if you wish, attach a .1 mfd. capacitor from chassis to cathodes (pins 3 and 8) of the 12AU7 to bring the chassis to ground potential.

When tube filaments are operated in conjunc-

tion with a 25-watt Mazda lamp, the set's total power consumption is only about 10 watts. Once tubes have reached operating temperature, the Mazda lamp glows at a very low brilliance or about that of a 7-watt night bulb. When the set is first turned on, the 25-watt bulb burns at full intensity for a few seconds, then gradually dims until it has the full heater load across the filaments of the two tubes.

Simple Frequency Shifting

LESS time in changing frequencies sometimes means the gain or loss of a new radio contact in amateur radio. For the amateur using crystal controlled transmitters, here is a simple and inexpensive method of changing crystals by turning a switch. The project shown is for 5 crystals (or frequencies). The only other parts necessary are a 5-contact, single-gang switch and knob.

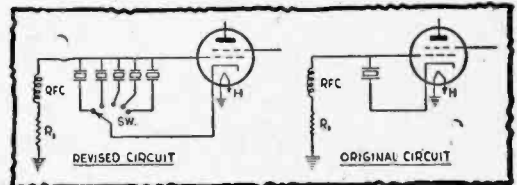

An etched switch plate with numerals 1 to 5 is optional.

Choose a position with at least 2 x 3 in. of space behind panel of transmitter as close to oscillator unit as possible. Lay crystals as close to oscillator unit as possible. Lay crystals on their sides against each other; then take a strip of friction or adhesive tape and wrap it around block of crystals. Crystals should be in the rectangular holders with two prongs protruding from the bottom. Solder a piece of #14 wire to one row of five prongs, to serve as a common ground. From each of the other prongs, connect a wire to each of the 5 terminals on the outside row of single-gang switch. A wire from the center of the switch serves as the hot or positive lead to the grid of your oscillator tube. By merely turning the switch, you can change from one frequency to another.

If more or fewer than 5 frequencies, or crystals, are desired, use a single-gang switch with desired number of terminals on it. These few parts, less crystals, cost about 80 cents. The #14 wire is strong enough to support five crystals so they may hang directly under the switch on the panel of your transmitter. A single-gang switch, etched switch plate, and pointer knob are obtainable in any wholesale or radio parts store, or from most radio servicemen.—A. M. GENT.

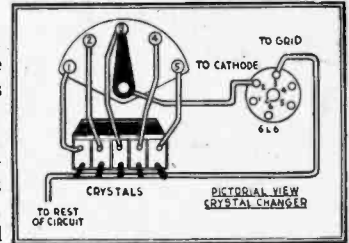

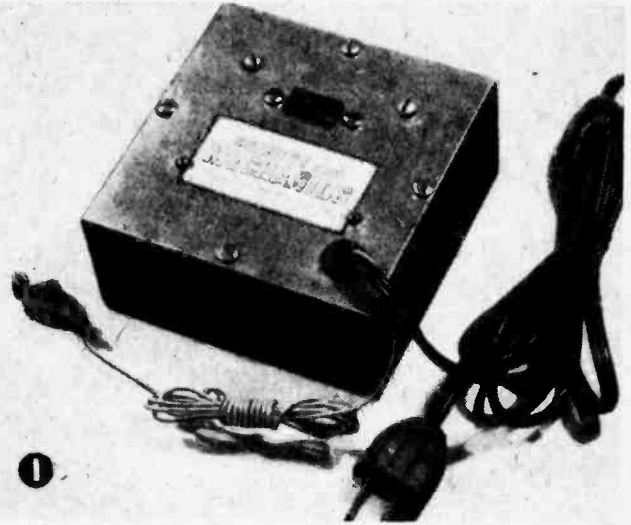
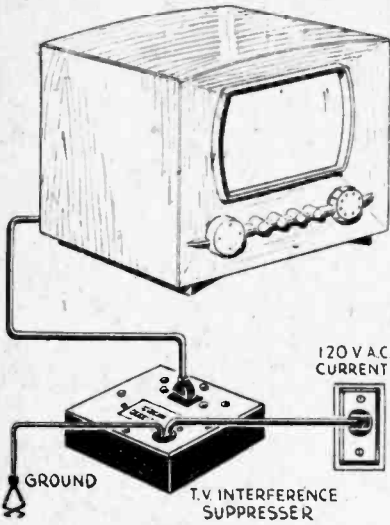

TV Interference Suppressor

Eliminate or greatly reduce those annoying streaks from your television pictures with this compact interference filter device

By THOMAS A. BLANCHARD

BECAUSE our ears adjust readily to extraneous noises, normal clicks, or man-made static in regular radio reception, these are hardly noticed except where a continuous racket is set up by an electric shaver, vacuum cleaner, or other brush or universal type motors. On your

TV set this interference comes as a harsh series of streaks on the TV picture, rather than as an audible sound. Where the interference is unusually severe, the picture-lock (sync.) circuit is also affected and the picture synchronization is lost, causing a rolling picture.

This simple filter (Fig. 1), when connected between the TV set and its outlet may completely cure your line interference troubles if they are mild or moderate. In severe cases, you'll

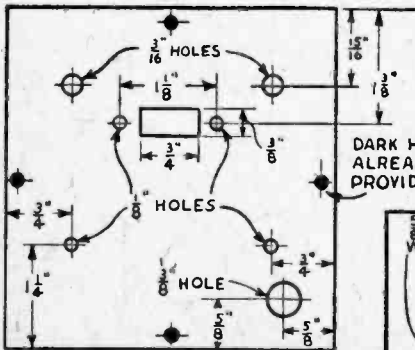

PANEL LAYOUT FOR 4"x4"x2" RADIO BOX

PICTORIAL PLAN

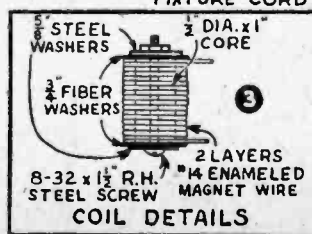
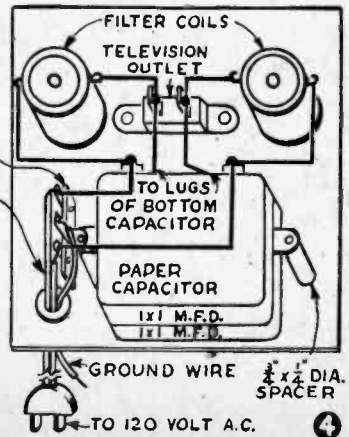

3

4

MATERIALS LIST—TV INTERFERENCE SUPPRESSER

- 4 washers: 2, 3/4" dia. fiber; 2, 3/8" dia. steel
- 6 machine screws & nuts: 2, 1/4" x 6-32; 2, 1 1/2" x 8-32; 2, 1" x 6-32
- 1 radio utility type metal box, 4" x 4" x 2"
- 1 6 ft. appliance cord (rubber or plastic)
- 1 3-lug (center ground) terminal strip
- 1 female outlet; NA-ALD ±4002, SNAPIT fluorescent type, or AMPHENOL Type 61-F female AC receptacle
- 2 1 x 1, .25 x .25, or .5 x .5 mfd. "bathtub" type capacitors, rated 200 to 600 DC w.v. (Mallory, Aerovox, Sprague, C.D., etc.)
- 15 ft. #12 or #14 enameled magnet wire (as used for radio antenna purposes)
- 2 ft. #12 or #14 solid vinyl-insulated electrical wire
- 6 ft. insulated ground lead (any flexible plastic or rubber-covered wire)
- 1 small battery clip for above, or ground clamp
- 1 LITTLEFUSE or BUSS fuse clip or extra-actor post and 2 to 5 amp. fuse (optional—see text)
- 1 3/8 in. rubber grommet
- 2 1/2 x 1 in. powdered iron cores (see text)

Suitable cores may be obtained at 25c each from E. G. Little, Mrs., Springdale, Connecticut.

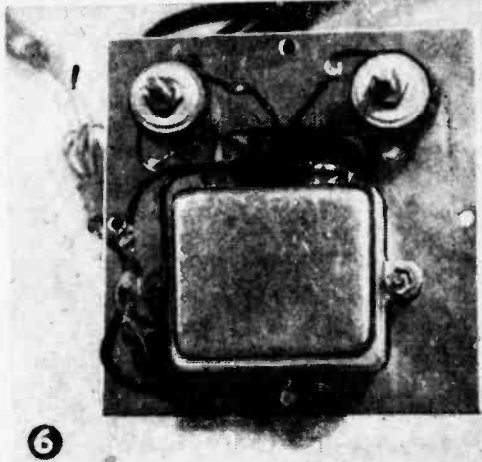

see at least 50 per cent improvement. While intended to alleviate power line disturbances, it was discovered during experiments that this filter also "killed" auto ignition effects which we always had assumed were being picked up by the TV antenna. It was found that automobiles ceased to cause picture trouble after passing an intersection where the utility line made a right-angle turn off the highway. While some ignition interference was being picked up by the receiving antenna, most of it seemed to be transmitted via the power line. With the filter attached, this fact was proved.

Except for the filter's coils, all components required to construct this device are available from any radio parts house. Mount filter components on the panel of a 4x4x2 in. radio metal utility cabinet which has formed sides and a removable top and bottom. Remove one plate from the metal box, and lay out mounting holes (Fig. 2). Use either the Na-ald No. 4002 receptacle here, which requires a 3/4x3/8 in. rectangular slot, or a similar type sold by electric supply houses and used in many bathroom light fixtures. Or you can use the Amphenol Type 61-F 110 volt female receptacle, obtainable at radio dealers, which mounts in a 1 1/8 in. round

hole with a retainer ring. To make slot, drill a series of holes, break out the mid-section, and file edges smooth in a vise.

The coils are extremely small compared to more conventional choke coils. Since the windings are on powdered iron or sintered metal cores, they require fewer turns than "air-core" coils. You probably will find inexpensive powdered iron cores at surplus shops, some radio and electrical dealers, or at General Electric Supply, Westinghouse Supply, or Graybar Electric in any of the larger cities. If the core material is available in solid form, cut off two 1-in. lengths, then drill a 3/16" hole through the center of each 1/2 in. dia. core to pass an 8-32x1 1/2 in. rh (round-head) machine screw (Fig. 3). The sintered metal rod, a little harder than the carbon found in dry cells, drills and cuts easily; therefore be careful not to exert too much pressure or it will split or chip.

With cores completed, slip a 5/8 in. iron washer on each 8-32 screw, then a 3/4 in. fiber washer. Slip core on the bolt, then another fiber washer and iron washer, and draw resulting bobbin together with the 8-32 nut. Cover core with Scotch masking or electric tape for insulation purposes, or with a strip of brown wrapping paper (Kraft type) doped with shellac to make it stick. Start-

ing from the nut end, wind 2 even layers of #12 or #14 enameled, magnet wire on the core.

Because #12 wire is very stiff and won't unravel easily, you can wind the 2 layers on the core without trouble. Wind one layer down, then wind the second layer up over the first. Tie start and finish ends of wire with twine, and finally cover coils with Scotch or friction tape.

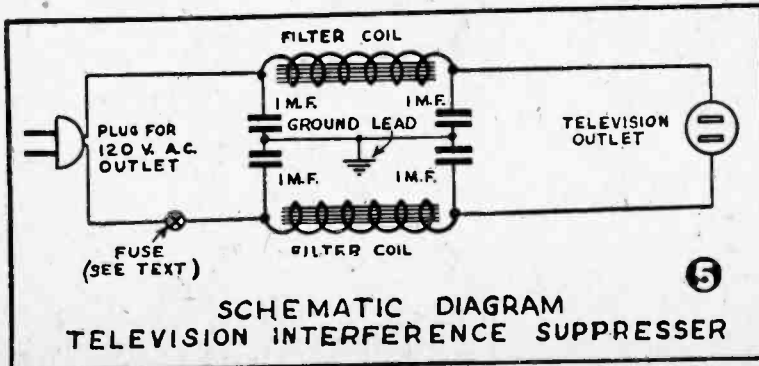

**SCHEMATIC DIAGRAM
TELEVISION INTERFERENCE SUPPRESSER**

Strip ends of the coils of insulation and bend into small loops for convenient soldering connections.

The paper or "bathtub" type capacitors (Fig. 4) each contain two 1 mfd. units, with one side of each internally grounded to the metal can. In some instances the dual units may have 3 lugs—the ground being brought out to the center one. In such instances, continue ground clip lead from center lug of 3-lug terminal strip over to center lugs of the 2 "bathtub" capacitors. While 1x1 mfd. units are preferred, you can substitute .25x.25 or .5x.5 mfd. capacitors, rated anywhere from 200 dc working volts to 600.

Place capacitor units back to back and mount to panel with $\frac{3}{4}$ in. long spacers and 1 in., 6-32 machine screws. If ready-made spacers aren't available, make them from copper or steel auto "gas-line" tubing cut into $\frac{3}{4}$ in. lengths. Remove screws from coils and mount these on the box panel, replacing washers in original position. After inserting a rubber grommet in the $\frac{3}{8}$ in. panel hole, and mounting 3-lug radio terminal strip under one of the capacitor mounting screws, the filter is ready for wiring (Fig. 5).

If possible, use # 14 solid vinyl-covered wire to permit filter to handle loads up to 2000 watts—far in excess of the average requirements. Where trouble is caused by a particular appliance, filter can be permanently installed at the source of the trouble, thus not only eliminating

television interference in your own home but in your neighbors' as well. Some oil burners, stokers, electric ranges, etc., are sufficiently annoying to warrant a separate filter on the device itself. However, in such instances, use industrial cord suitable for the particular load.

The completed filter (Fig. 6) will fit snugly into the 4x4x2 in. metal box. The grounding lead should be long enough to permit attachment to a water pipe or steam-hot water radiator. Don't attach TV set and filter to 110 volt line until the ground wire has been attached securely. The four 1 mfd. units accumulate quite a charge which results in a large flash as the ground lead contacts the water pipe—also a shock! Likewise, when filter plug is removed from 110 volt outlet, a shock may result if plug prongs are touched even though unit is completely disconnected. The capacitors will hold a charge for several minutes so prongs should be shorted with an insulated screwdriver when disconnecting the unit.

As an extra feature, you may add a line fuse (of the "Extractor Post" variety) into the filter unit, thus giving the set the safety feature included in only the most expensive types of television sets. Use a Buss or Littlefuse rated from 2 to 5 amps., depending on the set size and per the power consumption data found on the receiver's nameplate or in the instruction manual. Insert fuse post at "X" in schematic plan (Fig. 5).

Flashlight Makes Continuity Tester

By WESLEY J. REDEIR

A LOW voltage continuity tester that can be used to check radio circuits, electrical appliances and other electrical apparatus, can be easily constructed as follows:

Drill a $\frac{5}{16}$ inch hole in the bottom center of the flashlight cap. Remove the spring from the cap and line the bottom and lower sides of the cap with several layers of cloth or strong paper. Now replace the spring, making certain that the cloth or paper fully insulates the spring from the cap.

Punch a hole through this insulation, in line with the hole in the cap. Strip about $\frac{1}{2}$ inch of insulation from one test lead and string this end through the hole and solder to the spring. One end of the other lead is also stripped and soldered to the outside of the metal cap, as indicated. Fit an insulating sleeve into the hole to protect the lead. If none is available, tape may be substituted; this should be wrapped around the lead where the lead enters the cap. The free ends of the leads can now be fitted with the conventional

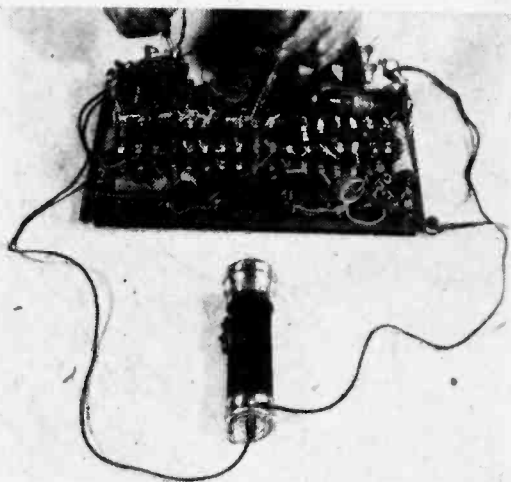
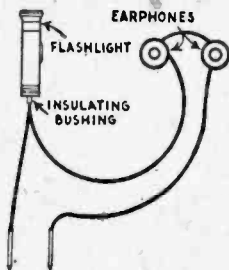

MATERIAL REQUIRED

- 2 Test leads. Should be about 2 feet long, of #16 or #18 flexible rubber covered wire
- 2 Test prods
- 1 Insulating sleeve, or piece of friction tape
- 1 Set of earphones (optional)

type of test prods. These can be bought at any radio parts store.

To use, turn on the flashlight switch; the bulb should now light when the prods are touched

together. If the resistance of the circuit to be tested is too high to light the bulb, a set of ear-phones can be connected in series with the light, as shown in drawing. A distinctive click will be heard when the circuit is closed.

If a spare cap is available (many are interchangeable), the flashlight will serve a dual purpose, it being only necessary to switch caps to use either as a tester or a flashlight, which gives you a more versatile unit.

3-in-1 TV Control

By THOMAS A. BLANCHARD

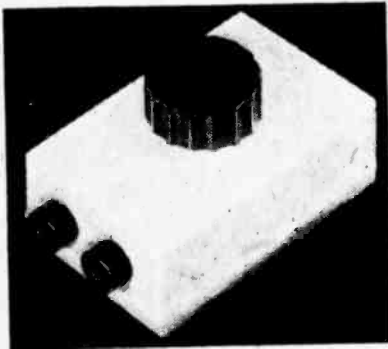

Fig. 2. Control built into small plastic box which used to house a small safety razor.

TV SET owners with children have a universal complaint: "The noise of those cowboy movies drives us crazy!" But try to pry the youngsters away with a crowbar—it can't be done! This attachment (Fig. 1) for any make or size TV set not only allows the kids to listen without disturbing you, but also permits you to either increase or decrease the set's volume by remote control from your easy chair. And if there is a member of the family who is hard-of-hearing, he can enjoy the program with you without blasting others out of the house.

You need no radio or TV knowledge to construct this control, nor will you be involved with any high voltages or internal wiring, since the point of connection is to one of the speaker wires. The control consists of a small plastic or wooden box just large enough to contain 2 earphone tip jacks and a 2000 ohm potentiometer (volume control). The plastic box shown here (Fig. 2) was designed to hold a safety razor and measures $1\frac{3}{4} \times 2\frac{3}{4} \times 1\frac{1}{8}$ in. deep.

In the center of the bottom of box we drilled a $\frac{1}{4}$ in. hole, then reamed it out to $\frac{3}{8}$ in. to accept the potentiometer. Two $\frac{1}{4}$ in. holes were drilled in the end of the box to accept 2 earphone tip-jacks (Figs. 3 and 4). A single $\frac{1}{4}$ in. hole was drilled in the opposite end of box for

Fig. 1. Below, a pair of standard 2,000 ohm headphones plugged into this control, and only you or the youngster can hear that noisy TV show.

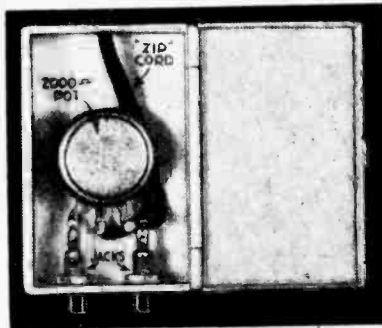
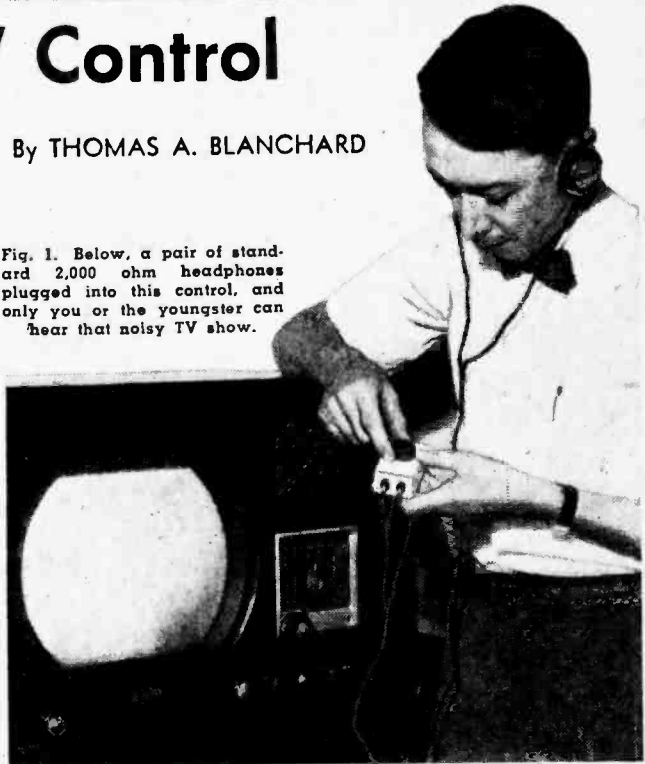

Fig. 3. Unit contains 2000 ohm volume control (center) and 2 phone tip jacks. When used as a remote control, phones are disconnected from unit.

passage of the connecting cord. This cord is a suitable length of ordinary plastic or rubber fixture wire known as "zip-cord."

When the control is merely for ear-phone use, this cord need not be more than a couple of feet long. If, however, the control is used without the ear-phones for remote volume regulation, a length of 300 ohm TV

lead-in wire may be used instead of "zip-cord." The lead-in wire, being flat, may be laid under a rug without causing a bulge.

With components mounted in the box, wire them according to Fig. 4. Note that there are only 5 soldered connections in the box. To connect the control permanently to the TV set, remove back cover (if any) and locate the 2, 3, or

MATERIALS LIST: TV CONTROL

- 1 small plastic or wooden box (see text)
- 2 earphone tip jacks (American Radio Hardware, etc.)
- 1 suitable length fixture "zip" cord, or 300 ohm TV lead-in wire
- 1 2000 ohm IRC, Mallory, or Ohmite-Bradley potentiometer
- 1 plastic knob for potentiometer (set-screw type)
- 1 pair 2000 ohm headphones (two youngsters may listen by removing 1 phone from headband)

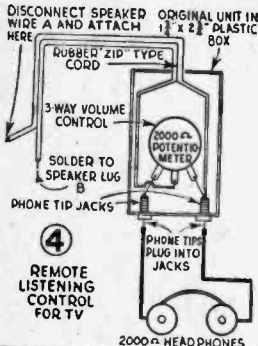

4-wire cable from set to speaker. Most TV sets employ the revived electro-dynamic type speaker which hasn't been seen on radio sets for more than 10 years. The field coil of the dynamic serves as the low voltage filter choke and thus saves space on the TV chassis.

Inspect the speaker carefully and note that the speaker cable terminates at the center core as well as at 2 soldering lugs leading from the speaker cone

(paper diaphragm). One of the cone lugs connects back to the center core (field) winding. With a soldering iron, disconnect the cable wire which connects directly and *only* to the voice coil diaphragm lug. This wire is often *white*.

The remote control is then attached by connecting one of its wires to the speaker lug. The other control wire is connected to the disconnected cable wire, and taped. In simple terms, the control has been connected in series with the voice coil of your TV speaker. If more convenient, the control may be installed at a more accessible point simply by noting the color of the voice coil lead, and inserting it in series with, let's say, the white wire near speaker plug.

To adjust the volume control, turn the control knob to the extreme left, making sure earphone volume off and speaker is on full. Then advancing knob to the right will reduce speaker volume and gradually build up the earphone volume. At a point about $\frac{1}{3}$ from left, speaker and phones will receive equal sound. To use the control for earphone reception only, turn knob all the way to right and regulate volume with the usual control on set. Also, remember to adjust the set's volume control to the desired level when using the accessory only as a remote volume regulator. The unit will then never increase volume beyond the point at which the TV set is adjusted.

The TV set should not be turned on full volume because "sound bars" may appear. This is a normal condition caused by overloading and happens on strong TV stations with or without the use of this adapter.

Build a Turntable For Your TV Receiver



• To get more use from your table model TV set, try this turntable designed by Richard Heid of West Allis, Wis. Get an old automobile generator bearing ($\frac{1}{2}$ in. wide, $1\frac{1}{2}$ in. O.D., $\frac{5}{8}$ in I.D.) an old phonograph turntable, 4 suction cups, four $\frac{1}{2}$ in. screws, and 2 pieces of $\frac{5}{8}$ in. wood, same size as bottom of set. Countersink bearing in center of one piece of wood; on opposite side place suction cups 2 in. from corners. Grind down center rod of

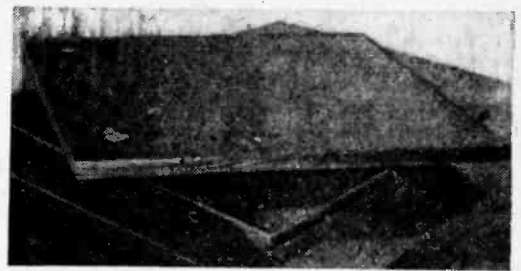
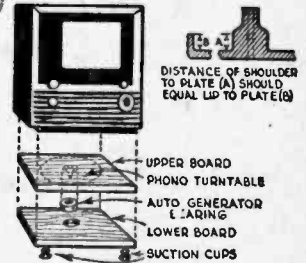

turntable to a press fit into bearing ($\frac{5}{8}$ in.), leaving a slight shoulder about the same distance from turntable as lip at its rim. Drill 4 holes in turntable and fasten it to top board with $\frac{1}{2}$ in. screws.

Place board with suction cups where you want your TV set to be; insert rod into bearing, and place set on board top. If you ground down too much shoulder, soap lower board where rim hits and it will work. Finish wood to match set and your television turntable is then complete.—LYMAN LINDAS.

Wireless Radio Intercom Converter

Install this unit in any 4, 5, or 6-tube superhet type radio, to give you 2-way wireless communication

By T. A. BLANCHARD

If you decided against installing a 2-way intercom system in your home, office, store, farm or factory, because a 2-unit commercial set would cost around \$80, the attachment described in this article is for you. With it you can convert a 5-tube set (which will probably cost less than \$15) to an intercom (Fig. 1) for less than \$2.50. Thus you can have a complete outfit (including radios) for approximately \$35. And a flick of the switch will change the set from an intercom transmitter to a radio receiver, as well as vice versa.

While two radios equipped with the intercom attachment allow two-way conversation, a single set is excellent for keeping tabs on youngsters playing or sleeping in some other part of the house. A busy mother can do the laundry in the basement without missing phone calls, delivery men or callers, with all upstairs noises being magically relayed downstairs via the intercom.

The set's speaker becomes a dynamic micro-

Small radio with intercom unit installed above tuning dial. Attachment permits operation as transmitter and receiver.

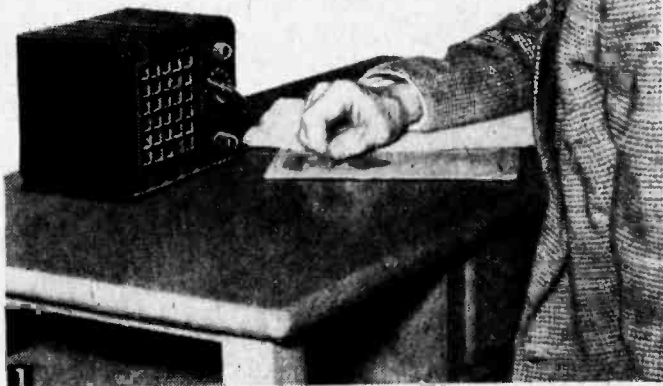

phone which is connected through the switching circuit into the two audio amplifier stages of the receiver (Fig. 3). The amplified signal is then fed to the screen grid of the set's oscillator, producing a modulated signal which can be received on any other set in the home. As the intercom unit is extremely compact, it can be installed inside most any radio cabinet simply by drilling a $\frac{3}{8}$ -in. hole for the threaded switch mounting.

For the unit illustrated here, we used a $2\frac{1}{2}$ x $1\frac{1}{4}$ -in. aluminum panel, drilling a $\frac{3}{8}$ in. hole in the center for the switch, and two $\frac{1}{8}$ in. holes spaced 2 in. apart for mounting the transformer (Fig. 2). After securing switch to panel, the transformer is mounted over it on $\frac{1}{4}$ in. dia. x $\frac{3}{4}$ in. metal spacers with 1 in., 4-40 machine screws.

Because of mechanical variations in components, make the panel only after switch and transformer are on hand, as spacing of transformer mounting ears and switch diameter and height may vary from original model shown here. Wire the intercom attachment according to the pictorial plan (Fig. 3).

To avoid confusion in connecting the switch, mark your switch contacts and arms in pencil corresponding to plan numbering. R denotes switch in radio receiver position; T denotes



Close-up of intercom unit. Switch in R position for listening; turned to T for talking.

MATERIALS LIST—RADIO INTERCOM

- 1 pc. #16 or 18 gage aluminum, 2½ x 13¼"
- 2 metal spacers; ¼" dia. x ¾" long
- 2 machine screws, 1" x 4-40 with nuts to match
- 1 midget interstage audio transformer, 3:1 or 2:1 ratio (Thordarson #T13A34) from any radio supply house
- 1 selector switch, 4-poles, 2-position (Mallory or Centralab) from radio supply house
- 1 bar knob for switch
- 8 ft. plastic stranded radio hook-up wire

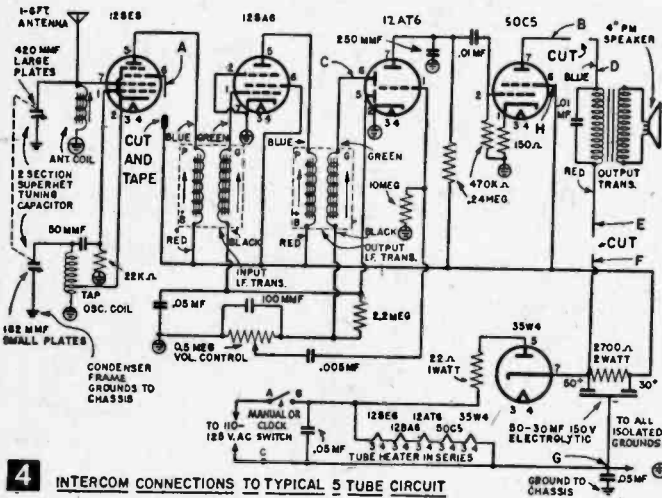
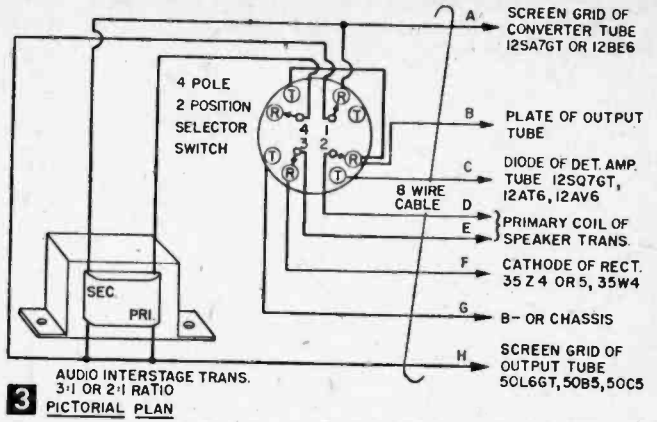
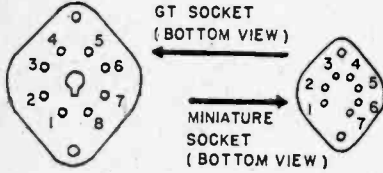

of 50L6GT output tube, or lug #7 of 50C5 miniature, or lug #5 of 50B5 miniature. Connect this wire (one side of speaker transformer primary) to cable wire D. Now connect cable wire B to the vacated socket lug.

3. Disconnect the remaining speaker transformer wire (only) from the cathode lug of rectifier tube or whatever point it is soldered. Now solder cable wire F to this point, and the free speaker transformer lead to wire E.

4. Connect cable wire C to the input diode of the detector-amplifier tube. The wire now on diode lug #4 of the 12SQ7GT or lug #6 of the miniature 12AT6 or 12AV6 is not disturbed; merely add cable wire C.

switch in radio talk position. Note that there is no connection to T in 1st switch section; no connection to R in 4th switch section.

Connect intercom unit to set with a cable made up of 8 pieces of stranded radio hook-up wire about 10 in. long (Fig. 4). These wires may be a bit longer or shorter depending upon the particular radio involved. Before lacing or taping the cable wires together, tag the ends with small adhesive tape bands marked A to H as shown (Fig. 3) to prevent wiring errors.

With set removed from cabinet, wire in the intercom unit as follows:

1. Remove, permanently, wire on screen-grid socket lug #4 of 12SA7GT converter tube, or from lug #6 of miniature 12BE6 converter. Connect cable wire A to vacated socket lug. Tape end of loose wire.
2. Remove wire from plate lug #3

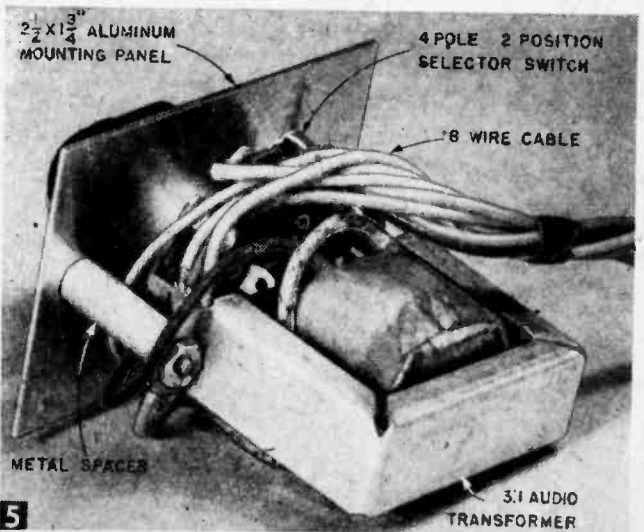

Intercom attachment forms a rigid assembly with 8-wire cable providing quick hook-up to radio.

5. Connect cable wire G to the set chassis if it is a set with all B-connections soldered directly to the metal. If set is wired with B-isolated, connect G to point where black wire from large electrolytic filter capacitor is soldered.

6. Connect cable wire H to screen-grid lug of output tube. Do not remove any wires already connected to this lug. If tube is a 50L6GT, connect cable wire H to lug #4. If tube is miniature 50C5, connect to lug #6. If it is miniature 50B5, connect to lug #6.

If, where removal of a wire from a socket lug is specified, more than one wire is found to be soldered to a specific lug, remove all wires, twist together, solder and tape ends.

With connections made, replace set in cabinet, and mount intercom unit in $\frac{3}{8}$ -in. hole drilled in cabinet. To use for wireless transmission of voice, set intercom switch to talk position.

Tune another radio to a quiet spot near the high end of the dial, 1600 kc, or as high as set will tune. After allowing for the usual warm-up, slowly tune the dial on the intercom-equipped radio until its carrier signal is heard through the

other set. Start from the high end of the band and tune down. The carrier is easily recognized by its purring sound.

When you are sharply tuned on this carrier, talk into the speaker of the intercom set, and you'll hear your voice coming from the set in an adjacent room. Never attempt to test the units in the same room because oscillations set up between the intercom speaker and radio speaker produce a terrible howl known as *feedback*.

While the intercom signal will be picked up by the radio at several points across the intercom dial, all other signals are harmonics except that one picked up when intercom is tuned to the frequency nearest the setting of the radio dial. To reverse the talking direction in a two-way system, repeat the tuning procedure using the other radio with its intercom switch on T (talk). Close tuning will be required.

To extend the range or strength of signal, try reversing line cord plug in outlet. A wire attached to the outside antenna binding post screw on the set, may be attached to water pipe or other metal objects to increase operating range.

Micro-Switch Telegraph Sounder

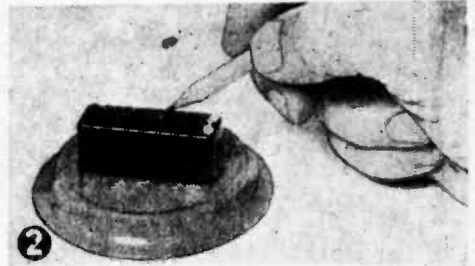
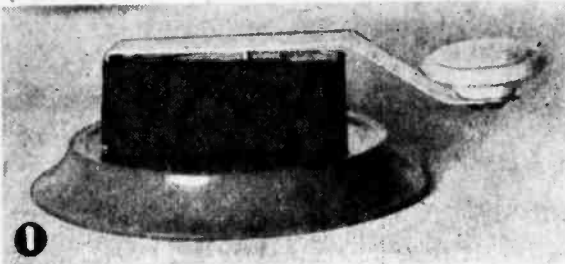

IF YOU send code by pressing the pin of a micro-switch (Fig. 2) as you would press the knob of a transmitting key, you'll note that it sounds like a Western Union telegraph sounder. Using this fact, you can make a simple combination sounder and key from a micro-switch, and a dime store plastic coaster, to use when practicing telegraph code.

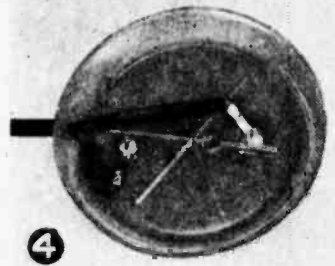
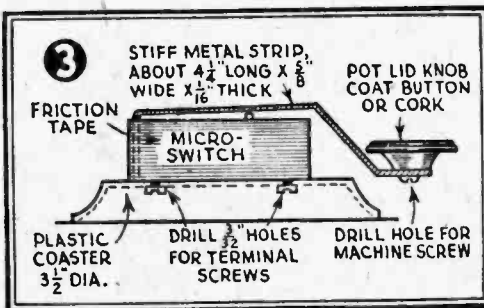

To make the instrument, mount micro-switch on bottom side of plastic coaster with 2 terminal screws on switch bottom. Coaster serves as a base for sounder and key and as an effective sounding-board to make clicks louder. To make a lever for switch, cut a strip of stiff metal about $4\frac{1}{4}$ in. long x $\frac{5}{8}$ in. wide, and bend as shown

(Figs. 1 and 3). Tape bent strip securely to rear of switch by winding 3 or 4 turns of electrical tape tightly all around switch. Knob for lever can be a pot lid knob, coat button, or a cork.

You can also use this device as a radio code practicing key by making wire connections to terminal screws on bottom of switch for a buzzer and a battery (Fig. 4). To do this, drill a $\frac{1}{4}$ in. dia. hole through side of coaster as passage for wires.—ARTHUR TRAUFFER.

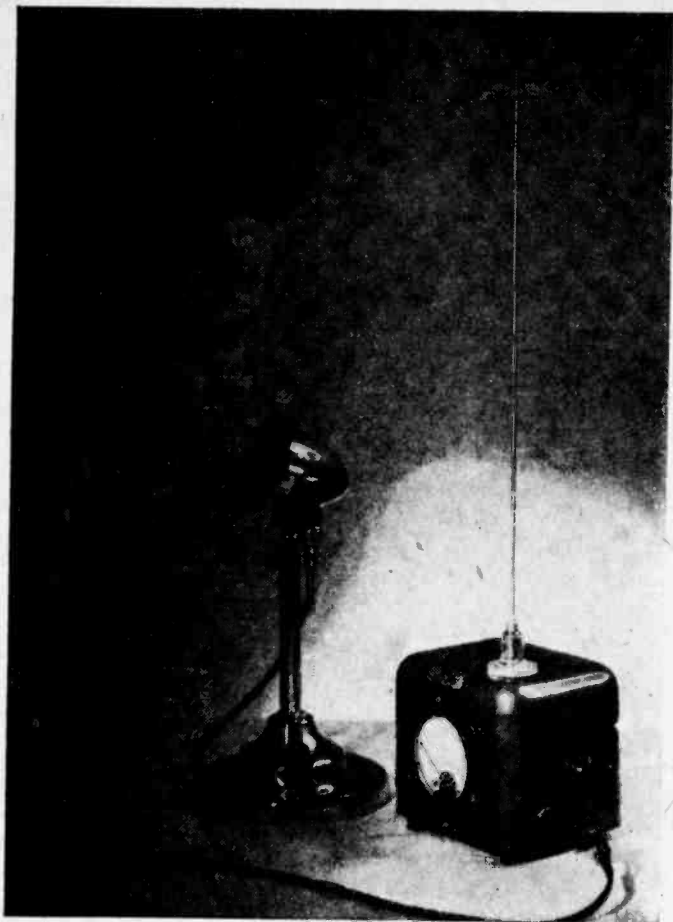

Versatile Radio Frequency Indicator

This portable testing unit is a handy helper for radio technicians and amateurs

By ALVA R. WILSON

HERE is one of the most versatile, useful, and easy-to-build test units to be offered to the post war radio technician and amateur. It is especially well adapted for working with either FM or AM transmitters and/or antennas and on any wave length ranging from the lowest to the ultra high frequency types. Stage by stage alignment procedure may be accurately followed, starting at the oscillator and following through each stage step by step to the final power amplifier, and on to the antenna and its tuning adjustments for maximum output. It can

hour's time is all that is required for its construction.

This unit was built into a "station" box from an intercommunications system. A 3 in. speaker originally contained in the box was removed and this left a hole the correct size for a 3 in. meter. Removing the push button which was on top left a hole for the polystyrene feed through insulator. To complete the case, two holes were bored for the tuning condenser and volume control. There is ample room in the sloping front panel meter boxes, for sale in any radio store, for hous-

Materials List

Radio Frequency Indicator

Antenna (Car roof antenna modified as described in text)

2½ mh. 4 layer type r.f. choke

50 mmfd. variable condenser

100 mmfd. fixed condenser

250 mmfd. fixed condenser

10,000 ohm. volume control

Phone Jack (closed circuit type)

1N34 Diode

also be used as a check for the field strength of directional types of antennas that have single or multiple units which need accurate tuning for maximum results.

Because it can be easily moved to the unit to be serviced, this testing unit is especially useful for servicing mobile equipment such as the latest types of two way communications equipment of the ultra high frequency type (160 megacycle FM) used by some taxicab companies, two way police short wave and similar equipment of the intermediate frequencies (7 meters). Since it is self contained and easily fits the hand, it has been in demand in more parts of our servicing shop than any other piece of test equipment at our disposal. For instance, the receiver service man grabs it and sticks the probe (the antenna) near the oscillator coil of a broadcast receiver to check it for radio frequency output; an amateur transmitter is being tuned up for a Q S O or a demonstration and the operator gets the test unit from the broadcast serviceman and sets it on the desk, plugs in a pair of headphones, and listens to the carrier and then to the voice quality of the transmitter. He also watches the meter for percentage of modulation and carrier shift indications. With all its versatility, this handy instrument is so simple that an

ing this unit. Or any small box available may be used, in case you do not have a spare speaker case lying around. The rest of the components you will need are specified in the materials list. The feed-through insulator used was a polystyrene type with a metal bushing feeding through both halves and threaded at each end for $\frac{3}{32}$ in. machine screws. A low loss material such as steatite, polystyrene, alsmag or porcelain must be used here as hard fiber; Bakelite, rubber or glass ordinarily used at lower frequencies are practically useless at the higher frequencies in-

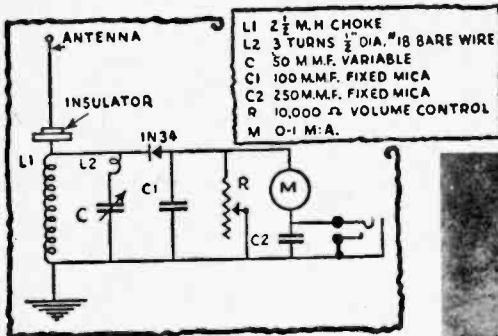

involved in the aforementioned uses to which this unit is put.

The antenna used was the top section of a 15 1/2 in. long Ford roof antenna. We threaded the lower end and screwed it into the top of the metal sleeve that ran through the insulator. If you do not have the proper size die handy, drill a hole in the top of an $\frac{3}{32}$ in. machine screw, grind antenna end to fit it and solder it in the screw head. The tuning condenser used was of the type having a threaded mounting bushing on one end of the shaft and was mounted in hole bored in side of case directly below antenna lead-in insulator. Since the one nut furnishes a radio frequency ground as well as a support for the condenser, paint must be cleaned from around sides of hole on inside of metal container where shoulder around tuning condenser shaft will come into contact with the metal, and outside mounting nut must be tightened firmly so as to make this contact perfect, as this is the common ground used for the entire instrument. Solder all other ground returns to ground lug on condenser frame. Next mount 3 soldering lugs under a $\frac{3}{32}$ in. screw and screw it into the underside of the feed through insulator bushing. To one lug solder a 2 1/2 mh r.f. choke of the 4-layer type; return the other end to the common ground. To second lug connect a 3-turn coil of #18 copper wire spaced 1/2 in. long and 1/2 in. inside diameter. Connect other end of coil to stator plates of tuning condenser. To the third lug connect negative end of 1N34 diode, and connect other end of diode to positive side of meter.

At the positive meter terminal a .00025 mfd. mica condenser and one side of a 10000 ohm volume control are also connected. Free end of condenser and center arm of volume control are both returned to the common ground. The volume control is mounted through a hole in the metal case, opposite the tuning condenser. Next mount a closed circuit type phone jack on front panel in front of tuning condenser. If this area is too crowded, put jack on same side of box as the tuning condenser. Run a wire from phone plug ground lug to tuning condenser ground lug. Then replace bottom on cabinet and your unit is all ready to use. Upon testing the instrument if the meter reads in reverse, this may be corrected by reversing the meter connections or by reversing the crystal diode in the circuit.

To use this unit as an r. f. probe in alignment procedure, simply hold instrument so that an-

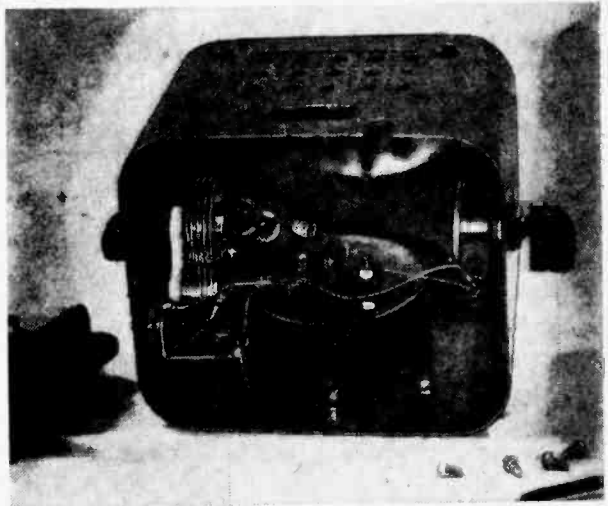

With assembly complete, back of case can be screwed on.

tenna is near r. f. coil of transmitter. Approach it gently, then adjust instrument as follows: Turn volume control all the way out, then peak tuning condenser for maximum output on the meter and move on to the next stage; then repeat the performance. Continue this procedure until antenna is reached, then set instrument with its antenna parallel to transmitting antenna and at such a distance from it that meter will read approximately .8 m.a. with tuning condenser peaked to maximum. Adjust antenna tuning while watching meter, also returning final amplifier stage every time any antenna adjustment is made. If meter runs over scale bring it back to .8 m.a. by tuning in volume control. When maximum output has been reached it is a good procedure to go back over previous stages of transmitter and repeak them while leaving instrument in the last position used for tuning and adjusting antenna. While re-peaking r. f. trimmers, note that some of them seem to tune very broadly. In this case leave trimmer at central

point of resonance even if there seems to be a slight decrease in output. This merely shows an abundance of excitation which is needed to keep final output from falling off when oscillator frequency is changed under modulation, when frequency modulation is used. Also in high-level amplitude modulation the carrier can be broken up if there is insufficient excitation to the final amplifier.

The 3-turn coil will tune only to the ultra-high frequencies. This is where the $2\frac{1}{2}$ mh. r. f. choke comes into the picture. No provisions for tuning the lower frequencies were found necessary since radiations at these wave lengths are more easily detected. The tuning condenser is used as a variable capacity across the r. f. choke, shunting the r. f. picked up by antenna to ground until proper reading is reached on the meter. In any case, if insufficient reading is obtained upon meter scale, a jumper wire with alligator or battery clips on each end can be used to ground instrument case to transmitter case; keep this lead as short as convenient.

Checking Transmitters

In checking an amateur or B.C. transmitter the same procedure may be used. It is especially useful for checking quality and watching for over modulation. For modulation checking, a greatly increased meter reading will be noticed at 100% modulation. Splatter or over modulation can usually be determined by distortion, or perhaps by irregular reading if the meter has fast

action. Excessive negative peaks are the greatest offenders at high levels as they tend to break up the carrier pocket or wave form and result in rough side bands or splatter. Since a higher level of amplitude modulation can be reached with the positive peaks predominating, a negative clipper system is sometimes introduced; but this is advisable in voice work only as a certain amount of the natural tone is lost. A simpler way to obtain a similar result would be to reverse two leads on either input or output of an audio or modulation transformer, preferably near the output of the speech system, thereby increasing positive peaks in proportion to negative peaks. This can be detected on the instrument by an increased reading on the meter, before distortion sets in. Also this system does not impair the quality. At the ham shack merely set it on the operating desk, set controls for correct meter readings and watch meter for above effects. You may also plug in a pair of ear-phones for aural checking. To align a multi-element or beam antenna, simply use this unit in this case as a field strength meter.

Brush Kink Helps to Keep Soldering Iron Clean

• When doing a lot of soldering, hold soldering iron against a revolving wire brush occasionally. Stiff wire bristles remove all traces of flux scale and solder, allowing iron to be quickly retinned. —FRED C. YOUNG.

Repair Any of These

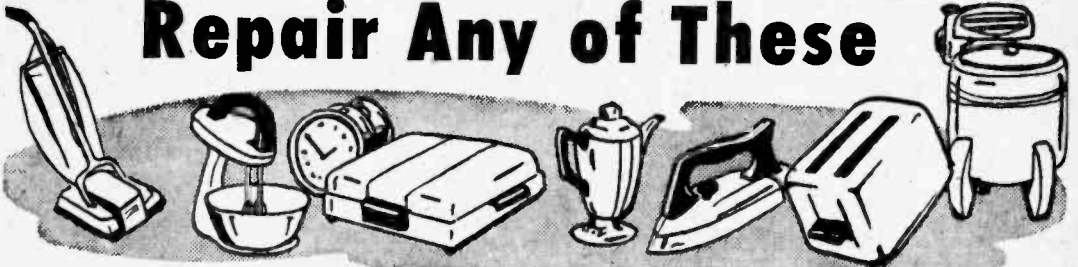

Handyman's Electrical Guide Makes You an Expert in an Evening

At last you can tackle any electrical job around the house with professional skill! The "Handyman's Electrical Guide," a new 192-page handbook for practical men, shows you exactly how to proceed on any electrical job. No questions are left unanswered. Written in simple, easy-to-understand language by men who are experts in their field. No previous electrical knowledge or experience needed! Now you can do your own electrical repair jobs and save hundreds of dollars. Nearly 600 illustrations—192 pages and 26 different "how-to-do-it" projects ranging from repairing toasters to rewinding motors.

TELLS HOW TO—Service Electric Mixers—Fans—Lamps—Washers—Irons—Vacuum Cleaners—Electric Grills—Toasters and Small Table Appliances—Car Clocks.—Service and Rebuild Motors—Build an Electroplating Outfit—Design Transformers—Repair Meters, and many others.

SCIENCE AND MECHANICS

450 East Ohio St., Dept. R-452, Chicago 11, Ill.

Send only **50c**



You will be amazed at the valuable information in this big handbook. On the very first job you can save 10, 20, or even 100 times the cost of the handbook. Order a copy today. Price 50c prepaid. (No C.O.D.'s, please.)

SCIENCE AND MECHANICS
Dept. R-452, 450 East Ohio St., Chicago 11, Ill.

NAME _____

STREET _____

CITY _____

ZONE _____

STATE _____

New fashions in TV antennas being tested for receiving the Ultra High Frequency stations recently opened by the FCC. Best reception depends on picking the right antenna for station frequency and location. (See text and Fig. 1.)

EVEN though you may live 75 to 200 miles from the nearest TV station, you may still enjoy top video shows. Today's receivers are built with an average of only 20 tubes and a "life-size" 20-21-in. screen. Yet these sets, through improved circuit design, offer two or three times the sensitivity of earlier sets containing 30 tubes and a small 10-in. picture.

Just because your neighbors had tough luck five or six years ago is no reason for you to hesitate today. First, you can buy a top-notch TV chassis from any of the leading mail order radio supply houses for about \$150.00. Next, you install your own *tailor-made* antenna according to these directions and, barring unusual geographic conditions, you're all set to tap the flood of top TV programs.

When you choose a TV chassis, look for a description of its R.F. tuner. Insist on a set with a Standard or Hallicrafters type *turrent* tuner. Remember the huge Ultra High Frequency spectrum recently opened by the FCC will permit at least one TV station in every U. S. community. Many present sets will not tune these extremely high frequencies without a costly external converter or reworking the circuit.

The R.F. *turrent* type tuner made by Standard Coil Products is built around a drum with snap-in coils for each of the present 12 channels. Within any 50-mile radius there can never be more than seven TV stations because of adjacent and co-channel interference (one TV station overriding another's signal.) These tuners, therefore, have five coil strips that will never be used unless you move to a new locality. When UHF TV

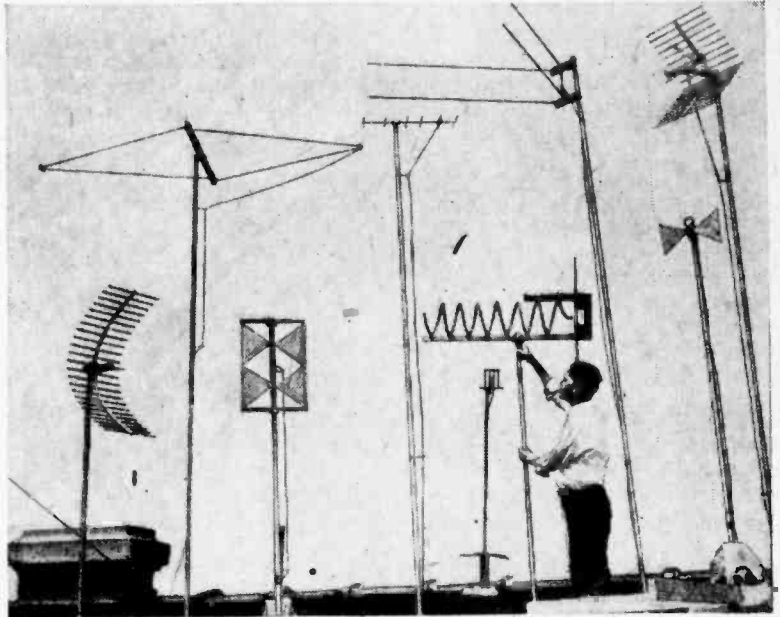

Pick the Right Antenna for Top TV Reception

You can save up to \$200 by installing your own TV (while observing safety precautions) and improve reception on your set by choosing the antenna best suited for your set and location.

By THOMAS A. BLANCHARD

comes to your town, all you'll have to do is check the channel number and order from your radio supplier a UHF coil kit. Snap out the coils from any unused channel on the tuner drum, insert the new UHF coils and the conversion is completed in a matter of minutes.

Regardless of salesmen's claims about indoor antennas, only the right outside antenna will bring you the best in TV performance. Compiled here (Fig. 1), in picture, diagram and chart form, is a non-technical description of the best-by-test types of TV antennas.

A) *V-Beam All-Channel*. This antenna designed for a maximum directivity with a gain up to 7 decibels on upper channels; has high interference and noise rejection ratio; designed for "focusing" on one particular station or location (New York City, for example, has five stations

atop the Empire State building.) Efficiency: 25-30 miles.

B) *Stacked V-Beam*. Two V-Beams connected in parallel; same sharp tuning characteristics, plus a gain up to 11 decibels on upper channels. Efficiency: 25 to 50 miles.

C) *Hi-Lo Folded Dipole*. A broadband antenna array with large element covering channels 2 to 6; small forward element tunes channels 7 to 13; elements connected in parallel provide 1.5 decibel gain on high band; 2.5 gain on low band. Efficiency: 25-30 miles.

D) *Basic 5-Element Yagi*. A folded dipole antenna cut to the exact frequency of a distant TV station, plus five forward parasitic elements (directors), and one rear parasitic (reflector) element; provides more gain than any other single antenna array; up to 13 decibels on high bands, 7 decibels on low bands. In many instances this type antenna is better than the best booster unit. Efficiency (when stacked—See H) 75-100 miles and more!

E) *True 5-Element Yagi*. Same characteristics as basic Yagi, however, instead of folded dipole

element being formed from continuous length of 1/2-in. tubing, rigid 1-in. dia. tube is used for the collector. The high front-to-back ratio of the Yagi greatly reduces adjacent and co-channel interference.

F) *Single Conical Array*. Most versatile of TV antennas; elements insert into sockets attached to ends of mast crossarm. The dipole elements can be arranged for 4 or 6 forward elements, or 2, 4 or 6 reflector elements. This antenna is usually supplied with 8 44-in. elements and covers channels 2 to 13. Efficiency: 25-30 miles.

G) *Stacked Conical Array*. Stacking the biconical array provides maximum all-channel reception in fringe areas. The two single conicals are connected in parallel with two 44 in. jumper bars (1/4 wavelength) to provide excellent broadband reception, and high-gain response through 20° broadside tuning angle and exceptional front-to-back ratio. Antenna matches 72, 150, or 300 ohm twin coaxial or lead-in cable. Efficiency: 75 miles.

H) *Multi-Stacked Arrays*. Both the biconical and Yagi antennas may be stacked in multiples

of two for reception of stations as far as 150-200 miles away. (Seasonal reception of 1000 or more miles has been verified), a TV set owner who lives quite a distance from a city with several TV stations should choose the conical stack. Where one long-distance station *only* is to be received, use the Yagi array.

If the distant city has two stations, install a separate Yagi system for each station, aiming each antenna toward each transmitter.

The foregoing antennas are intended for receiving locations where all TV signals come from the same general direction. However, suppose you live in northern New Jersey. There you have seven TV stations in the New York City area to the north, and three TV stations in Philadelphia to the south. All ten stations could be received with good results using dual antennas (one beamed north—one south) with adequate reflectors to keep adjacent channel interference at minimum. Sometimes, the antenna array becomes too weighty, and it becomes easier to use a single or stacked array turned by an electric motor mechanism. However, a motor driven device is expensive, and in northern climates, freeze-ups occur after hail and sleet storms.

Recently a "motorless" directional antenna was developed that can do almost as good a job as a motor-driven system at considerably less cost. (Fig. 2A). This device is basically a biconical stacked antenna

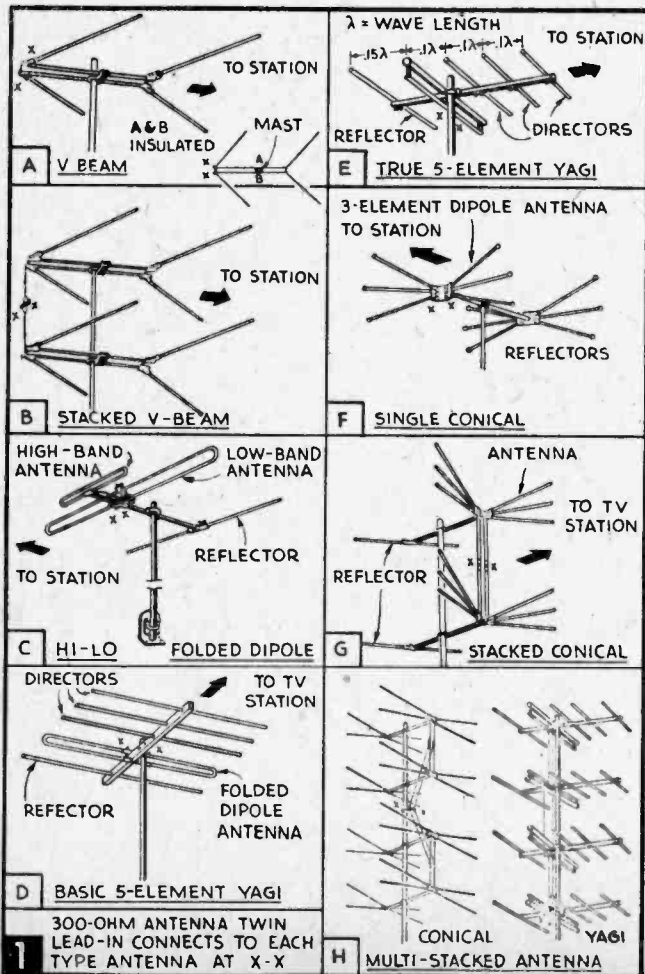

TABLE A—DATA FOR MAKING A TAILOR-MADE CONICAL OR "YAGI" TV ANTENNA

Channel Number	Frequency in Mega-cycles	Wavelength (W. L.)	Conical Element Length (1/2 W. L.)	Yagi Over-all Length (1/2 W. L.)	Director Spacing		Reflector Spacing	
					(.10 W. L.)	(.15 W. L.)	(.15 W. L.)	(.25 W. L.)
2	56-60	194"	48.5"	97"	19.4"	29.1"	29.1"	48.5"
*3	60-66	178"	44"	88"	17.8"	26.4"	26.4"	44"
4	66-72	160"	40"	80"	16"	24"	24"	40"
5	76-82	140"	35"	70"	14"	21"	21"	35"
6	82-88	130"	32.5"	65"	13"	19.5"	19.5"	32.5"
7	174-180	62"	15.5"	31"	8.2"	9.3"	9.3"	15.5"
8	180-188	60"	15"	30"	6"	9"	9"	15"
9	186-192	58"	14.5"	29"	5.8"	8.7"	8.7"	14.5"
x10	192-198	57"	14.25"	28.5"	5.7"	8.55"	8.55"	14.25"
11	198-204	55"	13.75"	27.5"	5.5"	8.25"	8.25"	13.75"
12	204-210	54"	13.5"	27"	5.4"	8.1"	8.1"	13.8"
13	210-216	52"	13"	26"	5.2"	7.8"	7.8"	13"

*Conical Antenna Cut to Channel #3 covers all 12 TV Channels.
 Folded Dipole Cut to Channel #3 covers Channels #2 to #6.

xFolded Dipole Cut to Channel #10 covers Channels #7 to #13.
 Cut "Yagi" Antenna to tune a specific channel.

†Directors are cut 5% shorter than over-all length of antenna.
 Reflectors are cut 5% longer than over-all length of antenna.
 Conical elements, however, are all the same length. } Yagi or folded dipole

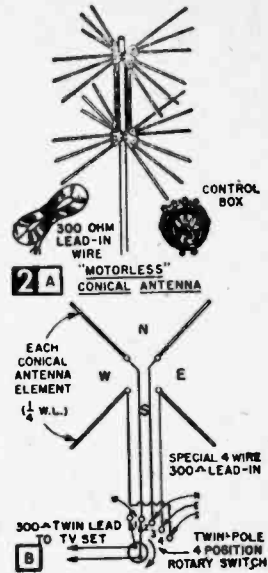

resembling a subway turnstile. On each side of the mast, the six upper elements are connected to the six lower elements with jumper bars. Instead of connecting a single twin-lead 300-ohm line to the antenna, a twin-twin (4 wire) 300-ohm line is attached to the jumper bar connections. This specially made lead-in is furnished with the antenna kit along with a selector switch. (Ray Co., 441B Summit St., Toledo, Ohio or Snyder Mfg. Co. 23 & Ontario, Philadelphia, Pa.)

When the antenna's rotary switch is in No. 1 position (Fig. 2B) the elements directed west are connected to the TV set, those behind are parasitic reflectors. Each switch position picks up signals from another direction with opposite elements acting as reflectors. The "motorless" directional antenna also comes in 3-spoke models, employing a 3-wire ribbon lead-in of 300 ohms, and a 3-position selector switch. Neither of these antennas are best for long distance reception. However, they do an excellent job in local, primary, or semi-fringe areas (if stacked).

All the various antenna arrays illustrated in Fig. 1 may be purchased from any radio supply house from \$3 to \$25 (less mast) depending upon the particular type selected. Except for the Yagi types, it is much cheaper to buy your antenna than to attempt making your own.

However, for the benefit of experimenters, Table A indicates dimensions for cutting antennas to receive each of the 12 TV channels. This table applies to dipole, folded dipole, biconical, and Yagi systems. The overall length of an antenna for any given channel is half the wavelength of the signal transmitted. Thus the tip-to-tip length of the folded dipole (Fig. 6) cut for channel 10 would be 28½ in. The reflector is cut about 5% longer than the antenna, while directors are about 5% shorter.

Table A indicates either of two systems for spacing directors and reflectors. One system calls

for spacing directors at .10 wavelength intervals while reflectors are located .15 wavelength behind the antenna. The other system advocates .15 wavelength spacing for directors and .25 wavelength spacing for reflectors. The symbol for wavelength is the Greek letter "λ", Lambda; in English, the letter L. (See E in Fig. 1)

Reflectors and directors direct weak signals to the antenna. Reflector elements beam any stray signals back where they belong. The reflector also helps to cut off unwanted signals from the rear. Neither reflector or director elements make any connection to the antenna. They are merely mounted to the crossarm. If crossarm is metal, the antenna collector elements are mounted on an insulating plate where antenna lead-in wire is connected ("X-X" on Fig. 1).

Now that you know the relative merits of the various antenna systems and how they fit your geographic location, you are ready to buy the necessary components and install the antenna. Local radio shops and mailorder houses can supply everything you need to do a professional antenna installation job. In rural and suburban areas, a 10 ft. mast is usually high enough. In cities the higher the antenna, to clear other buildings or obstructions, the better.

If there are TV stations in your city and you are not interested in distant reception, disregard an elaborate antenna; A or C in Fig. 1 is ample.

Urban reception presents a noise problem. Twisting the 300-ohm lead-in or use of 72-ohm coaxial cable will minimize ignition disturbances. Coaxial lead-in may be used with the conical antenna (F in Fig. 1).

TV masts come in 5 and 10 ft. lengths with one end crimped for telescoping into a second section if necessary. Protect high masts of rural installations with enough guy wires to keep high winds and ice from breaking them down. Locate masts far enough from electric power wires that

the antenna will not fall on the wires if it should blow over. Make sure lead-in wires can not blow or fall on power wires. Chimney mounts (Fig. 4), sold by your parts supplier simplify attaching the antenna and mast to a housetop, but a wall mounting (Fig. 3) is preferred when convenient. Installing the antenna away from the chimney eliminates the collection of soot and resulting corrosion that reduces antenna efficiency after a few months.

If your home is of brick construction, and the chimney mount is your best bet, due to difficulties in attaching a wall bracket; be sure your mast is aluminum and not cadmium or zinc "bright dip" finish. Most antenna arrays are made of aluminum tubing, but masts are ordinarily of steel. In as little as one year, the mast

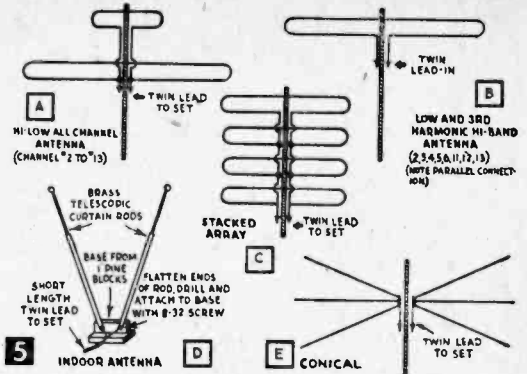

Methods for connecting antenna segments of folded dipole or Yagi type antennas to lead-in. The indoor antenna (D) is a dipole from which the modern conical design antenna stems. Connect conical antenna as shown in illustration (E).

can rust through and topple over in a wind storm. If you must use a steel mast, apply two coats of good asphalt roof paint to it before installing. Repaint the lower half once a year. This precaution isn't necessary with a wall mounting because the antenna is not close to the hot fumes which speed corrosion.

A TV antenna is light and may be assembled to mast and one end of the lead-in on the ground. You can use heavy twine to hoist the complete unit to the rooftop if there are no intervening obstructions. Secure the mast to the mounting bracket and orient the antenna toward your TV station. Stand-off insulators guide the antenna lead-in to the receiver. Two or three snap-on insulators secure the lead-in to the mast, while screw types are used on the sidewall of the house. Twist the 300-ohm twin-lead before snapping into the plastic stand-off to reduce stray ignition and electrical pick-up.

At the point where the lead-in enters the home, drive a 4 or 5 ft. length of pipe into the ground. Bring a length of #8 galvanized iron, copper or aluminum wire from the mast and clamp to the ground pipe (Fig. 3). The solid cable protects directors and reflectors, cross arm and mast from lightning, but does not protect the antenna elements themselves. Therefore, a lightning arrestor (Fig. 3D) is added across the lead-in to protect your set.

Attach the lightning arrestor to house sidewall with screws provided, or clamp to the ground pipe if type shown in Fig. 3D and fit the 300-ohm twin lead-in into the slot of the molded plastic box. When screws over the 300-ohm lead-in slot are tightened, the toothed washers bite into the plastic making a firm contact with lead-in, so that no wire skinning is necessary. Bring the lead-in into the home through a basement window or sash, keeping it as short as practical. Cut off any excess lead-in. Skin off insulation from the end and attach leads to antenna terminals of TV set.

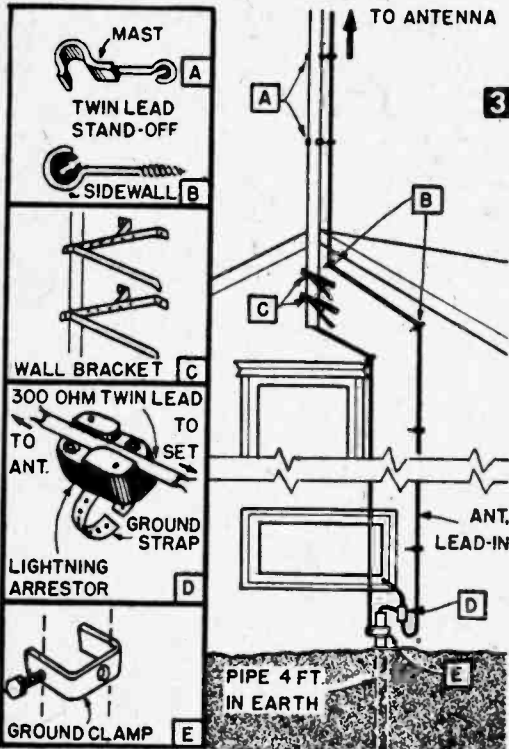

For maximum lightning protection, ground TV antenna mast to earth with No. 8 or heavier iron, aluminum, or copper wire (bare). Use clamps as shown.

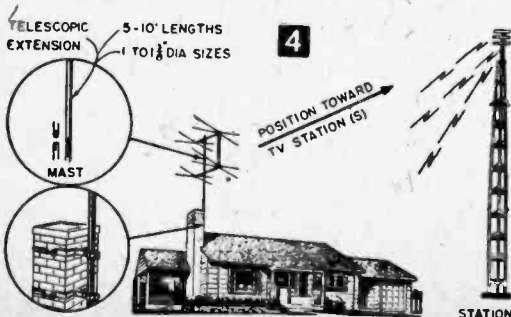

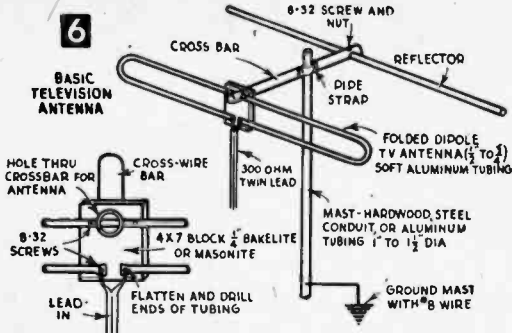

A folded dipole antenna's construction.

In remote areas, precise orientation of antenna toward station will boost the signal. After installation is complete, have the family watch the TV picture as you turn the antenna slightly to left or right as may be required. Lock bracket screws once maximum brightness is obtained.

Where stations in the high band are to be received (Channels 7 to 13) try this simple antenna balancing trick for amazing results. Open the foil wrapping from a pack of cigarettes, and wrap it lengthwise around the TV lead-in near the set. Press the wrapping snug around the lead-in. With set tuned to a high-band station, slide the foil up and down the lead-in wire. At a point ranging from a few inches to a foot or so from the set, you will find that the "impossible" sta-

tion comes in strong and bright.

If there is only one high-band station, the foil need not be disturbed again. If more than one high-band station is located in your area, move the foil to another position for best reception. The foil trick is often better than a booster, but works only from 174 to 216 mc—the higher the frequency, the more effective it proves to be.

When the TV station is far away (or sometimes nearby) some channels will not produce a picture. If your neighbor gets the particular station, but you don't, and your set is OK!—you're in a *dead spot*. Often this condition is cleared up simply by moving the TV antenna to another position on the roof. Swivel roof mounts are available to replace chimney or sidewall mounts. Even a change of a few feet has cleared up this high frequency quirk.

In one case in a mountainous rural area a serviceman assembled and set up the antenna on the ground, and attached the lead in. Turning on the set, the fellow was amazed to find he was getting excellent pictures in an "impossible" location with the antenna propped against a pole in the backyard. The serviceman then installed the antenna on the roof, sure of even better results, but nothing came in. So the antenna and mast were permanently installed in the backyard.

All of which proves that if you find yourself in a dead spot, try any and all locations. Your friends may laugh, but you may get better TV than you ever expected.

Low-Loss Uniform-Impedance Antenna Switchboard

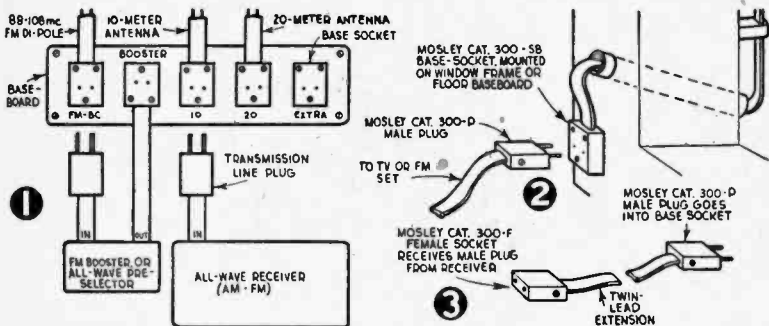

DX radio hobbyists, hams and experimenters can solve the problem of antenna switching and booster in-and-out switching by the use of Mosley polystyrene 300-ohm twin-lead male plugs, and female base-sockets (Fig. 1). This switchboard does away with the common hay-wire switching arrangements using knife-switches or toggle switches, which often result in UHF losses and impedance changes due to poor insulation and capacitances in the switches. By this method, many different combinations are possible whereby boosters, ham-band preselect-

tors, AM-FM receivers and transmitters may be plugged in or out of various dipole antennas for highest efficiency. Mount sockets on a hardwood baseboard and label sockets as shown. Place the switchboard for shortest leads to apparatus. Use 300-ohm ribbon twin-lead for all connections shown.

Low-Loss Uniform-Impedance Antenna Connectors for TV Sets

When connecting outdoor antennas to TV sets, insert a pair of Mosley 300-ohm transmission line connectors in the twin-lead between window and set. Mount a base-socket on window frame or floor baseboard, and connect a male plug to lead going to receiver (Fig. 2). Thus, the set may be quickly disconnected when the housewife wants to move the receiver for cleaning, or a twin-lead extension may be added easily when you want to move the receiver to another place in the room. In the latter case, connect a female socket to one end of extension, and a male plug to other (Fig. 3).—A. T.

Radiotelegraph Station for "Novice" Operators

This unit provides you with just the tool to get off to a flying start in ham radio operation

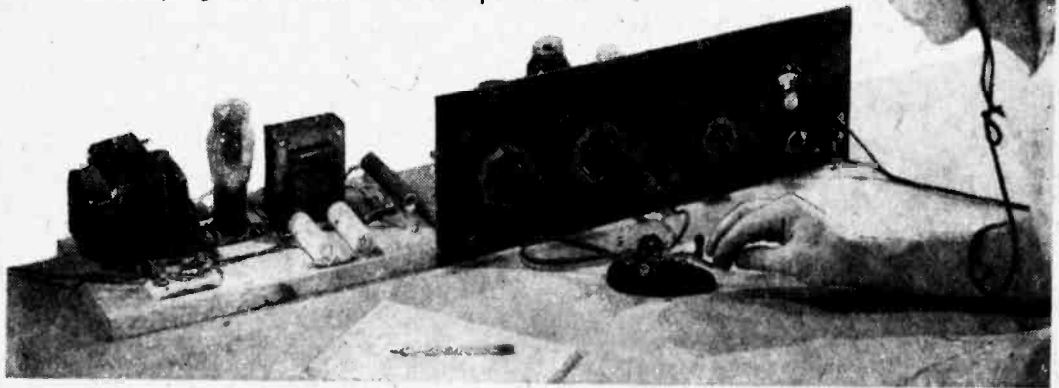

By C. F. ROCKEY, W9SCH

NOW may be just the time for you to follow up on that ambition to get into "ham" radio, and this unit should certainly help you do it easily. As you may know, the Federal Communications Commission, to encourage ham activity, is now issuing a new class of amateur "ham" radio license—the "novice" class—with vastly simplified examination requirements. (For specific details, write the FCC field engineer's office in any large city or directly to the Federal Communications Commission, Washington 25, D. C.) This simplified examination should make it much easier to become a licensed "ham".

The unit shown here is designed to provide you with a good, easily-constructed, relatively inexpensive, amateur radiotelegraph station

Fig. 1. Complete amateur radiotelegraph station set up for "novice" operation. Power supply unit is at left, combined transmitter-receiver unit is at right. The baseboard can be made of soft pine.

which would be especially effective for the "novice" operator. Complete new parts for the entire unit will cost about \$60 or \$80 with power supply); the cost will be much less, of course, if you have a radio "junk box". You can do your building with hand tools on the kitchen table some Saturday afternoon.

How well does it work? Well, when operated with an antenna system (shown), and after you've had a bit of practice, you'll find the transmitter will have a consistent range of about 50 miles in daylight and of over 200 miles at night. The receiving range is limited only by the properties of the frequency-band used. Also, when a suitable vibrator pack or dynamotor power supply is em-

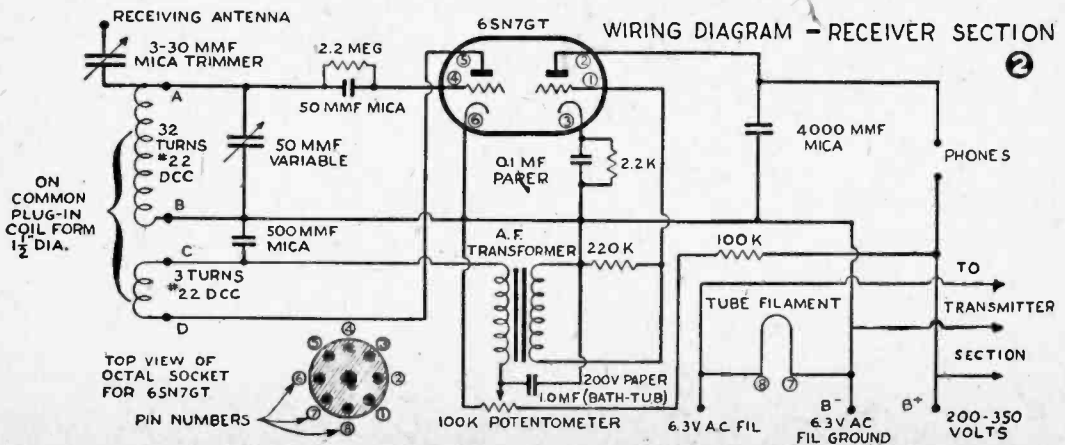

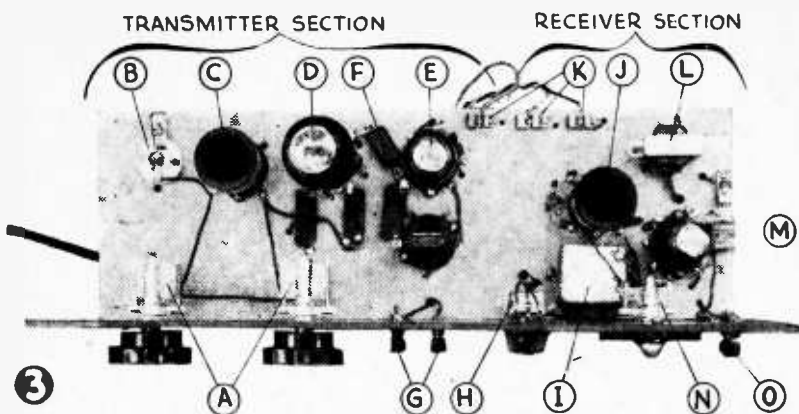

Receiver and transmitter sections (mounted on one baseboard) viewed from above. A, transmitter tuning capacitors; B, antenna tuning lamp socket; C, coil (trans.); D, 6L6G tube; E, 6J5G tube; F, crystal; G, telegraph key terminals; H, regeneration control potentiometer; I, IMF condenser; J, coil (rec.); K, power supply terminals; L, A.F. transformer; M, 6SN7 tube; N, 50 MMF tuning condenser for receiver; O, headphone terminals.

ployed, instead of the ac power supply as shown, this unit becomes a highly effective portable station, requiring only a 6 volt automobile system for power, and ideal for storm, flood, or other emergency situations.

Building the Receiver

Because it will be immediately useful in learning operating procedure and code until your license arrives, let's first build and adjust the receiver section. The receiver is of the simplest regenerative type, and you'll find it sensitive, quiet, and reasonably selective—comparing favorably, in fact, with many inexpensive, "communication" superheterodynes, and costing far less than the superhets. It may take a bit more practice to obtain the best results with it, but the skill thus gained will pay dividends in the appreciation of a truly high quality receiver later.

Prepare the baseboard from thoroughly dry wood (Fig. 4), coat it with good quality lacquer or varnish, and allow this to dry thoroughly. Don't use ordinary "lead" paint—particularly black paint, as it is a poor electrical insulator and might cause high-resistance "shorts". Carefully arrange parts to be mounted on the baseboard (Fig. 3) before fastening any down with

#6 rh brass wood screws, 3/4 in. long.

In wiring the set, (do as much as possible before attaching panel) place the common B minus-filament-ground leads first, along with the other 6.3 volt filament lead. Then start from the antenna connection and wire the set in the order that the signal passes through the circuit. Trace with a pencil, on the wiring diagram, each lead as it is placed, to minimize errors.

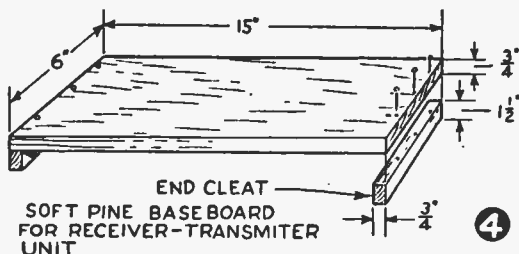

Several parts and leads are installed "below deck", in the space beneath the board. Just what parts are so placed rests upon your judgment. As a guide, mount parts "below deck", where the components are small enough to fit and the leads can be shortened or made more direct by placing underneath. When you've done all the wiring you can without drilling the panel, drill it and mount the regeneration control potentiometer, tuning condenser and dial, and the headphone binding posts on it; then screw it to the baseboard. Now complete the wiring and check. If connections are okay, you can wind the coil, which consists of 2 windings of #22 double-cotton covered wire, separated 1/8 in. on a 1 1/2 in. coil form. Each winding is "close wound", which means that the individual turns are adjacent to each other, with no space between. The grid winding consists of 32 turns, while the plate or "tickler" winding is of 3 turns. Wind both in the same direction, and connect them exactly as shown (Fig. 5) or regeneration won't occur.

Plug coil and tube in the correct sockets, and then connect the headphones and power supply (but not the antenna). Turn on the power supply, allow the tube to warm up and put on the headphones (resting them at first over the cheekbones, not over the ears). Slowly advance the regeneration control—until a definite increase in background hiss is heard. This is the "point of oscillation" one third to two thirds of

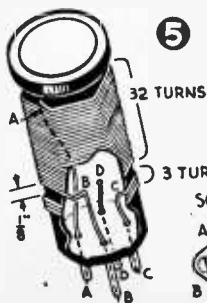

RECEIVER COIL WINDINGS AND CONNECTIONS

CONNECT LETTERED ENDS TO CORRESPONDING PINS ON FORM. (LEAD INSIDE OF COIL)

- A - TO STATOR OF TUNING CAPACITOR
- B - TO B- AND ROTOR OF TUNING CAP
- C - TO PLATE OF TUBE
- D - TO A.F. TRANSFORMER AND 500 MMF CAP

MATERIALS LIST: NOVICE RADIOTELEGRAPH STATION

No. Req'd	Part
1	baseboard, wood, 15 x 6 x 3/4" (for entire unit)
1	panel, 17 x 7 x 1/4" (for entire unit) may be plastic, Masonite or plywood
1	6SN7 GT Tube
1	octal socket, for above-base mounting (Eby Co.)
1	four-prong socket for above-base mounting (Eby Co.)
1	standard plug-in coil form (4 prong 1 1/2" diameter) (Bud Radio Co.)
1	50 MMF variable capacitor (Bud also) may be old broadcast receiver condenser "ripped-down" to 3 plates)
1	tuning dial for receiver, vernier type preferable (National Type BM)
1	knob, for regeneration control
1	potentiometer, linear taper, 100,000 ohms (Mallory)
4	Fahnestock clips
1	3-30 MMF mica trimmer capacitor (Aerovox)
1	500 MMF mica capacitor (Aerovox)
1	50 MMF mica capacitor (Aerovox)
1	4000 MMF mica capacitor (Aerovox)
1	1.0 MF 200 W. V. paper capacitor ("bath-tub" type) (Aerovox)
1	0.1 MF 600 W. V. paper capacitor (tubular) (Aerovox)
1	transformer, single plate to single grid interstage—Stancor or from old broadcast receiver—3 to 1 turns ratio
A "single plate to push-pull grids" transformer may be used also. Use the entire secondary, ignoring the center-tap	
1	2.2 meg 1/2 watt carbon resistor (I. R. C.)
1	100,000 ohm 1 watt carbon resistor (I. R. C.)
1	2200 ohm 1/2 watt carbon resistor (I. R. C.)
1	220,000 ohm 1/2 watt carbon resistor (I. R. C.)
1/4 lb.	#22 D. C. C. magnet wire (for coils)
25 ft.	push-back hookup wire
miscellaneous screws, soldering-lugs, etc. (CANNOT be used). Trimm	
1 pr.	good quality "magnetic" headphones (crystal type CANNOT be used). Trimm
Variation of $\pm 25\%$ in value of any components specified for any unit is permissible, without sacrificing performance. However, paper capacitors should not be used where mica are specified.	
In addition, the power supply unit, providing 200 to 350 volts of well-filtered D. C. at 175 milliamperes; and 6.3 volts A. C. at 1.5 amps, will be required for the entire unit. This will be described in Part 2. (If a large "A. C." type broadcast receiver, preferably of the older type is available, voltages required may sometimes be obtained from it, until a power supply unit can be obtained.)	

the way "up" on the control, and the noise should build up and die away smoothly as the control is advanced and retarded about this critical point. If a very loud, almost uncontrollable howl or squeal occurs, reverse the connections on the secondary (grid side) of the audio transformer. (Different makes of transformers are "phased" differently by the manufacturer, and thus correct connections for each type cannot be given here.) When the transformer is once connected correctly, the system is completely stable. If a "single plate to push-pull grids" transformer is purchased, use the entire secondary, neglecting the center tap.

If you can't get the smooth oscillation described at any setting of the control, and the set is wired correctly, re-check the coil. Either both windings may not have been wound in the same direction, or the connections to the pins may be wrong. After you obtain smooth oscillation, you then connect a short receiving antenna. Except in extremely poor city locations, or possibly in the sparsely-settled southwest, a single wire about 20 ft. long, run around the picture-molding, should provide plenty of signal pickup.



(Greater length merely increases the chance of "blocking" from nearby transmitters.) In any case, install the receiving antenna so that it is as vibration-free as possible (tack it down every 2 ft. along molding with thumbtacks).

Oscillation should be readily obtained, with the antenna connected, across the entire tuning range. If it isn't, the antenna series trimmer condenser must be "backed-off" (capacity decreased). For the strongest possible signals, however, set this condenser to the greatest capacity consistent with smooth oscillation throughout the tuning range. This antenna condenser normally will also affect the tuning range to a slight degree. Dial calibration will be different with different antennae.

With a receiver of this type, maximum sensitivity occurs with the regeneration control set at the point where oscillation just begins. For C. W. (Code) reception, the control will be just above this point; for radiophone it's just below. Actual operation will show best adjustment for each.

With the coil and variable capacitor specified, this receiver will tune the frequency band from about 3200 to 4100 kilocycles. Within this range lies one of the most valuable and consistent of the amateur assignments; the radiotelegraph band between 3500 and 3800 kilocycles and the radiophone band between 3800 and 4000 kilocycles. Within these bands each evening may be heard some of the best amateur operators in the world. It will amply repay the beginner to listen to and emulate these, thus assisting his mastery of the important details of radio operating procedure. For other tuning ranges, up to about 15 megacycles, you can wind and plug in other coils instead of the one specified, if desired (this data available in any radio-amateur handbook).

This receiver is for use with headphones, which are preferred by experienced radiotelegraph operators. If "loudspeaker" operation is desired, a power-pentode A. F. (such as a type 6F6G amplifier) may be resistance-coupled to the second (amplifier) section of the 6SN7 with little difficulty.

WARNING!

- A radio operator's license is required before you can broadcast with this device. Violators are subject to severe penalties. For specific information on obtaining an FCC license, write to your district office or directly to FCC, Washington, D. C.

How to Construct and Use Transmitter and Power Supply Units

By C. F. ROCKEY, W9SCH

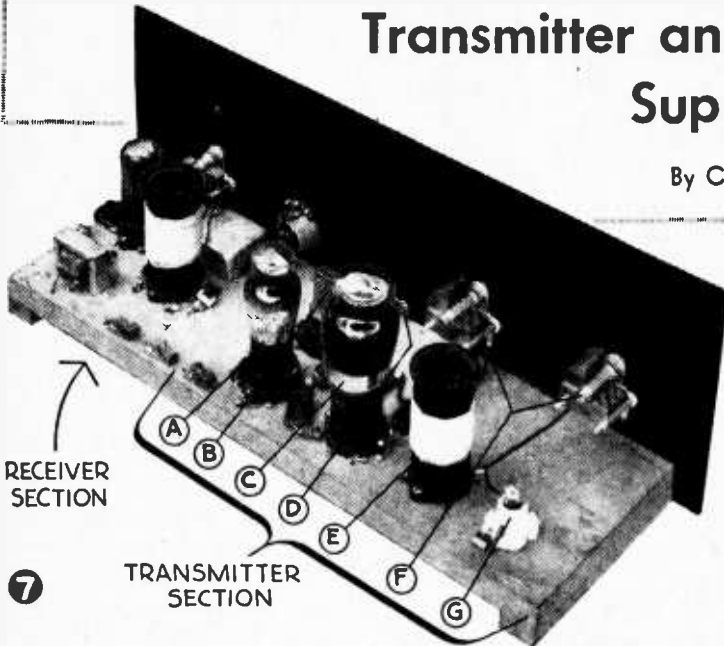

Left, view of transmitter and receiver sections. See also Figs. 3 and 6 in Part I. (A) 6J5G tube; (B) crystal; (C) 6L6G tube; (D) telegraph key terminal; (E) coil; (F) transmitter tuning capacitors; (G) antenna tuning lamp socket.

Below, parts layout of the power supply unit. (A) filter capacitors; (B) power line switch; (C) 50 watt resistor; (D) filter choke; (E) Fahnestock clips for power terminals; (F) 6.3 V. AC; (G) rectifier tube socket; (H) power transformer.

THE preceding article on this novice-set, explained the construction of the receiver portion of this radiotelegraph station, which is ideally designed for amateur FCC "novice" license operation. Now let's take up the power supply unit (Figs. 8 and 9). The layout of parts in a power supply unit isn't critical, but plan for reasonable spacing for points of high voltage, short connecting leads, an orderly appearance, and easy replacement of parts. Make sure the "plus" or positive side of each electrolytic capacitor is connected to the B+ (choke) side of the system; otherwise they will short-circuit and destroy themselves, and possibly the rectifier tube as well.

For the rectifier tube use either the 5Z3 or the somewhat newer 5U4G. Both are electrically identical but the easier-to-connect 5Z3 has a 4-pin base with wider pin spacing and thus a somewhat higher breakdown voltage.

Don't omit the .01 mf capacitor from one side of power line to B minus; if you do, the receiver may be quite unstable and produce considerable hum. You can omit the .005 mf capacitors, one from each plate of the rectifier tube to B minus. But if the receiver hums strangely at certain frequencies, even after the B minus is well grounded, add these capacitors. Where the power line in the building is not properly fused, connect a 2-ampere fuse as shown in Fig. 9. But most house wiring fuses provide ample protection for such a relatively small (about 150 watt total)

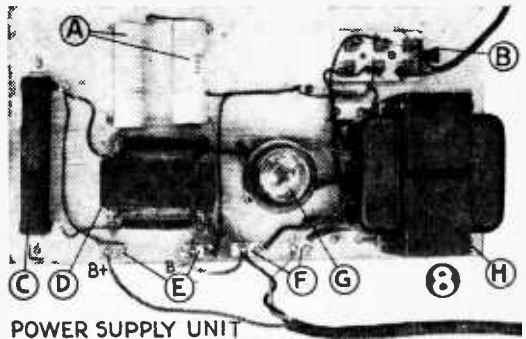

POWER SUPPLY UNIT

load on the ordinary house line.

Use the highest quality power transformer and electrolytic capacitors that you can afford, as cheap parts here usually don't live long or perform well. Test the power supply with a standard volt-ohm-milliammeter (from any radio service shop). The dc output voltage should range between 300 and 425 volts, without a load, while the filament voltage may be from 6.1 to 7 volts under similar conditions.

After building the receiver and power supply, mastering the receiver's operation and receiving your "novice" license, you can construct the transmitter (Figs. 7 and 10). Here again, use good quality parts and provide short, direct leads, since the law concerning what shall be put on the air is strictly enforced, and every amateur

must know that both his signal quality and mode of operation are above reproach. The crystal-controlled oscillator makes it practically impossible for this transmitter to operate *off-frequency*, that is, in other than a duly-designated amateur band. The *pi-network* output circuit filters out harmonic radiations, minimizing interference to other services. Make sure your parts layout has short, direct radio-frequency leads, convenient and accessible wiring and parts for replacement and repair, and a workmanlike appearance.

Make well-soldered connections, and use reasonably short leads for the crystal oscillator is a simple, stable "pierce" type. Choose a crystal frequency on or near that of the stations you most desire to contact or if you hold a "novice" class license, choose a frequency between 3700 and 3750 kilocycles. To be on the safe side, pick a crystal whose frequency is at least 5 kilocycles within either edge of the amateur band.

For the 6L6G power amplifier, which uses a sensitive beam-power tube, to avoid instability use the absolutely shortest, most direct connection for the by-pass capacitor (4000 *mmf.*) between grid and cathode, and for the direct connection from the plate of the 6L6G through the 4000 *mmf* mica capacitor to the first variable output circuit capacitor. Place the by-pass capacitor from the cathodes of the tubes to common B minus as close to the cathode connection of the power amplifier as possible, using a minimum length of leads.

The coil in the output tuning circuit (the "tank" coil) is close-wound on a form like that used in the receiver coil (see Fig. 5) with 45 turns of #22 D.C.C. magnet wire. Bring the 2 ends of the coil to any 2 convenient prongs, corresponding to the connections used on the 4-

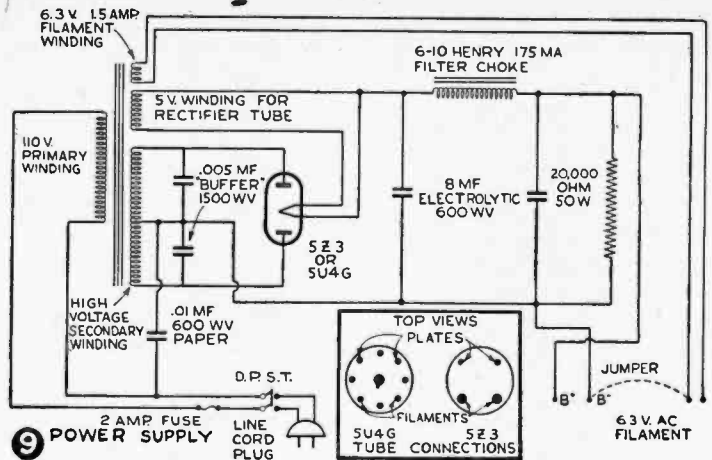

prong socket into which it is plugged. The dial-lamp bulb, shunted with a small piece of coiled #22 magnet wire, is connected in series with the antenna, and serves as a qualitative antenna-current indicator. This indicates immediately if anything happens to the system during a contact, and also tells you whether the transmitter is tuned to peak efficiency at all times.

When the transmitter section has been wired and checked for correctness, connect the power supply and key and insert crystal oscillator 6J5G tube and crystal into their proper sockets. (Don't insert 6L6G amplifier tube yet.) When the cathode of the 6J5G tube reaches operating temperature, hold the key down with a weight, or short-circuit it. Now, holding the 2 watt neon glow bulb by the glass portion, away from the base, (*caution! high voltage!*) touch the tip to the grid connection (pin No. 5) of the power amplifier. A bluish-red glow should appear in the neon bulb. If it doesn't appear, recheck the crystal oscillator circuit wiring, test the 6J5G tube and, if available, substitute another crystal for test purposes.

Always remember that high voltages used in this equipment may cause severe and occasionally fatal shocks. So follow the usual common-

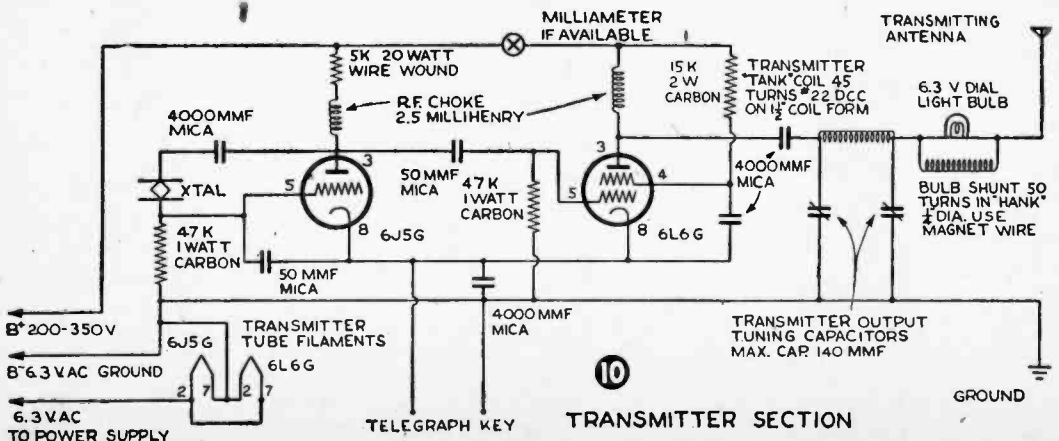

MATERIALS LIST: NOVICE RADIOTELEGRAPH STATION

Power Supply

- | No. Req'd. | Description |
|------------|---|
| 1 | A.C. line cord, with plug |
| 1 | double pole, double throw knife type switch, porcelain base |
| 1 | power transformer (Thordarson) suitable for line frequency, with following windings:
110 volt primary
6.3 volt filament winding, capable of supplying at least 1.5 amperes
5 volt, 3 amp. winding for rectifier filament.
high-voltage winding, center-tapped, 350 to 400 volts each side at at least 175 ma. |
| 1 | 0.01 mfd., 600 W.V. paper capacitor |
| 2 | 8 mfd., 600 W.V. electrolytic capacitor—may be double unit if desired |
| 1 | 6-10 henry or higher, 175 or 200 ma., filter choke (Stancor) |
| 1 | 20,000 ohm 50 watt, wire wound resistor (I.R.C.) |
| 4 | Fahnstock clips, or binding posts |
| 1 | socket for rectifier tube (Eby, top-of-base mounting; 4 prong for 5Z3 tube, 8 prong (octal) for 5U4G tube) |
| 1 | 5Z3 or 5U4G rectifier tube (see text) |
| 1 | baseboard for power supply, 10 x 12 x 3/4" |
| 2 | .005 mfd., 1500 volt "buffer" capacitors (see text) |
| 1 | 2 amp fuse, with holder
wire, screws, solder, etc. |

Transmitter Section: (over and above that required for receiver)

- | | |
|---|--|
| 1 | 6J5G tube |
| 1 | 6L6G tube—6V6G may also be used, with somewhat reduced power.
("GT" type usable but not recommended) |
| 2 | octal sockets, top-of-base mounting type |
| 1 | five prong socket, top-of-base mounting type |
| 1 | four prong socket, top-of-base mounting type |
| 1 | transmitting quartz crystal, in holder ("xtal")
frequency within 3500-3800 KC for regular amateur use
frequency within 3700-3750 KC for "novice license" use |
| 1 | adapter (if crystal does not fit 5 prong socket) |
| 1 | four prong coil form, 1 1/2" dia. |
| 4 | 4000 MMF mica capacitors |
| 2 | 50 MMF mica capacitors |
| 2 | variable capacitors for transmitter output circuit—
140 MMF max. cap. "midget" |
| 2 | dials or knobs for transmitter tuning capacitors |
| 2 | 2.5 millihenry R.F. chokes |
| 2 | 47 k (47,000 ohms), 1 watt carbon resistors |
| 1 | 15 k (15,000 ohms), 2 watt carbon resistor |
| 1 | 5 k (5,000 ohms), 20 watt wire wound resistor* |
| 2 | 6.3 volt, blue bead dial lamp bulbs (one for spare) |
| 1 | socket for dial bulb |
| 1 | Fahnstock clip (transmitting antenna connection) |
| 2 | 2-watt neon glow-lamp bulbs (one for spare) for tuning (General Electric) |
| 2 | binding posts (telegraph key connections) |
| 1 | straight telegraph key |

wire and insulators for transmitting antenna, about 150 ft., #14 enamelled, hard-drawn

A calibrated amateur-type absorption frequency meter is highly recommended, but not absolutely essential; also, a good quality D.C. milliammeter, 0-200 ma. scale, is helpful for properly tuning any amateur transmitter. The negative side of the meter should be connected toward the transmitter, the positive toward the power supply.

* A unit with a lower wattage rating would permit a saving of less than 25c. The unit specified provides additional safety-factor, particularly if set is placed in a cabinet where air-circulation is poor.

Variation of ± 25% in value of any components specified for any unit is permissible, without sacrificing performance. However, paper capacitors should not be used where mica are specified.

sense electrical precautions while adjusting the equipment.

When the neon glow shows there is R.F. energy at the amplifier grid, open the key and insert the 6L6G tube in its socket (transmitting antenna should not be connected). Meanwhile, set output tuning capacitor on the antenna side at maximum capacity (plates completely meshed).

After 6L6G tube has warmed up, close the key and hold glass bulb of neon-lamp against the stator plates of the tuning capacitor nearest the tube. This capacitor should be immediately rotated through its entire range until a glow appears in the neon bulb. Adjust this capacitor carefully until glow is at maximum brilliancy, then open the key.

Now connect transmitting antenna, using any insulated piece of wire from 50 to about 200 ft. long. Best bet is a single piece of wire 130 ft. long (including the lead-in), as high and in the clear

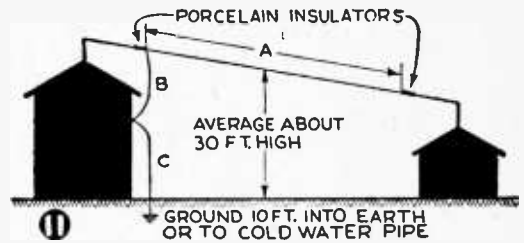

Antenna system suggested for the transmitter. Sum of A and B to equal 130 ft.; C as short and direct as possible. Receiving antenna is 25 ft. of hook-up or magnet wire around molding of operating room.

as possible (Fig. 11). A good ground (the cold-water pipe on the street-side of the meter, or a piece of pipe driven at least 10 ft. into moist soil), should also be connected to the B minus terminal of the unit.

For final tuning, first set the output (antenna side) tuning capacitor at maximum capacity and "peak" the plate-side tuning condenser with the neon-bulb. Then decrease the antenna-side capacitor in capacity slightly, meanwhile reapeaking the plate-side capacitor. Continue this process until the dial-lamp in the antenna lead glows



Place small parts and longer leads in the space under the baseboard (see Part 1).

with maximum brilliancy. (Don't expect it to gleam brightly. A just-perceptible glow may well be satisfactory, depending on the characteristics of the particular antenna in use.) Adjust both condensers carefully until you obtain this condition.

If an amateur-type absorption frequency meter is available, hold it near the transmitter tank coil. A strong indication should be noted at the frequency of the crystal, but none at any other setting. The transmitter is then "on the air."

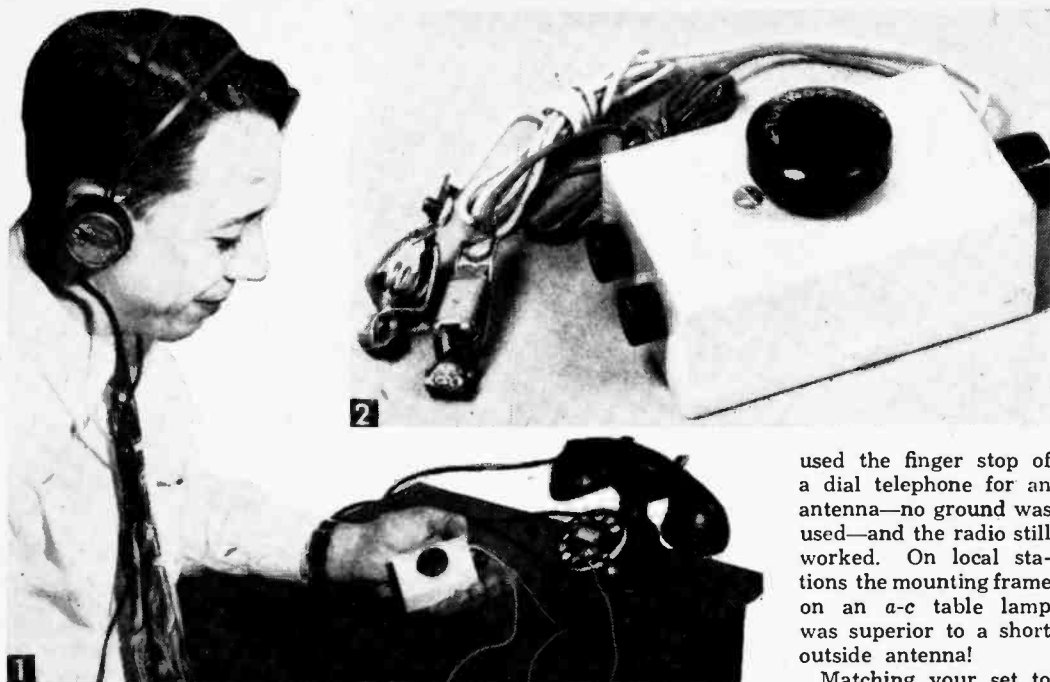

used the finger stop of a dial telephone for an antenna—no ground was used—and the radio still worked. On local stations the mounting frame on an a-c table lamp was superior to a short outside antenna!

Matching your set to the particular broadcast frequency heightens crystal reception. Don't hesitate to try all kinds of objects for picking up a signal. One good antenna

was a bed spring with the metal frame of a bed lamp as ground. Another good match were two grounds at different potentials—one a water pipe, the other, a copper line to a propane tank.

The final requisite for good reception is a pair of sensitive headphones. These should be magnetic headphones of 2000 or 4000 ohms resistance. Do not go on labels alone. Unscrew the caps from any headphones you plan

Super-Sensitive Vestpocket Crystal Radio

A "high-Q" antenna coil makes this set a real performer

By T. A. BLANCHARD

FAR from being a throw-back to the days when radio coils were wound on oatmeal boxes with doorbell wire, this tiny crystal set separates stations—without batteries or a complex circuit.

Aside from selectivity good crystal set results depend upon antenna and ground. For long-distance reception, use as long and high an antenna as possible. Where space is at a premium, the antenna may be installed in X fashion (Fig. 4). Use a cold-water pipe as ground, or in rural areas, a well pump pipe. However, we

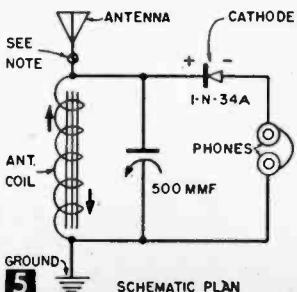
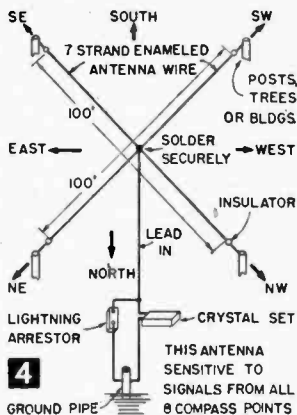
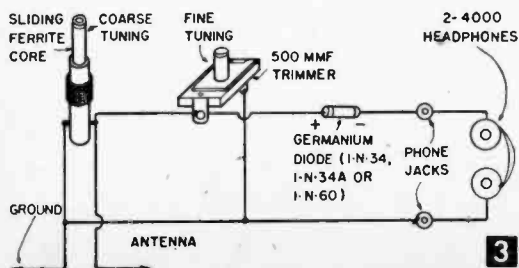

NOTE: Insert 100 to 500 mmi. mica condenser to tune in 1600 to 1000kc. stations when long outdoor antenna is used.

to purchase. If the metal diaphragms drop off, don't buy them. In good headphones the metal diaphragm sticks to the magnets. Any headphone with only a single coil inside the ear piece should also be passed up as unsatisfactory.

Now let's get to building the pocket crystal set. This set was assembled in a small plastic box measuring only $3 \times 1\frac{1}{8} \times 1\frac{1}{8}$ in. but it may be assembled in a metal or wood container of

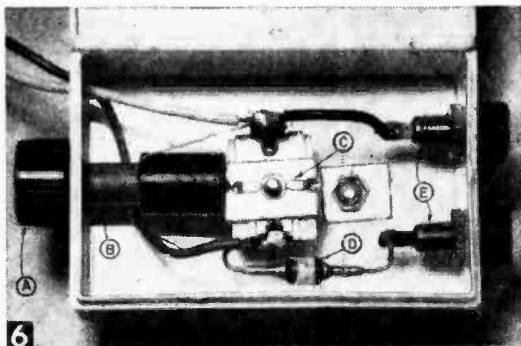

Arrangement of components inside plastic or metal case. (A) coarse tuning knob, (B) ferrite core antenna coil, (C) fine tuning trimmer capacitor, (D) germanium diode and (E) phone jacks.

any convenient size. Fig. 6 shows the actual assembly and if you follow connections, the case size is not important.

A ferrite slug-tuned type antenna coil is the reason this set is so highly selective. Sliding the ferrite core in and out of the coil accomplishes the same result as complicated wave-traps. Fine tuning is accomplished with the trimmer capacitor. Stations near the top of the dial (550 kc.) are tuned-in with the coil slug pushed in. Sta-

MATERIALS LIST—VESTPOCKET RADIO

- 1—Small plastic box (Safety razor case, cigaret box, etc.)
 - 1—Progressive wound antenna coil with adjustable ferrite core (Miller, Stanwyck)
 - 1—Mica trimmer condenser (500mmf or 600mmf max. capacity)
 - 1—Germanium crystal diode (1N34, 1N34A or 1N60)
 - 2—Earphone tip jacks (insulated or non-insulated type)
 - 2—PeeWee spring clips
 - 2—3-ft. lengths plastic hook-up wire (stranded)
 - 1—Pair sensitive magnetic headphones (2000 to 4000 ohm res.)
- Kits including all necessary parts for building this vestpocket crystal radio may be obtained for \$2.98 (postpaid) from ElectroMite, P. O. Box 636, Springdale, Conn.

tions near the bottom of the dial (1600 kc.) are tuned-in with slug pulled out. Both controls are, of course, individually adjusted for maximum reception.

A crystal set with these two great modern improvements—the germanium diode detector and the ferrite-tuned antenna coil—can fascinate even the fellow who thinks he's seen and heard everything. Our big kick comes from seeing how much we can get for free from two nearby transmitters representing the hub of the biggest U. S. networks—WCBS and WNBC. Both provide loudspeaker reception at no cost!

Through the years, the crystal radio has appealed to both kids and adults, probably because it combines a mysterious air of operating without external power and yet producing usable sound. This tiny set embodies miniature reproductions of the bulky components that went into the original sets years ago.

The old-time experimenter's chief conversation piece was his crystal detector. This detector was usually a dime-size lead casting with a piece of embedded galena, silicon, iron pyrites, or carborundum. Some aggressive crystal makers embedded a piece of each substance in a single lead mount so that the experimenter might "tickle" his catswhisker on each.

So that these rectifiers (crystal detectors) or as they are now known—crystal diodes, may be preserved for posterity, here are some simple explanations of these mineral bits of magic:

Fool's Gold. If you live where coal is mined you know it by this common name. Actually it is either iron sulphide or iron pyrites.

Carborundum. This is a compound of carbon and silicon made by electric furnace fusion.

Germanium. This element is today's best known rectifier and now used in TV, high frequency, and modern crystal sets. Germanium may eventually replace most radio tubes as used in transistors, patents of which are owned by Western Electric Co. Germanium was discovered in 1885 by Prof. Winkler near Freiberg, Germany. In appearance, germanium resembles tin, but has the rectification properties of crystals.

There are probably still undiscovered compounds with even greater virtues than germanium. While mentioning all popular crystal detectors, let's not forget the most popular old-time mineral, Galena.

Galena is native lead sulphide found in the Kansas, Missouri, Oklahoma tri-state area. Of all detectors (including Germanium) we have found this mineral the best detector for crystal radios.

Of course, galena requires a "catswhisker" detector, and, as this is not a fixed-stable unit, the set described here employs Germanium type.

Solder Clipped to Iron Cord

• You'll have no trouble keeping track of rosin core solder if you will purchase a trouser clip at a bicycle store, slip it over the iron cord and wind

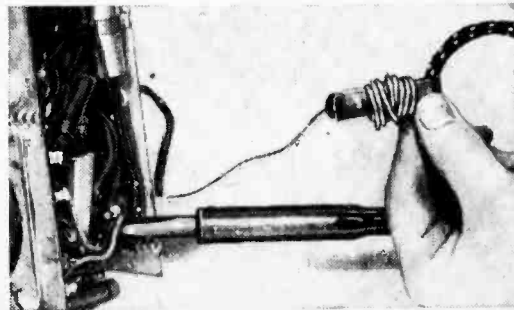

solder around clip so it can't come off.—H. L.

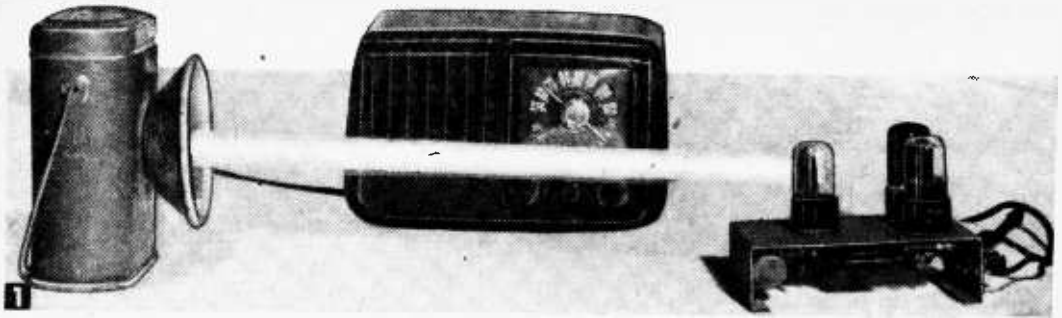

Program from radio is converted to light beam and sent via Delta lantern to photo-electric receiver at right. Proper spotlight or light source will transmit close to $\frac{1}{4}$ -mile. Beam is painted in here to clearly indicate action.

Talking on a Light Beam

AMAZING as the feat of talking over a light beam may seem, the idea is not new. For some 25 years movie sound reproduction in your local theater has been accomplished with a phototube and light beam. Running along the edge of the film is a narrow "sound track." The track contains little zig-zag streaks of varying lengths, or a ribbon-like strip varying from opaque to nearly transparent. As the sound track passes between light beam (exciter lamp) and photocell, the light striking the phototube literally "flutters." This "flutter" is the modulating medium—whereby a flickering light stream is converted into voice or music!

This is the same idea employed in this radio experimenter's model. However, modulation is accomplished entirely by electrical principles whereas movies are mechanically modulated, as by film. You'll find this light beam transmitter easy to construct, since a small table radio may be incorporated in its design (Fig. 1). In order to convert the sound that usually comes out the speaker to a modulated light beam, you need only disconnect the speaker and install a concentrated spotlight in series with the set's output transformer (Fig. 2).

The two uncovered copper wires from the output transformer are disconnected from the PM speaker cone. Solder two extension leads to these wires so that the secondary of the radio transformer may be wired in series with a battery operated light source (an ac light source will not

Radio experimenters can now build this simple transmitter, which broadcasts over a light beam through an ordinary radio receiver

By THOMAS A. BLANCHARD

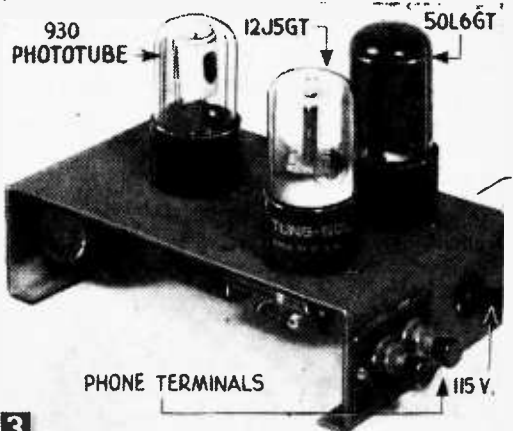
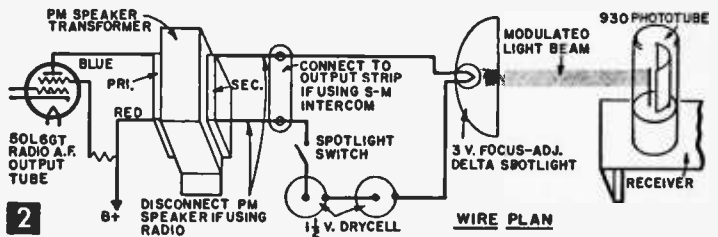

Light beam receiver is assembled on simple two-fold metal chassis for easy wiring.

work!). With spotlight switch closed, and radio tuned to a station, the bulb will flicker madly. Now when this beam is aimed on the phototube in the light beam receiver, you will hear the program from the radio set—via light beam!

The ac impulse from the output transformer primary adds to or subtracts from the 3-volt battery voltage, which causes the

bulb's light output to vary at the same frequency as the applied signal (or, in other words, the impulse bucks the reactance effect of the secondary winding, causing light modulation). The radio output transformer operates like an ultra-high-speed rheostat in the spotlight circuit, causing the light intensity to vary faster than the eye can see these changes. To transmit your voice over the radio, attach a mike and preamplifier into the radio phono connection. Better yet, you can use a home broadcaster mike (modulated oscillator type) available from radio supply houses.

You may find that you need to modify the secondary winding of the output transformer. For example, if the light intensity is too bright with no noticeable "flutter," more turns of #26 magnet wire should be added. On the other hand, if spotlight is too dim, remove some of the turns from secondary winding.

Rather than mutilate the set's transformer (which is often clamped to the PM speaker frame) it is best to buy a separate transformer (they cost little) for the 50L6-tube. To add or subtract secondary turns, simply remove the mounting strap, lifting the "E" lamination out of the core. You'll find the secondary winding directly under the outer paper insulation. If this insulation is carefully cut with razor blade, it may be replaced with a strip of Scotch tape after alterations.

The range of this light beam transmitter depends on the light source's efficiency. By employing optics rather than parabolic metal reflectors alone, you can improve both the range and concentration. For long-range use, the receiver will respond better if an optical condensing lens is placed in front of the phototube (a Boy Scout's "burning" lens is excellent for this purpose). Position and focus the lens so the con-

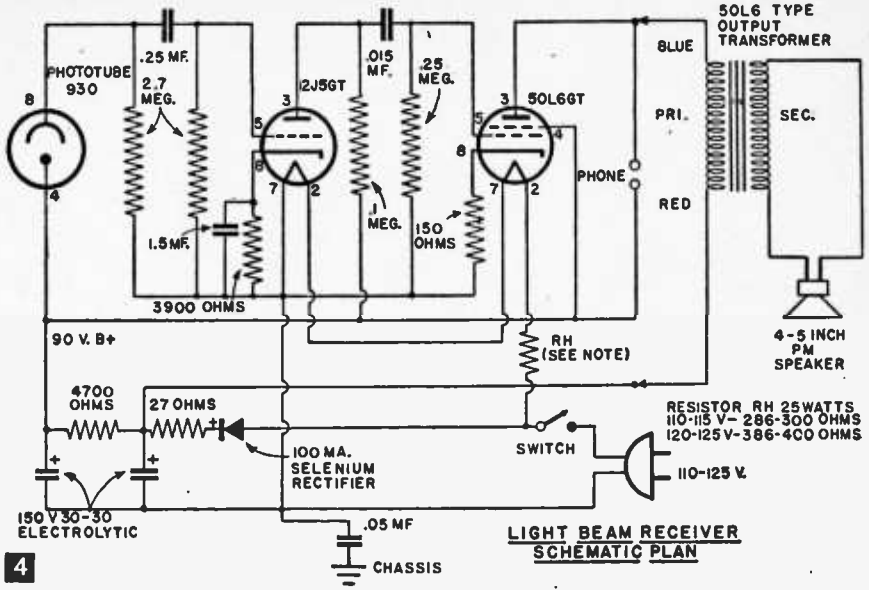

LIGHT BEAM RECEIVER SCHEMATIC PLAN

MATERIALS LIST—LIGHT BEAM RECEIVER

- 1 pc. #14 or 14 gage aluminum or c.r. steel, 3/2" x 9"
 - 1 type 930 RCA phototube
 - 1 type 12J5GT RCA triode tube
 - 1 type 50L6GT RCA pentode tube
 - 1 4-5" PM speaker and output transformer (optional)
 - 1 Delta spotlight (3 or 1 1/2 v. model)
 - 1 100 ma. selenium rectifier
 - 1 pair phone terminals
 - 3 octal tube sockets
 - 1 length fixture cord, plug and switch
- RESISTORS**
- 2 2.7 megohm, 1/2 watt
 - 1 0.1 megohm, 1/2 watt
 - 1 0.25 or 0.27 megohm, 1/2 watt
 - 1 4700 ohm, 1 watt
 - 1 27 ohm, 1 watt
 - 1 3900 ohm, 1 watt
 - 1 150 ohm, 1 watt
 - 1 25 watt wire-wound resistor 300 to 400 ohms (see text)
- CAPACITORS**
- 1 30-30 or 40-40 mfd., 150 v.v. electrolytic
 - 1 1.5 (or 2) mfd., 200 v.v. paper capacitor
 - 1 .25 mfd., 200 v.v. paper capacitor
 - 1 .05 mfd., 200 v.v. paper capacitor
 - 1 .015 (or .02) mfd., 200 v.v. paper capacitor
- Miscellaneous hardware as needed

centrated light from distant electric lantern is concentrated in the center of phototube's cathode and anode elements. You can enclose the phototube amplifier in wood or metal box to keep out stray light.

Building the Light Beam Receiver

The light beam receiver (Figs. 3 through 6) uses only standard radio components and its circuit (Figs. 4 and 6) follows the same basic design used for movie sound reproducers, except that it uses tubes designed for operating on low plate voltages. Thus the receiver needs no power transformers of any kind.

As shown in Fig. 6 the receiver chassis is just 9 in. long x 3 1/2 in. wide aluminum or steel. Each end is bent up 1 1/2 in. to form the amplifier foundation. Ample room is available so that socket and mounting holes need not follow any precise

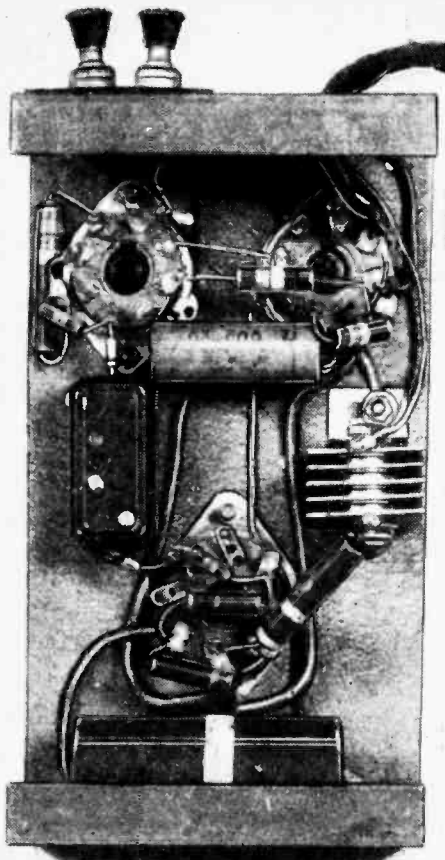

5

Bottom view of light beam receiver.

layout. Assemble the receiver components shown in the materials list, and wire and solder carefully using only rosin core solder. Only pins #4 and #8 are used on octal phototube socket. (Fig. 6).

The 12J5GT socket has no connections on pins #1, #4 and #6, while on the 50L6GT, pins #1 and #6 are blank. While it is common practice in ac-dc type circuits to return all grounds directly to the chassis, this is dangerous unless the metal chassis is completely enclosed in a plastic housing so that it is impossible for the chassis to be touched. To avoid this danger, use a heavy piece of tinned copper wire, isolated from the chassis, for all negative junctions. A .05 mf. capacitor is used to harmlessly ground the chassis to the isolated copper buss wire (note left side of Fig. 6). To make the copper buss wire rigid, you may solder it to pins #1 of the 12J5, 50L6 and 930 phototube sockets. This will provide a convenient zig-zag route to which the various resistors and capacitors may be terminated. For editorial clarity, this buss has been shown in a straight line and reader may adhere to the Fig. 6 diagram.

Since the Light Beam Receiver derives both its ac tube heater (filament) and plate-screen grid voltages (rectified dc 90 v.) right from the power line, certain consideration must be given

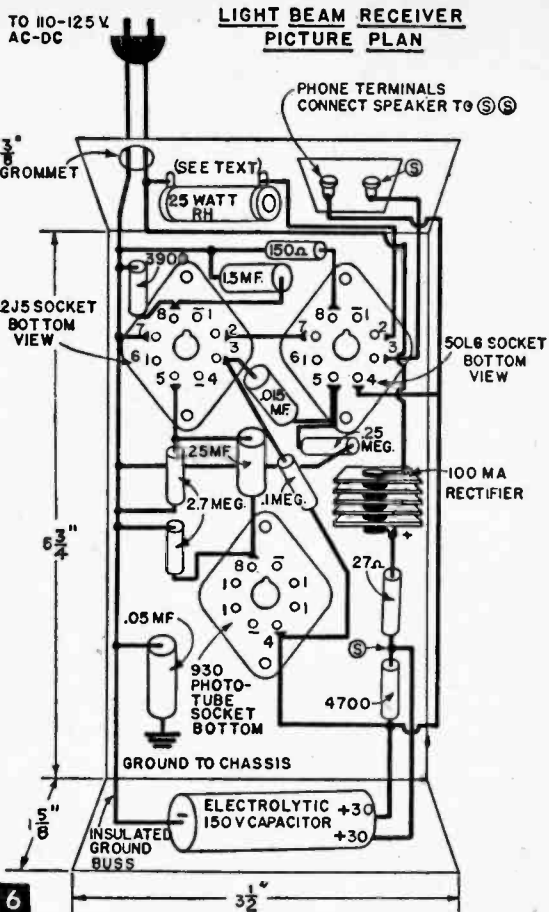

6

to the line-drop resistor ("RH" in Figs. 4 and 6) although any moderate increase of the rectified dc potential is not important. Check with your local power company as to the "peak" line voltage delivered to your home. If this peak is never in excess of 115 volts (any cycle), the value of RH may be 286 to 300 ohms. If, however, the "peak" is 125 volts, the line drop resistor must be higher, or 386 to 400 ohms. If the 25-watt resistor RH is not high enough to handle peaks, burned out tubes will result. If in doubt, use the largest resistance, since the light beam receiver will still operate on a reduced "heater" voltage although the warm-up time will be somewhat increased.

The receiver, correctly wired, will provide moderate loudspeaker volume and excellent ear-phone reception. Speaker transformer is connected to the "phone" terminal (S) and to B plus between 27 and 4700 resistors marked (S) in Fig. 6. For greater volume, you can try connecting phone terminals to a separate amplifier. Don't attempt to increase range of transmitter with, say, a 6 volt battery and an auto spotlight bulb. Any but "flashlight-type" bulbs are of the coil-filament type, and residual glow causes them to react too slowly to the output transformer's modulating action to be useful here.

Extension Speaker

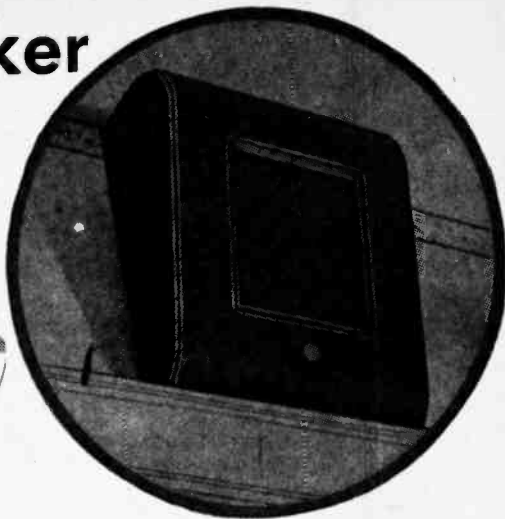

Wall baffle mounted over door..

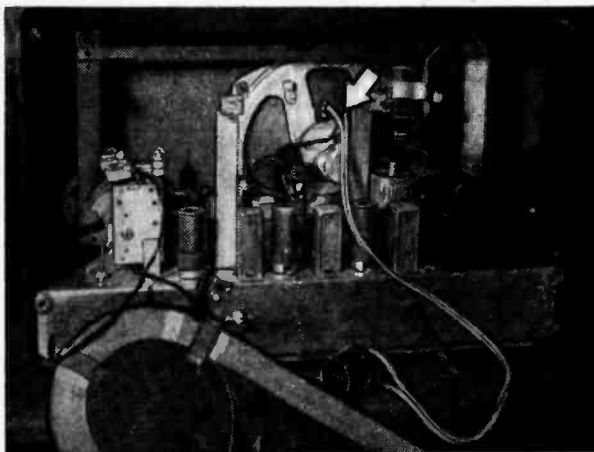
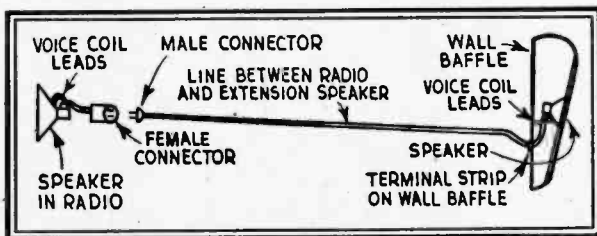

Connection to voice coil. Arrow points to leads.

LISTENING to radio programs in a noisy kitchen, or the cellar, darkroom, laundry or playroom, isn't easy if the radio is located in another room. But one radio can serve 2 locations with the addition of another speaker.

For about 30 minutes of your time and something less than \$8 (or, if a homemade baffle is used, less than \$5), you can install an extension loud speaker at any location within about 25 feet from the radio. You'll need a good quality

5 in. PM speaker, with as large an Alnico V magnet as you can obtain, a wall baffle of the proper size for the speaker, a length of ordinary lamp cord to reach from the radio to the baffle, insulated staples for fastening connecting wire, picture hanging wire, a nail, and a 2-contact male and female cord connector.

Remove back cover from radio. Locate leads from voice coil which come from the cone close to the magnet and terminate on an insulated strip. Cut a piece of lamp cord long enough to reach from this strip to a point about a foot outside of the radio. Solder 2 wires from one end to voice coil terminals on insulated strip. To other end of wire attach female cable connector. Replace back cover of radio. These connectors allow you to detach line from the set so it can be moved.

Now mount your speaker unit with the wall baffle. With a short piece of lamp cord, make a connection between voice coil terminal strip and a dual terminal strip mounted on wall baffle. Plug in connectors and turn on radio to check the operation. After checking, turn off radio and disconnect the wire while you attach speaker. If you install it over a door, you can rest baffle

on top of door frame. Drill a nail part way into wall at the appropriate spot and use picture frame wire to support wall baffle in position. Adjust wire length to allow top of baffle to tilt slightly downward.

Starting at the radio end, fasten connecting wire along baseboard and door frame with insulated staples. Then cut end of wire nearest wall baffle to proper length and connect it to the terminal strip.—WILLIAM MARON.

T. V. Antenna Coupler

You can operate two or more TV sets from a single roof antenna by means of this simple R.F. coupling transformer

By T. A. BLANCHARD

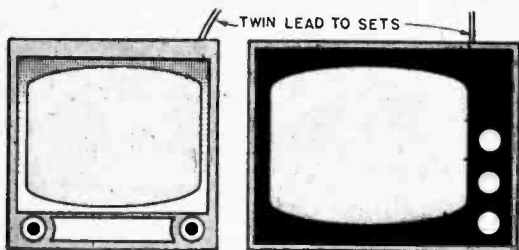
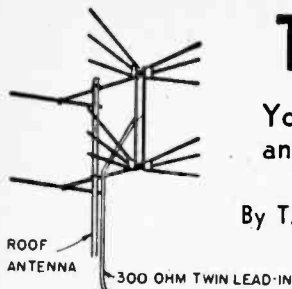

IF YOU have two television sets, this simple coupling device will enable you to operate them from a single roof antenna. Fig. 1 shows a two-set coupler; however, by constructing four R.F. coupling transformers as shown in the schematic (Fig. 2), 3 or 4 sets can use the same antenna.

Actually, when several sets are operated off a single antenna, performance is often better than that obtained with a separate antenna on the roof for each set. The coupler reduces interaction between TV sets operated in close proximity of each other. Tests with this unit showed no loss in signal strength either at the high end (Channel 13) or low end (Channel 2) of the TV bands.

The aluminum panel (Figs. 1, 3 and 4) is slotted to clear the soldering lugs of a 2- and 4-screw terminal strip. The R.F. coupling coils are wound on a single coil form for convenience and

soldered to the terminal lugs in self-supporting fashion (Fig. 3). A coil form salvaged from a discarded I.F. transformer is long enough for both, or they may be wound on individual forms of $\frac{3}{16}$ in. diameter.

The primary and secondary windings of the R.F. couplers (about 30 turns each) are both wound in a single operation. Cut off two 34 in. lengths of magnet wire, and dip the ends of one piece in colored nail polish. When dry, secure an end of each wire in a small hole pierced in the coil form. Apply Duco or similar cement to the coil form and wind the dual lengths of magnet wire in a tight, even layer. Allowing $2\frac{1}{2}$ in. of wire at the end for making connection to terminal lugs, anchor these leads in another pierced hole and set coil aside until cement has set.

Wind the second R.F. coupling transformer in the same manner. When both coils are dry, scrape insulation from the ends of the plain wires and solder to the 4-post terminal strip as shown in pictorial plan (Fig. 4). The primary wires are easily identified by the nail polish. Scrape the insulation from the right-hand red-tipped leads of each coil. Twist these together

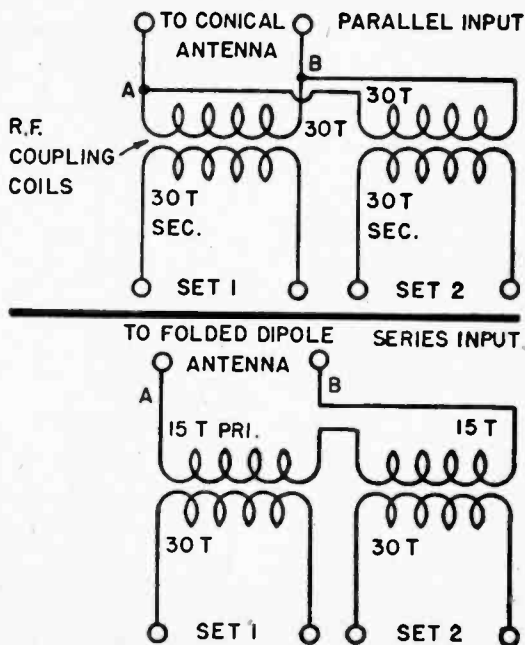

UP TO 4 TV SETS MAY BE ATTACHED TO CONICAL ANTENNA USING ABOVE CIRCUIT IN TANDEM

2 SCHEMATIC PLANS

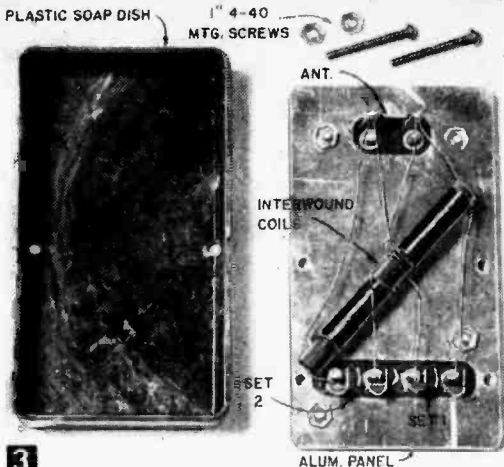

3

MATERIALS LIST—TV ANTENNA COUPLER

- 1 plastic soap case (dime store)
- 1 aluminum panel, 2 3/8 x 4"
- 1 2-post terminal strip
- 1 4-post terminal strip
- 1 1/4 lb. spool #28 enameled magnet wire
- 1 length 3/16" dia. paper or plastic tubing or wood dowel
- 2 1" 4-40 machine screws with matching nuts

and solder to one of the lugs of the 2-post terminal strip. Now scrape off insulation from the two remaining red-tipped coil leads, twist together and solder to remaining terminal strip lug.

After attaching panel to plastic box with two 1 in. 4-40 machine screws and nuts through bottom of the plastic box, the coupler is ready for use. Attach set lead-in to the 2-post terminal strip. Run a short length of 300-ohm lead-in from first set to terminals marked Set 1 on coupler. A longer length of lead-in is then connected from Set 2 on coupler to the second TV set.

The coupler hook-up illustrated is for use with conical or X-type antenna only, which will match any lead-in wire and input (balanced or unbalanced) of any TV set. However, this coupler hook-up should be used only with sets having a 300-ohm input.

The primaries of the coupling coils are connected in parallel. This cuts the input to about 150 ohms for the 2-set coupler, and down to 75 ohms when a 4-set cou-

PLASTIC SOAP DISH
1" 4-40 MTS. SCREWS
ANT.
INTERWOUND COILS
SET 2
ALUM. PANEL

2 3/8 X 4" ALUMINUM PANEL

pler is employed. There were no noticeable objections to this, but two series units in tandem are best.

If you wish to invest a little more time for a more closely matched antenna input, carefully unwind 7 1/2 turns from each end of the primary coils. This will leave a 30-turn secondary with a 15-turn interwound primary in the center. Now connect the end of the first coupler primary to one of the 2-post terminal strip lugs. Solder the remaining end of this coil to the start end of the second coupler primary. Now solder the finish end of the second coil to the remaining terminal lug. The coils are thus wired in series to provide a 300-ohm match approximately. This hook-up is advised when using the 2-set coupler with a folded dipole or dipole type antenna requiring connection to a 300-ohm input.

To operate sets with 72-ohm coaxial fed inputs, a single coupler transformer with a tapped secondary winding will provide a match to the popular 300-ohm twin lead and conical antenna. Wind a coupler coil with two lengths of magnet wire as previously described. After winding 15 turns, twist a small loop in the red-tipped wire, and complete the windings.

Unwind turns from each end, leaving 15 turns with the loop-tap point in center. Connect the 30-turn coil to antenna posts on coupler. Connect one end of 15 turn coil to first screw of 4-post strip. Clean insulation from tap and solder to terminals 2 and 3. Connect remaining end of coil to terminal 4.

When attaching sets with coaxial lead-in to this coupler, the outer cable shields connect to terminals 2 and 3. The inner insulated wires connect to terminals 1 and 4, respectively.

Where a make-shift or hasty 2-set installation is desired, we suggest capacity coupling. Connect the roof antenna to the weaker of the two sets. Now attach a length of 300-ohm twin lead-in to the second set, and tape 3 or 4 feet of wire parallel with the roof antenna lead-in. Although there is no actual connection between second set and roof antenna, results are frequently very satisfactory.

Plastic Crochet Hooks Make Radio Dial-Cord Tools

• When installing radio dial-cords, use plastic crochet hooks for getting into difficult places. Remove the hook on one end and saw a slot, as shown. The slot fits over the cord so the cord can be moved around. Heat and bend ends of the plastic rod to angle needed.—A. TRAUFFER.

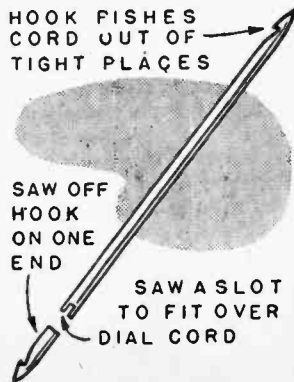

4 PICTORIAL PLAN

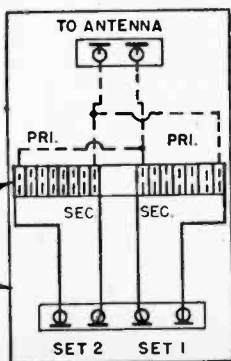

Remote Control with Selsyn Motors

Tune your radio from your favorite chair, find out which way the wind blows without leaving the house. These motors make it possible

By THOMAS A. BLANCHARD



Author demonstrates how one Selsyn follows movement of mate.

THERE is nothing on the market that will provide as much electrical fun and practical use as a pair of selsyn motors.

The selsyn motor gets its name from the word *self* in a now obsolete English usage—meaning *same* or *identical*—and the Greek word *syn*, which means *together*. Thus selsyn means 2 identical things that work together.

The selsyn motors pictured here are surplus from military aircraft; you can probably buy a pair of them for less than \$10. The two G.E. type 2J1G1 units used were designed for a 57½ v. 400 cycle ac power source, but they may be operated on 110-125 house current, which is only 60 cycles. While many 400 cycle devices will burn up on 60 cycle current, these G.E. selsyns did not get as warm as a conventional small motor when left connected for an hour to the power supply. The uses here require only intermittent attachment to 110 in most instances.

When 2 selsyns are connected together each will imitate the action of the other. Connect them to a power line, then turn the shaft of one selsyn. Instantly, the other selsyn's shaft will rotate to the exact extent as the shaft you rotated manually. Now reverse the set-up and turn the shaft of the other selsyn; the shaft of the first selsyn will follow your every move. Thus, either unit can be a *transmitter* or *receiver* of mechanical movement. The remote control possibilities of these little devices are obvious.

Selsyn units are supplied by surplus dealers minus the female AN connector, which resembles a giant radio tube base. This similarity was the key to a simple and convenient means for connecting the 5-wire cable needed to operate the units. The end of the selsyn has 5 coded pins. Soldering wires to these pins may be difficult,



or harmful to the unit. But as the pins are identical to GT radio tube pins, in diameter, we took a couple of discarded octal wafer radio tube sockets apart and used the metal connectors for cable terminations. These snap or slide on or off the selsyn motor pins with ease. Solder them to the 5-wire cord.

A regular 60 watt Mazda lamp provides the most economical voltage dropping resistance, both in operation and initial cost. When a more compact resistance is desired, use a regular radio type 150 or 200 ohm wire-wound resistor rated at 20 watts, and provide good ventilation for this re-

Connections for Selsyn Motors

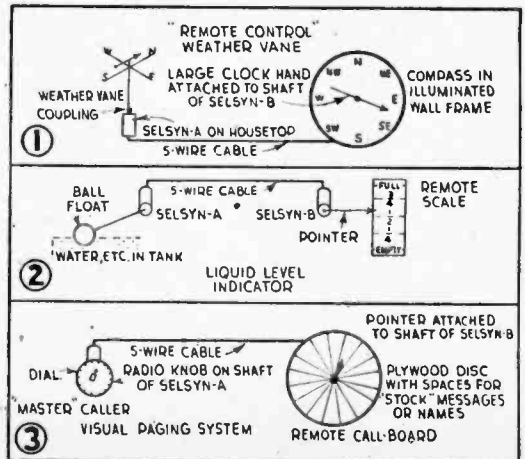

SOURCES OF SUPPLY—2J1G1 SELSYNS

- Name and Address
 Instrument Associates Dept. J, 37 E. Bayview, Great Neck, L. I., N. Y.
 TAB Electronics, Selsyn Div., 6 Church St., N. Y. 6, N. Y.
 Pioneer Surplus Co., 331-M Canal St., N. Y. 13, N. Y.
 G & G Radio Parts, 51-A Vesey St., N. Y. 7, N. Y.
 Palley Supply Co., Dept. G, 10460 S. Vermont Ave., Los Angeles, Calif.

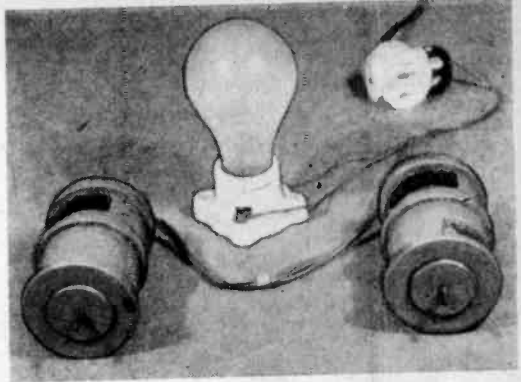

A pair of S1.98 Selsyn motors operating in series with 60 watt Mazda bulb is ready for workbench trial and experiment.

sistor. If selsyns are separated by some distance, the lower resistance value—150 ohm resistor or 75 watt lamp—may insure greater torque. At short distances, these lower values will give the units more driving power, but if there is any indication of motor frames becoming too warm, replace with the higher 200 ohm resistor, or the 60 watt lamp.

To protect the selsyn unit from atmospheric action, when used outdoors, cover it with a hood. A tall evaporated milk can is ideal, since it has

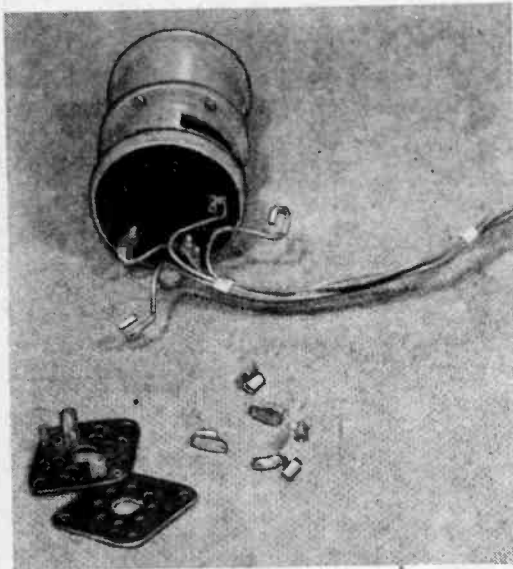

Old radio tube sockets provide perfect cable connectors for Selsyn motor pins. Break tube socket and remove the phosphor bronze clips. Solder clips to ends of 5-wire cable.

no flange in which rain can accumulate. Avoid fruit and vegetable cans which have flanges. Cut off top of can with tin-snips and pierce a hole in center of bottom. Ream hole to 1/4-in. dia. and insert a rubber radio grommet. The grommet hole will make a snug weather-tight fit over the selsyn shaft. To prevent hood from rusting, paint inside and out with auto-top dressing or asphalt roof paint.

A few of the selsyn's uses are described below.

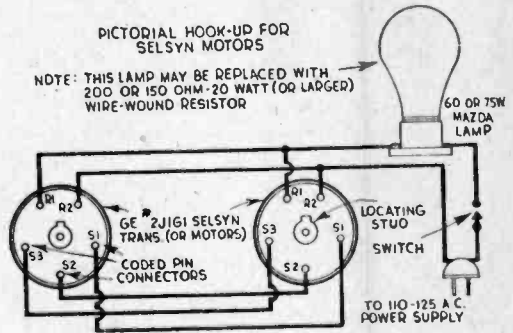

Others will occur to you according to your needs.

1. *Remote Reading Weather-Vane.* Mount selsyn A on the roof-top. To its shaft (which is provided with a 6-40 thread) attach a weather vane. Run a special 5-wire outdoor-type cable to selsyn B. Attach a large clock hand to the shaft and mount unit in a frame carrying a reproduction of the compass points. Many of your auto road maps are illustrated with compass designs. Have a photocopy made in a suitable size, color the photocopy and install a 60 or 75 watt voltage drop bulb inside the frame to make a beautiful illuminated weather vane.

2. *Liquid Level Indicator.* Water, oil, etc., in storage tanks may be checked from distant points by fitting a copper ball float (as used in bath equipment) to shaft of selsyn A. Fashion pointer from sheet metal, or attach a regular clock hand to selsyn B. Make a calibrated remote scale for pointer, to indicate contents of tank from empty to full.

3. *Visual Paging System.* There are many places where the electronic "intercom" loud-speaker call system is worthless—boiler works, for example, or mills, farms, etc., where the persons being paged move about constantly. Fit selsyn A with an identification dial and radio pointer knob. Place selsyn B behind a large masonite or plywood dial divided into a suitable number of divisions for "stock" messages or individual's names. A large clock hand attached to selsyn B

will move to proper division on remote call board when the office clerk positions his *Master Caller* pointer to desired person or message.

A colored code-light system may be substituted for call board simply by removing the ball bear-

ing stop from a Mallory tap-switch so the switch turns from tap to tap without effort. Each tap turns on a different colored bulb assigned to a certain employee. A commercial outfit doing the same thing may cost up to \$1,000.

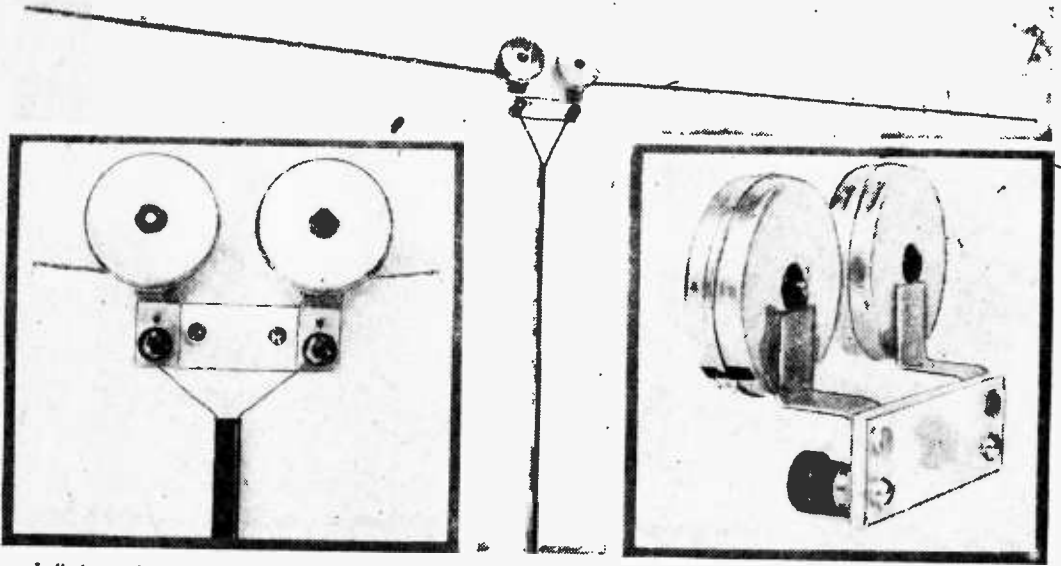

Left, front view of larger di-pole; right, rear view. Center, the large di-pole on the wall of the author's den. The elements are pulled out to 24 in. for the high end of the 88-108 megacycle FM band.

Portable Di-Poles for TV and FM

Here's how you can make a set of adjustable di-pole antennas

By ARTHUR TRAUFFER

HERE are just about the most compact, thoroughly portable and adjustable FM and television di-pole antennas ever developed. Both of these di-poles use common "roll up" steel tape rules, and the tapes themselves serve as the di-pole elements. When using the larger tapes, the elements or rules can be pulled out to any desired length up to 6 ft., and they will stay out until pressure on the release buttons snaps them back into the cases. Since the rules are calibrated in fractions of inches, you can easily balance each element electrically, that is, get both elements exactly the same length. It makes little difference whether the di-pole elements consist of tubing, solid rod, wire, or tape. The important thing is that the elements be metallic, and both the same length.

For portable FM and television receivers, these di-poles are ideal.

With the larger di-pole, the elements are self supporting up to 36 in., but beyond this, it is necessary to support the elements with string or other means. The smaller di-pole was intended for use with frequencies from 100-megacycles and up. The elements can be drawn out to

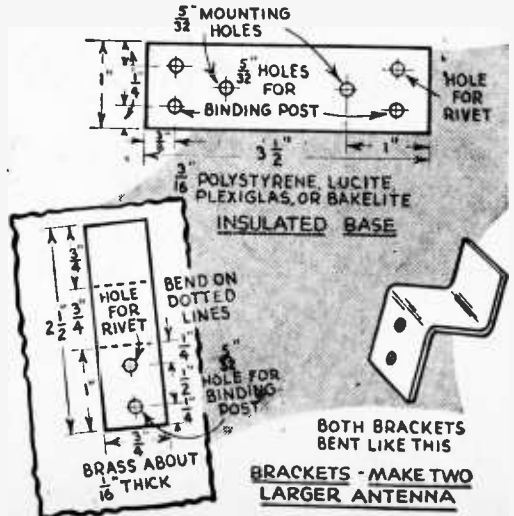

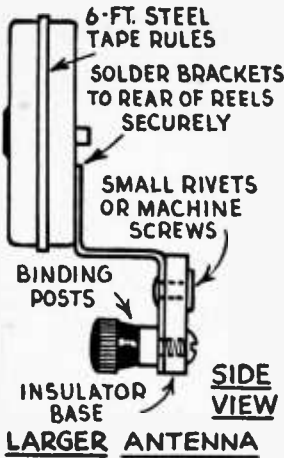

MATERIALS LIST — PORTABLE DI-POLE ANTENNAS

Large Antenna

- 2—8 ft. Walsco metal-encased steel tape rules—about 45c each in all dime stores.
- 1—Length of 1"x $\frac{1}{2}$ "x12" Polystyrene strip—about 40c in radio stores. Sold only in 12" length. Lucite or Plexiglas can be used.
- 2—ICA Bakelite binding posts, about 12c each.
- 2—Flathead tubular rivets. Brass or copper about $\frac{1}{16}$ " long. Sold in auto stores, or can be had in auto repair shops.
- 1—2"x3" piece of sheet metal for angle-brackets. Brass or steel about $\frac{1}{16}$ " thick.

Small Antenna

- 2—"Little Pal" 3 ft. Walsco metal-encased steel tape rules. 20c each in dime stores. Polystyrene strip listed above can be used if desired, or buy a 12" strip $\frac{3}{4}$ "x $\frac{1}{16}$ " for about 30c.
 - 2—Roundhead machine screws with hex. nuts, 6-32 $\frac{3}{4}$ " long.
- Note: Polyethylene ribbon twin-lead for above antennas can be any length within reason. 300 ohm twin-lead sells for about 3c per foot. Prices listed above are approximate.

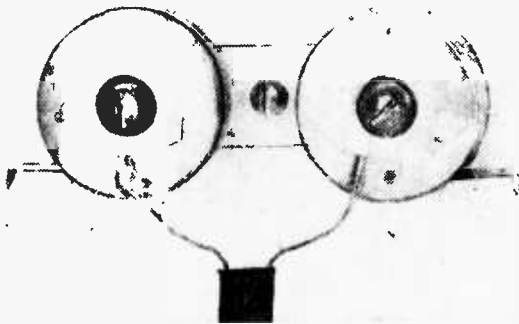

36 in. and they are self supporting up to 24 in. As the smaller steel tape rules contain no mechanism for locking the tapes when extended, it is necessary to push a small wedge between the tape and the opening in the case after the tapes are extended (wooden matches will do).

For the larger di-pole, mount the tapes on brackets with two bends in them in order to hold tapes out far enough so you can get at one of the tape-release-buttons with your finger. Use any good insulating material, Polystyrene, Lucite, Plexiglas, or Bakelite, for the insulator base, remembering that strength is perhaps more important than dielectric qualities because center of di-pole is at a low voltage node. A binding post and a small flat-head tubular copper or brass rivet hold each bracket securely to the insulator base. Binding posts make electrical contact with the tapes through the brackets

When attached to the rear of the radio-phonocombination console, the antenna is almost hidden, the elements are easily adjusted for length, and the elements can be made to disappear when the cabinet must be moved.

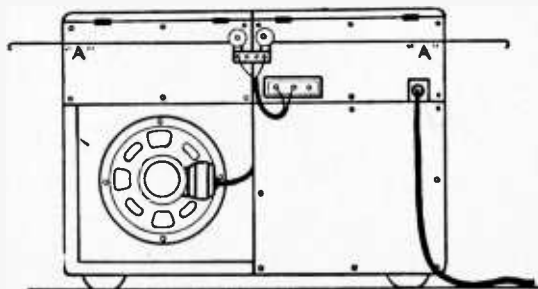

SMALL INSULATED BRACKETS MOUNTED AT "A" ON CABINET WOULD PREVENT SAG IN THE TAPES WHEN EXTENDED

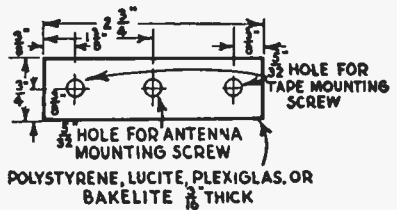

INSULATED BASE - SMALLER ANTENNA

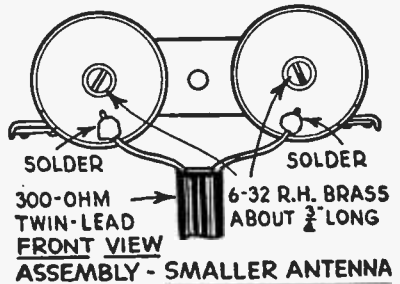
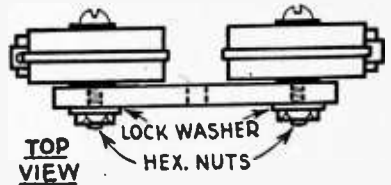

which are soldered to cases of tapes. A 300 ohm ribbon lead-in is used to connect di-pole to antenna input of receiver. After holes are drilled in the bases, di-pole can be mounted on rear of receiver, on the wall, or onto a stake which has been driven into the ground. Wood-screws or machine-

SAVE MONEY

TEST YOUR OWN RADIO AND TELEVISION TUBES AT HOME!!!



(Patent Pending)

SIMPLE EASY!

E-Z

Conductance

TUBE TESTER

ONLY

\$4.98

- No Tube Manual or Knowledge of Electronics Necessary . . .
- Tests Old and New Tubes Accurately for Direct Opens, Shorts & Burn-Outs . . .

Unique system of plug-in test cards show exactly what to do to each tube to test for opens, shorts and burn-outs which account for over 90% of tube failure. Simple and easy to use! Over 5,000 now in use! Order now!!!

MONEY-BACK GUARANTEE!

NEW! E-Z Condenser Tester
Test for Shorts, Opens, Intermittents, Check Capacity. Handy and efficient!!! **\$6.98**

Order C.O.D. and pay postman \$4.98 plus postal charges. Send check, cash or M.O.. we pay postage.

E-Z TESTER CO. (DEPT. R) MACON, GA.

HOME TV SERVICING THIS EASY WAY

SHOOT TV TROUBLE FAST

With H. G. CISIN'S "TV DOCTOR"

Shows how to fix your own set rapidly and SAFELY!
YOURS TO TRY 5 DAYS FREE
Save money, throw away service contracts. Here's a real "fix-it-yourself" book written in language you can understand by a noted TV expert.

TUBES CAUSE 85% OF TV TROUBLES

The TV DOCTOR shows you how to locate and change all defective tubes in your set with complete safety.

WITHOUT EXPERIENCE—PICTURES AND TEXT MAKE FIXING IT YOURSELF EASY!

Reveals many closely guarded TRADE SECRETS. Lists over 123 trouble conditions. Method applies to ALL TV SETS even newest RCA, Philco or any of 2000 models old or new. Copyrighted TROUBLE SHOOTING GUIDE pin-points hundreds of troubles. ELEVEN (11) money-saving, fact-cramped, detailed, profusely illustrated chapters include: exactly how to locate tube or part causing trouble; practical ways to combat interference and ghosts; how to appraise and buy a better TV set for less money; how to install the best antenna for your location; also valuable information on wave traps, lead-ins, color TV, names & addresses of TV mfgs.—a veritable encyclopedia.

Save Expensive Service Calls
Be Assured of Continual TV Pleasures
Only \$1—You'll Say It's Worth Hundreds!

\$1
SPECIAL OFFER: A new "TV PICTURE GUIDE" with illustrations, explaining "TV Terms" and selling for \$1; H. G. Cisin's famous "TV TROUBLE SHOOTING METHOD" which trains you to be a TV DIAGNOSTICIAN & TV SERVICEMAN. Acids for \$1—PLUS the "TV DOCTOR"—all 3 for only \$2 postpaid. You save \$1.

RUSH COUPON: Enclose \$2. Five days to read without risk or return for refund.

H. G. Cisin, Consulting Engineer
Department SM-4
200 Clinton St., Brooklyn 2, N. Y.

Enclosed find \$2 full payment for "TV DOCTOR," "TV TROUBLE SHOOTING METHOD" & "TV PICTURE GUIDE"—rush all 3 postpaid.

Enclosed find \$1 in full payment for "TV DOCTOR." Rush copy postpaid.

Name _____
Address _____
City _____ Zone _____ State _____

ORDER NOW POSTPAID

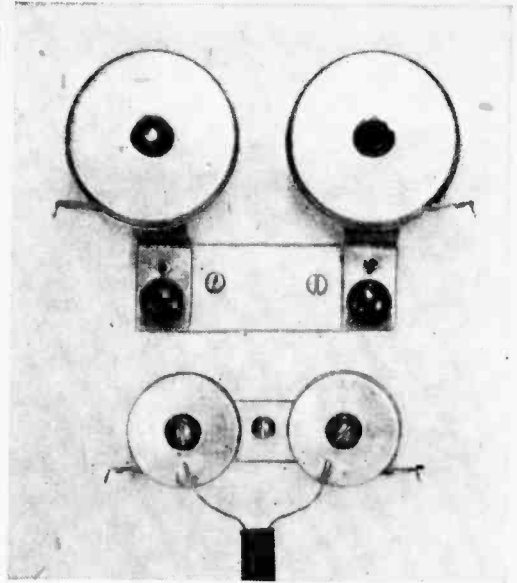

The large and small di-poles photographed together to give size comparison.

screws are used depending on where you mount the di-pole.

In constructing the smaller di-pole, since there are no tape-release-buttons on these small tapes, it is not necessary to mount the tapes on brackets; tapes are simply attached to insulator base with two round-head brass machine-screws, lock washers, and nuts. Then solder 300 ohm ribbon lead-in directly to tape cases as shown. After tapes have been drawn out to the desired length, lock them in position by pushing a match into the opening of each tape case. Tapes will snap back into cases again when matches are pulled out. Both the larger and the smaller tapes used by the writer are made by a well-known firm and they are sold in all dime stores.

Soldering Iron Holder

- Make a simple soldering iron holder from 1 x 1/8 in. strap brass, fastening it to back of workbench on a sheet of asbestos paper with rh wood screws and washers. Holder should keep iron about 2 1/2 in. away from bench. Device keeps iron handy, and vertical position allows tip of iron to heat faster and handle to stay cooler.—ARTHUR TRAUFFER

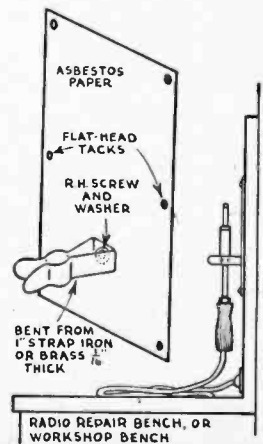

Tapped Coil Crystal Set

THIS easily constructed crystal receiver which uses few parts, needs no power supply, has a minimum of adjustments, and will give clear reception over a limited area. It is designed to give maximum selectivity in metropolitan areas where several high-powered radio stations may be found. Where *selectivity* is not necessary, you can adjust this set to provide maximum *sensitivity* by placing extra taps on the secondary winding while constructing the coil, as we will explain later.

The receiver may be mounted on a board $4\frac{1}{2}$ by 6 in. or it may be placed with the earphones in a cigar box for easy carrying. Before beginning construction, carefully examine both schematic and pictorial diagrams. It's wise for beginners to work with the pictorial diagram while doing the actual construction, as it shows positions and identities of each part, wire and connection. Then, as construction progresses, they should check



Want to try a receiver with fixed crystal detectors?
Here is a selective circuit with few components

By MILO ADLER

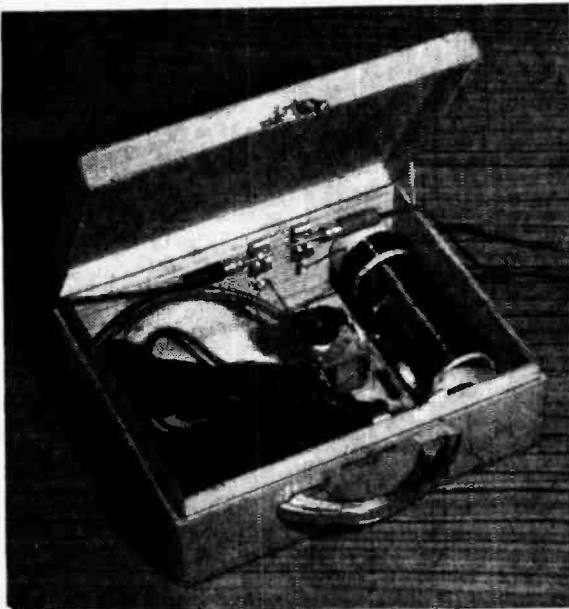

The crystal set is shown above mounted in the cigar box with headphones in place beside it.

with the schematic in order to become familiar with the symbols used and to better understand the actual workings of the circuit and its operating principles. When you can follow more complex circuits, and the symbols, part functions, and wiring procedure are completely familiar, you only need the schematic as a guide.

First drill two holes for mounting the coil $\frac{3}{8}$ in. from each end of the coil form and just large enough to pass the $\frac{5}{16}$ in. machine screws used for mounting the coil. Next drill two holes shown at A in the pictorial diagram in the coil form, locating the first hole $\frac{3}{8}$ in. from end of coil form as mentioned above and the second hole $\frac{1}{8}$ in. from the first one. Then carefully unwind 5 to 10 ft. of No. 22 enameled wire, being sure not to kink it as a kink may cause it to break while coil is being wound.

Pass about 5 in. of wire through the second of the two small holes in the coil form from the outside of the coil form towards the inside. Next pass the same wire through the first of the holes from the inside of the coil form, and pull small loop on inside of form taut. Fasten coil of wire

to a stationary object or have someone hold it, being careful not to cause any sharp bend in the wire. Pull the wire taut and slowly rotate the coil form, thus winding the wire on the form. Wind 20 turns on the form for the primary winding. Stop every few turns and press the turns of wire together so that coil form cannot be seen between turns of wire. After 20 turns are wound on the coil, leave approximately 5 in. of excess wire and cut off the remaining portion.

Drill three small holes at point B (see pictorial diagram) and fasten end of primary winding through two of these holes in the same manner as the beginning of the coil winding, using two of the holes. Use the center and remaining hole at B to fasten beginning of secondary winding. Start the secondary winding as you did the primary, with a 5 in. lead coming from the coil, and place 30 turns on the coil form. Place the tap (T in diagram), at 30 turns from point B on the coil; this tap or loop is made by scraping the black enamel coating from the wire, twisting to form a small loop, and soldering the wire together.

Now place the remaining 80 turns of the 110-turn secondary on the coil form and fasten end of winding through two small holes (at C in diagram). If you want to be able to adjust the sensitivity and selectivity of this crystal

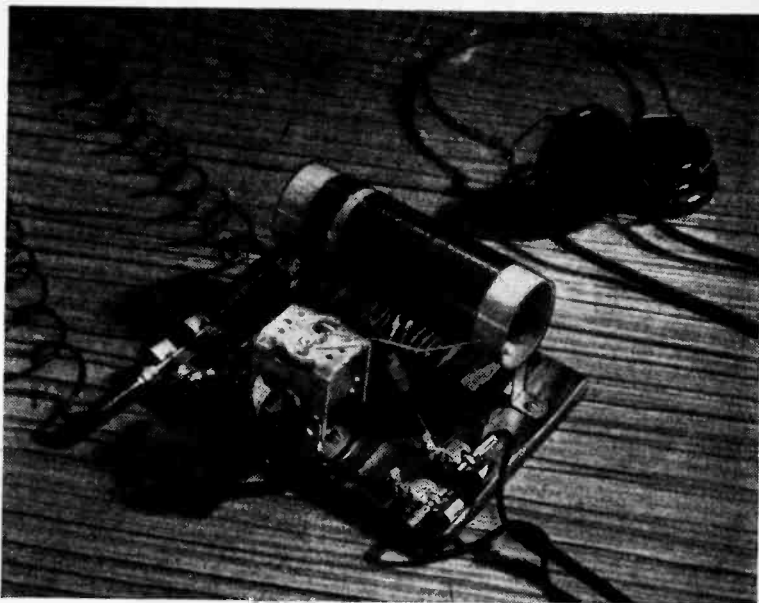

Completed "breadboard" version of crystal set with headphones connected.

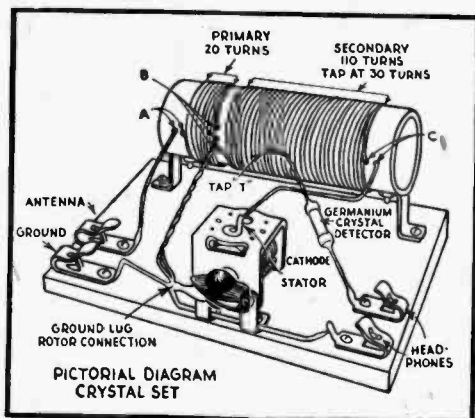

set, place taps every 10 to 15 turns while winding the secondary winding. But don't place any taps on the secondary before the first 30 turns.

Receiver construction will vary depending upon whether a "breadboard" or cigar-box model is to be constructed. The wiring of the receiver will be the same regardless of which model is constructed, so instructions for constructing the "breadboard" model will be

given first, followed by instructions for mounting parts in a cigar box.

For the "breadboard" model, first mount the coil mounting feet on the coil form, taking care not to damage the coil. Then mount coil as shown on the pictorial diagram. Next mount the variable (tuning) condenser with angle brackets; be sure to place a solder lug under condenser mounting screw, as shown in the pictorial diagram. Fasten clips to baseboard with wood or self-tapping metal screws.

If receiver is being constructed in a cigar box, after coil is completed cement coil in location shown in photo, using a quick drying radio or model builders' cement. Let cement dry thoroughly before doing any further work on the set. Then mount the variable condenser in the box with cement and two No. 6 by 1/4 in. wood or self-tapping sheet metal screws. Mount the

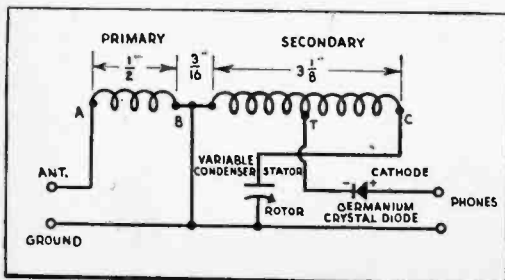

four clips for headphone, antenna and ground connections in the box with the same size screws that were used to mount the tuning condenser. Be sure to mount a soldering lug on the frame of the tuning condenser with a No. 6 by $\frac{1}{8}$ in. machine screw.

Solder all connections, using rosin core solder only (acid-core solder and acid flux may cause corrosion). Pre-heat parts for easier, better work by holding soldering iron tip against wire and terminal to be joined for a few seconds. Then apply just enough solder to cover connection and fill crevices between wires. Remove iron, but do not move wires until solder has set—this takes only a few seconds. When more than one wire is to be connected at a particular point, don't solder and resolder. Install all wires

MATERIALS LIST—CRYSTAL SET

Receiver Parts:

- 1 $1\frac{1}{2}$ " x 5" coil form
- 55 feet No. 22 enamel wire
- 1 381.4 mmfd. midget single gang condenser (Allied 81-009)
- 1 Germanium crystal diode (Sylvania type 1N34; Allied 7-219) or General Electric type 1N48 (Allied 7-250)
- 1 $1\frac{1}{4}$ " pointer knob)
- 4 Fahnestock clips
- 1 $4\frac{1}{2}$ " x 6" x $\frac{3}{8}$ " plywood base or wood cigar box, depending upon model being made
- 8 No. 6 x $\frac{1}{4}$ " wood screws
- 2 6-32 x $\frac{3}{16}$ " or longer machine screws
- 2 coil mounting brackets
- 2 condenser mounting brackets
- 1 solder lug

Accessories:

- 1 2000 ohm headset
 - 1 outdoor antenna
-
-

to that point before soldering. Work slowly, checking each connection as it is made. Mark the diagram with a colored pencil as each connection is completed. Be sure enamel coating on wire is scraped off before connecting ends of coil into set.

Cure for Weak Stations

To get the best results, use a good antenna, good ground, and a pair of high-resistance headphones (1000 ohms or higher). In most cases a long antenna is unnecessary. However, if stations are weak, or if nearest one is a great distance from you, you may need to secure an antenna at least 50 ft. long and as high as possible, and adjust set for maximum sensitivity by moving connection at point T over to point C (see diagram). Use glass or porcelain insulators at the antenna ends and rubber-covered wire for a lead-in to prevent contact with grounded objects.

If taps are made on secondary winding when coil is constructed, move connection to crystal diode up and down coil until a tap is found which gives the best performance for the station being received. For a ground, drive a few feet of metal rod or pipe into moist earth or make a connection to a cold water pipe or radiator.

The broadcasting station microphone converts sound to an audio frequency (AF) current which fluctuates as the sound changes in pitch and volume. This AF current is an electrical pattern of sounds picked up by the microphone. Since it cannot be transmitted alone it is combined with a strong, steady radio frequency (RF) current. The combination is sent out through an antenna, becoming radio waves. The RF signal is called the "carrier" because it "carries" the AF signal. Some of these waves will strike your receiver antenna, setting up a current which travels to the set. The crystal detector "demodulates" the signal—that is, it takes out the RF signal, but allows the AF to continue to the headphones where it is converted to sound. The coil and tuning condenser select a particular signal from the many constantly striking your antenna. Hence you adjust the condenser to "pick up" the station you want.

Kit Available

A complete kit for constructing the "breadboard" model of this receiver is available at a cost of less than \$4.00. This kit contains all materials necessary for constructing the "breadboard" model. The only extra components needed will be the cigar box when constructing this particular model. The cigar box used by the author was for Corina Larks cigars. It was sanded to remove the printing and then given two coats of shellac. The handle shown may be purchased from your local hardware store.

• If you want to secure the kit for constructing the "breadboard" model of this crystal set, write Allied Radio Corp., Dept. S, 833 W. Jackson Blvd., Chicago 7, Ill.

Vacuum Cups Give Radio a Soft Ride

• Radio amateurs and experimenters find that vacuum cups with a machine-screw molded in and a thumb-nut attached, make good rubber cushions and shock absorbers on a receiver or transmitter chassis. Sketch shows a gang-condenser held and cushioned on chassis, a sub-as-

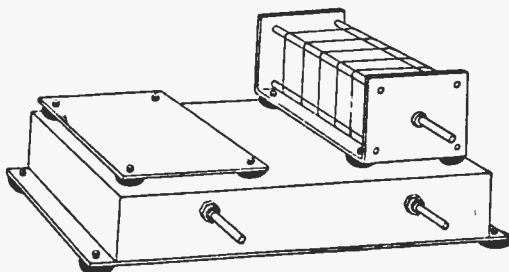

sembly panel cushioned and held to chassis, and chassis itself cushioned from operating table. In latter case, cups also keep chassis from sliding and scratching furniture. Cups are sold in most supply stores.—ARTHUR TRAUFFER.

Experimenting With Neon Glow Tubes

Tiny NE-2 glow tubes open up a new world of test and experiments, including photo-electric control, meterless volt-meter, multi-tester, electronic metronome

By T. A. BLANCHARD

NO bigger than a B-complex vitamin capsule, the tiny NE-2 glow lamp can be adapted to more than a score of unique electronic testing and experimental applications, including a continuity tester, oscillator, light beam control, and a stroboscope. Unlike a conventional radio tube with multiple elements, the glow lamp contains only two metal electrodes sealed in a glass, neon gas filled envelope. The glow tube requires no filament because the neon gas is ionized and conducts electricity when a certain voltage is applied across the leads. Either electrode will serve as the anode or cathode.

Since the NE-2 glow lamp does not contain a "starter" element, the flow of current from one electrode to the other is regulated by the input voltage. With the required 220,000-ohm series resistor, electron flow starts at about 60 volts. The glow tube makes an excellent oscillator and "trigger" tube but is not suitable as a radio frequency detector. The visible glow of current permits the NE-2 lamp to be used for a host of electrical and electronic continuity tests (Fig. 4). The glow tube is also sensitive to visible and infrared light rays.

It has often been said that the simplest inventions made the most money for the inventor—obviously because they performed more useful functions with the least effort in manufacture and/or application. The glow tube is one of these simple but versatile tools. Illustrated and described here are but a few of the many things you can do with these little glass capsules.

Pocket Pen Multi-Tester

To make this handy pocket tester in a dime store "ball point" pen, pull out and discard cartridge of barrel. With a sharp

Fig. 1. Code practice oscillator provides tones in a wide choice of frequencies. NE-2 tube also blinks as key is depressed.

Fig. 2. 4-in-1 control is adjusted to operate as "electric eye." Same device also functions as stroboscope, metronome, light ray detector.



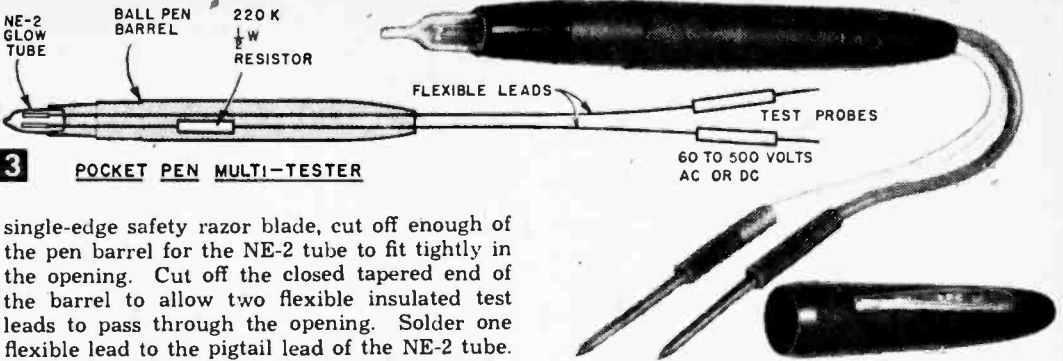

3 POCKET PEN MULTI-TESTER

single-edge safety razor blade, cut off enough of the pen barrel for the NE-2 tube to fit tightly in the opening. Cut off the closed tapered end of the barrel to allow two flexible insulated test leads to pass through the opening. Solder one flexible lead to the pigtail lead of the NE-2 tube. Insert a 220,000-ohm, 1/2-watt resistor in series with the remaining pigtail tube lead and test probe as shown in Fig. 3.

You can fit the flexible test leads with regular insulated radio phone tips or with home-made probes. To make tips cut the heads off a couple of finishing nails leaving 1/4 in. of the pointed portion. Butt-solder the nails to the end of test leads. Force a 7/8-in. length of plastic sip straw over the nail tips and insulated leads to form a protective sleeving. (Plastic sip straws are sold in all dime stores. One 5-cent straw and five cents worth of finishing nails, 1/4 lb., will make about \$5.00 worth of commercial phone tips.)

Fig. 4 shows only a few of the electronic tests you can perform with the pocket tester. You can also detect defects in fixture cords, blown fuses, polarity of power lines and opens or shorts in motors. Test in Fig. 4A applies to conventional radio frequency tests. Do not probe around the oscillator of a TV high-voltage supply which is similar to schematic shown.

Fig. 4B shows tester connected across output of radio receiver through a .05 mfd. capacitor.

The pocket multi-tester was built into a discarded pen barrel for easy handling.

The glow tube will "flutter" at various intensities as speech and music is reproduced by speaker. Fig. 4C shows how to test for a voltage breakdown in radio circuits. Check each stage of the receiver in turn. For example, if the lamp fails to glow when connected across cathode and plate, and cathode and screen-grid of tube socket, positive B voltage is lacking. Look for defective rectifier, resistor or electrolytic capacitor. Only one electrode should glow on this test. If both electrodes glow, it indicates a-c in a circuit where only d-c should exist.

Code Sending Oscillator

Both the oscillator and the 4-in-1 control require a simple d-c power supply. Fig. 5 shows a suitable power supply assembled on a small wood base consisting of a small selenium rectifier (rated 40 ma. or more), a 150-ohm, 1-watt resistor, and a 16 mfd., 150-volt electrolytic capacitor. Because any variation in the values of the resistor and size of the electrolytic capacitor will alter the output voltage of the d-c power supply, make no substitutions. Use only values shown in Fig. 5A.

You can produce all the actual CW transmission tones heard on shortwave ham and commercial frequencies. In the code oscillator (Fig. 1), varying the 1-megohm potentiometer changes the tone frequency. If you want to amplify the oscillator signal, connect a 3:1 interstage primary of a transformer to the phone jacks and the secondary to the amplifier input.

This oscillator makes an all-electronic warning siren when connected to a public address system. Simply set the

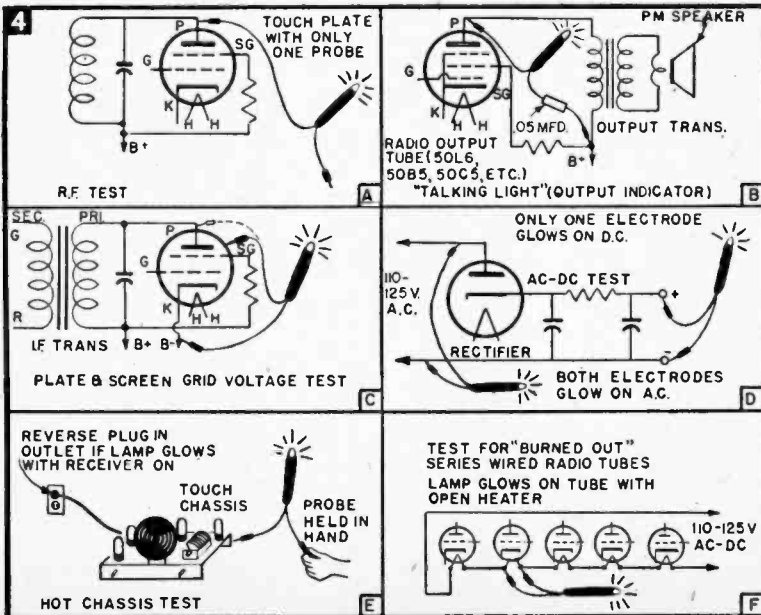

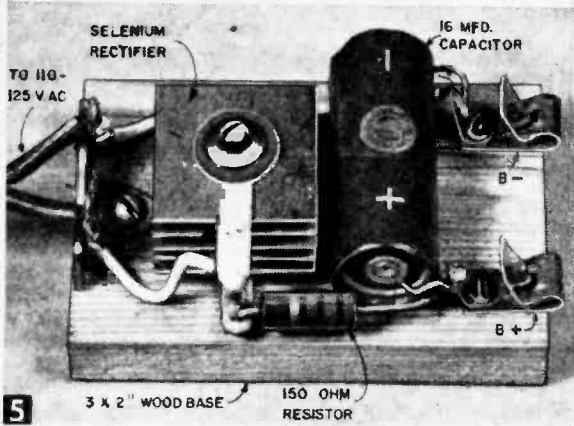

5

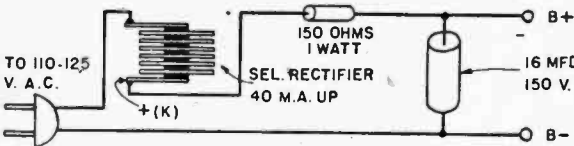

A POWER SUPPLY FOR OSCILLATOR & 4-IN-1 CONTROL

This simple selenium rectifier converts a-c to d-c for operating the 4-in-1 control and code practice oscillator.

tone control to a suitable pitch, then disconnect the a-c line plug of the power supply. The charge in the electrolytic capacitor remains for several minutes, gradually tapering off and reducing the voltage to oscillator. As the voltage drops, it gradually lowers the pitch of the oscillator's tone. The sound resembles a mechanical velocity siren. As the tone signal's frequency drops, plugging in the a-c line will again set the siren wailing.

For two-way code practice set connect two pairs of headphones in series and two practice keys in series. If you are on the receiving end, hold your key down while your partner transmits. It is also possible to provide a continuous B-circuit and insert key(s) in series with phone(s). However, there is a tendency of the oscillator to break down and/or "motorboat" with the latter hook-up. Do not touch any wiring or phone terminals while line cord is plugged in.

4-in-1 Control

With this single unit (Fig. 4) you can accomplish feats impossible with any single piece of conventional vacuum tube electronic apparatus. Simply by varying the position of the 1-megohm potentiometer, this novel control functions as photo-electric alarm, stroboscope, metronome (electronic timer), and capacity alarm. In addition the control reacts to invisible infrared frequencies of light.

Metronome. As the potentiometer is turned from minimum to maximum, you can hear clicks in the headphones which may be varied from one click every few seconds to about 300/second. The setting of the potentiometer determines how rapidly the .05 mfd. capacitor is fully charged. When the capacitor is charged up it discharges through the NE-2 tube producing a click in the phone. Instantly the capacitor starts another cycle followed by another click. The speed control is merely a variable resistance which controls the length of time required to charge the capacitor.

Electronic Stroboscope. You will have noticed that as the beats of the metronome were speeded up, the NE-2 lamp flashed with increasing rapidity. The illumination provided by the neon tube may be used in a darkened room to view electric fans, motors or rotating machinery. Viewed in the rapid glow of the NE-2 lamp, the fan blades will appear to stand still. Adjust the speed control (1-megohm pot.) until the flashes synchronize with the speed of the fan or other rotating device. If the lamp does not flash fast enough, change the 3.3-megohm resistor to a 1.5- or 1.8-megohm value.

Since the illumination from the NE-2 lamp is limited, you'll see more from the strobe light by using a flashlight reflector. The headphones must remain connected in the circuit even though not used.

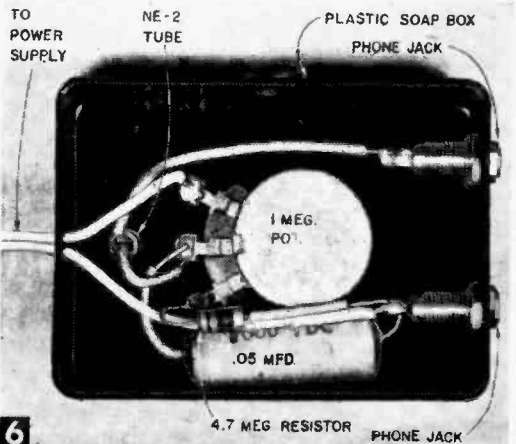

6

Bottom view of 4-in-1 control assembled in base of plastic soap container.

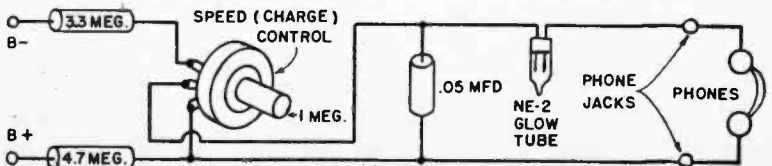

A 4 IN 1 PHOTO-ELECTRIC, CAPACITY, METRONOME, CONTROL

Photo Control. This control is identical to the metronome, and exposing the NE-2 tube to light causes it to fire on a lesser voltage than in the dark. Cover the neon lamp with a black paper cylinder or small cardboard box. Do not use a metallic object. Turn the speed control until the phone clicks cease. This setting is critical. Now quickly remove the paper tube, and a distinct click will be heard in phones each time tube is exposed to light. You can achieve the same effect by flashing a beam in a darkened room.

As a photo control the NE-2 is so sensitive that it responds to very low day-light levels—far lower than most conventional commercial electronic light controls. The success of this “electric eye” is dependent upon the potentiometer setting and adequately shielding the NE-2 tube from stray light.

Capacity-Infra Red Alarm. Adjust the potentiometer until the NE-2 tube ceases to fire. It is not important whether adjustment is made with the tube in a fully illuminated room or shielded against light, but it must be one or the other. Any object brought close to the NE-2 lamp will cause a single click in the headphones. The click from a plastic rod or other non-metallic object passed close to the NE-2 tube is due to infra-red radiation. Metallic objects, human hand or grounded objects also produce a click, but these

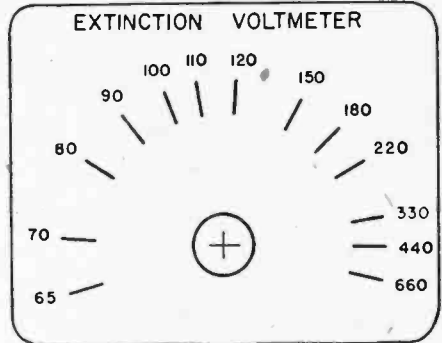
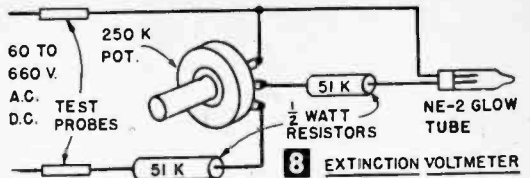

A FULL SIZE PATTERN OF DIAL

clicks are not due solely to infra-red radiations but partially to capacity influence.

Lest you immediately visualize this device as an ultra-simple uranium detector we have sad news: The NE-2 is sensitive to too many rays to be selective. Yes, the detector will click on uranium bearing ore, but it will also click on any other type of ore.

Extinction Voltmeter

This is an elaborate version of the pen multi-tester (Fig. 8). A 250,000-ohm potentiometer used as a variable voltage divider and calibrated against known voltages makes the NE-2 tube a reliable meterless instrument. The voltmeter shown in Fig. 8 performs all the functions of the pen tester, but makes possible the actual indication of any voltage from 60 to 660 volts a-c or d-c.

You can build the extinction voltmeter into a small plastic box. Once assembled, the extinction voltmeter must be calibrated against known voltages. The best way to calibrate the voltmeter is to take it to the manual training departments of your local high or vocational schools and compare it with variable transformers known as variacs or transtats. Simply turning the knob on the transformer provides any desired voltage.

Attach the probes of the extinction voltmeter to the output terminals of the transformer. Set the knob to 60 volts. Now turn the potentiometer knob so the NE-2 tube just ceases to glow.

This will be the permanent 60 volt setting. Repeat the operation with variable transformer set at other standard voltages: 70, 80, 90, 100, 110, 120, up to 660 or 700 volts. Remember that the correct voltage indi-

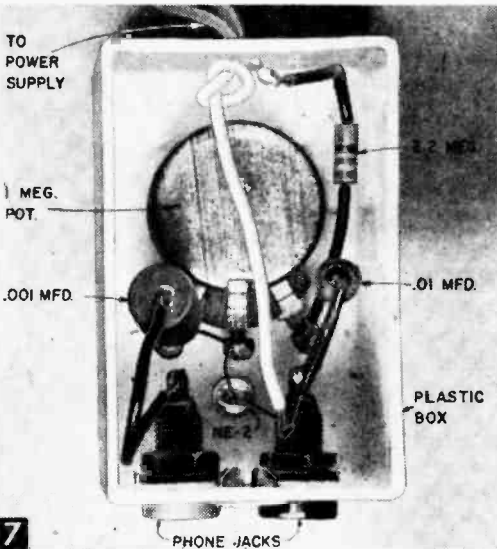

7 Bottom view of code practice oscillator built into a small plastic box originally made to store razor blades.

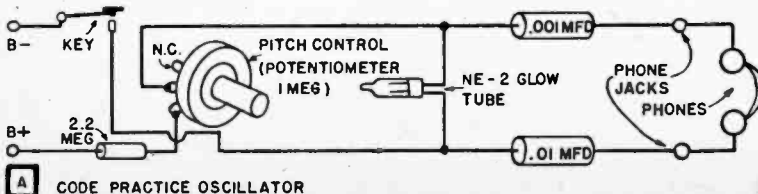

A CODE PRACTICE OSCILLATOR

OHMITE® OHM'S LAW CALCULATOR

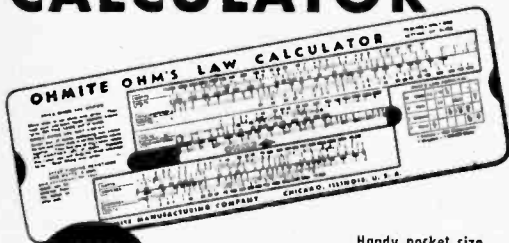

ONLY
25¢

Handy pocket size
Computes parallel resistance
Also includes standard slide rule

Figures Ohms, Watts, Amperes, Volts... Quickly!

Here's a simple and handy method of solving resistance problems. Ohmite's famous pocket size (9" x 3") calculator solves any Ohm's Law problem with one setting of the slide. In cardboard, 25¢; vinylite plastic, \$1.50.

OHMITE MFG. CO., 4973 Flournoy Street, Chicago 44, Illinois

Be Right with OHMITE

RHEOSTATS • RESISTORS • TAP SWITCHES

MAKE GOOD MONEY in

Television Servicing

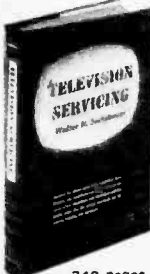

TV is expanding—and it pays big!

Get this brand-new, complete handbook for sure-fire working knowledge of TV installation, maintenance and troubleshooting. Tells you step-by-step procedures for audio IF alignment, video IF alignment, aligning RF amplifiers, mixers, oscillators, etc. All possible defects classified for ready reference, thoroughly analyzed to show what is wrong and why... and what to do to correct the defect. No mathematical knowledge needed! Practical, authoritative, up-to-the-minute, the perfect handbook for set owners, trainees, and repairmen.



Symptoms of defective operation easily recognized, quickly corrected by illustrations, diagrams and how-to-do-it facts in this new book.

USE IT 10 DAYS FREE

Coupon below brings you "Television Servicing" on FREE trial for 10 days, without obligation. Mail it NOW.

PRENTICE-HALL, Inc., Dept. M-RX-52
70 Fifth Avenue, New York 11, N. Y.

Send me, for 10 DAYS' FREE TRIAL, "Television Servicing." I will return it in ten days and pay nothing—or keep it and send \$1.35 down (plus postage) and \$2 monthly for 2 months.

NAME.....

ADDRESS.....

CITY..... STATE.....

SAVE! Send \$1.35 with this coupon, and we'll pay postage and packing.

ation on your neon voltmeter is the point where the lamp blinks out. You may use the facsimile dial plate (Fig. 8A), but it should still be calibrated for accuracy because of the variations in the resistance taper of various potentiometers.

To use the dial plate (Fig. 8A), determine from your local power company the exact line voltage. Insert probes in the a-c outlet and turn potentiometer until NE-2 tube blinks out at this voltage. Attach the pointer knob in line voltage on the accompanying dial plate, being careful not to move shaft adjustment. Tighten set-screw and the remaining settings will fall approximately in line.

The above calibrations are for alternating current. For d-c, the actual voltage will be about 15% higher than the knob setting shows. For example, if the dial indicator points to 90 volts on a d-c test, multiply 90 by 1.15 which will give you the true d-c potential—103.5 volts. You can distinguish d-c from a-c by the fact that only one the NE-2 electrodes glows. On alternating current, both elements will glow.

These suggested uses for the versatile NE-2 glow tubes are only a few of the many possibilities and you can find dozens of other uses by experimenting.

Secret Switch for Table Radio

• If you have a table radio you don't want everybody to use, mount a small mercury switch on the radio chassis with a cable clamp, and

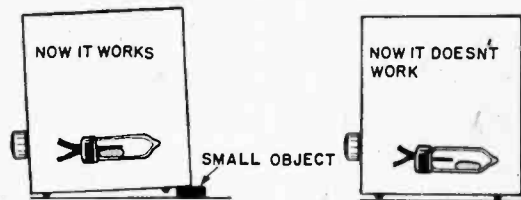
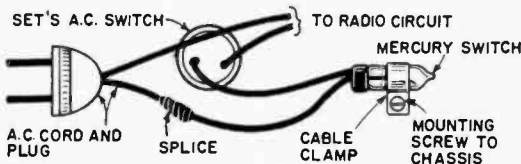

connect the mercury switch leads in series with the regular a-c switch. When the radio stands level, the mercury switch should pass no current, but when the radio is tilted forward slightly by placing a small object underneath the rear of the cabinet the mercury switch turns the set ON.—ARTHUR TRAUFFER.

Protecting Screw Threads

• To prevent the nuts from rusting tight on bolts, dip the threaded end of the bolt in shellac before turning the nut on. The nut can then be removed later without any trouble.—TED OTSU.

Short-Wave Converter

Your regular radio becomes a high-powered short-wave set with this simple frequency-changing device attached to its antenna post!

By THOMAS A. BLANCHARD

YOU can listen to broadcasts (nearly all in English) from Argentina to Zanzibar with this simple short-wave converter, connected to any superheterodyne type radio. In an 8-hour period this converter brought in interesting news and educational broadcasts from Australia, Argentina, French Africa, Belgian Congo, England, Denmark, Russia, Spain, Switzerland, Turkey, plus distant U. S., Canadian and Central-American stations. The converter was attached to a 5-tube table set using a 1-lamp fluorescent fixture as a makeshift antenna.

A converter picks up the feeble short-wave signal by a tuned R. F. amplifier and tuned local oscillator-mixer and converts the signal from short- to medium-wave frequency. The standard broadcast set becomes an intermediate frequency (I.F.) amplifier for the converter. Thus a 2-tube converter used with a 5-tube radio often is equivalent to a specially designed 7-tube short-wave set.

The converter shown in Fig. 2 was assembled on a salvaged chassis because it matched a plastic

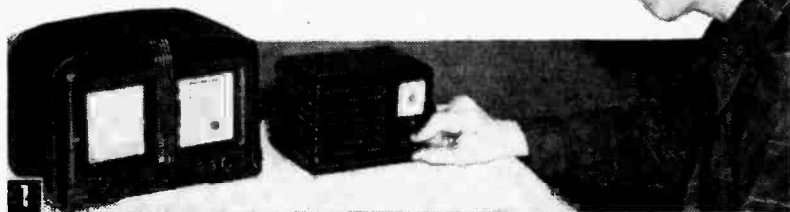

Converter attached to antenna of any standard superheterodyne radio adds world-wide short-wave reception.

cabinet on hand. Fig. 3 indicates a template which will fit most stock cabinets available from radio supply houses. Its width and depth can be varied to meet your own requirements. The chassis is the only special part required as all other items are stock radio materials.

You may wind the short-wave antenna and oscillator coils but their cost is so small that commercially made coils are advised. The antenna coil is wound on a $\frac{3}{8}$ -in. dia. tube with 12 turns of #20 solid plastic covered hook-up wire for the secondary. The primary winding is $2\frac{1}{2}$ turns of #30 enameled wire interwound among the last 3 turns of the secondary. The Hartley oscillator coil is a shielded type with an iron core slug to permit its matching to various 2-gang variable capacitors. This coil consists of 12 turns of #24 enameled wire with turns spaced $\frac{1}{4}$ -in. apart on a coil form measuring $\frac{7}{16}$ -in. dia. Bring out the tap at the 9th turn.

When using a standard broadcast band 2-gang superhet tuning condenser with a 420 mmf. R.F. section and 162 mmf. oscillator section, the oscillator coil slug screw projects $\frac{1}{4}$ -in. from the threaded bushing, and is locked in place with a 6-32 nut.

Check the Materials List, and order the components necessary before laying out the chassis. When parts are on hand, drill the small mounting holes because components do not always follow the same mounting dimensions even though their electronic characteristics are alike.

The filaments (heaters) of the R.F. amplifier tube (6AU6 or 6BA6) and the mixer (6BE6) operate from a small 6.3 v. filament transformer

Converter components arranged on a salvaged aluminum chassis for easy wiring. Mark SW stations on blank dial as they are located. Pointer indicates 31-meter band position.

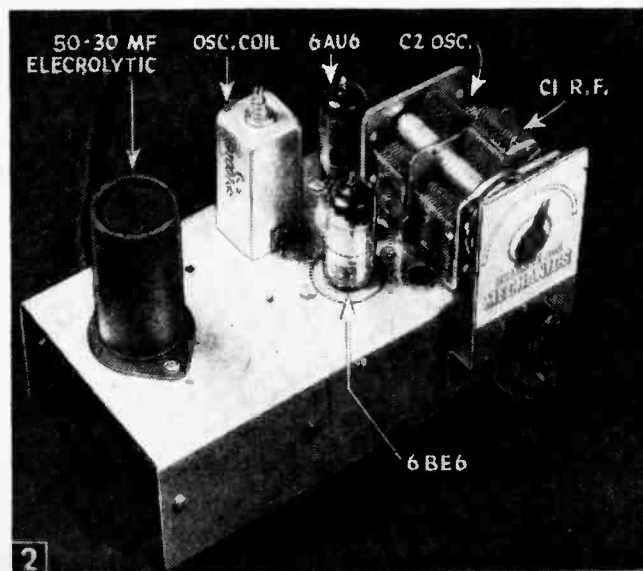

rated 1 or 1½ amps. Rectification for dc plate voltage is provided by a selenium disc rectifier of 100 ma. size with a 50-30 mfd. electrolytic capacitor rated at 150 working volts for dc filtering.

The circuit employs an isolated hook-up to minimize danger from shock. An external ground is automatically provided through the power line. However, to keep background noise at a minimum, and also increase converter's sensitivity, ground the converter chassis to the receiver chassis or external ground (but not both). Should ac hum be present on higher frequencies, merely reverse plug of converter and/or set in electrical outlet.

Wire components with leads as short and direct as possible. "Pigtail" leads on condensers and resistors are usually long enough for wiring and save on hook-up wire. All resistors in the B+ circuit attach to a 1-lug soldering terminal. A similar 1-lug insulated strip is used for all isolated ground (B-) connections. Locate the line switch at a convenient spot.

Because tuning of short-wave stations is very critical, the circuit includes an auxiliary fine

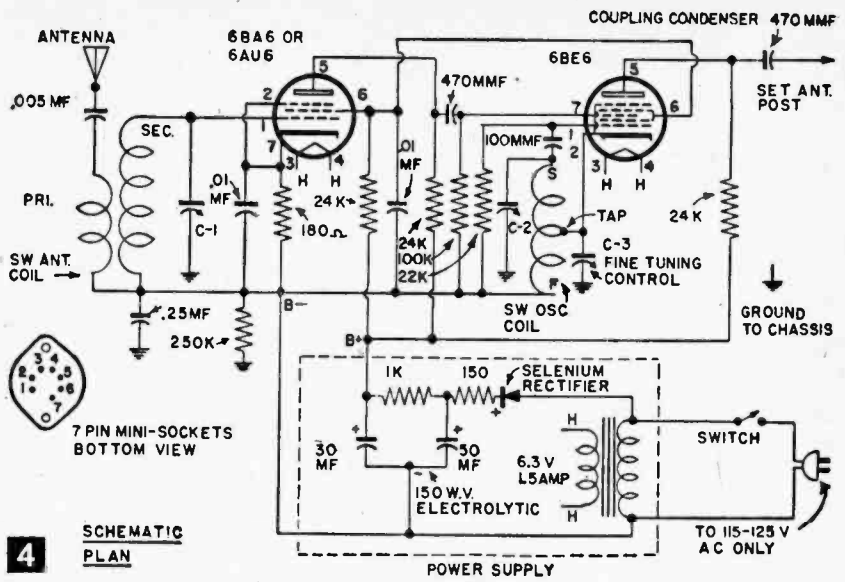

4 SCHEMATIC PLAN

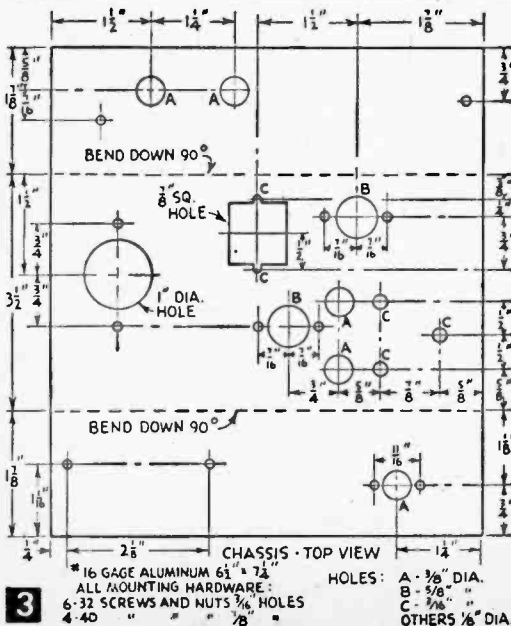

3 CHASSIS - TOP VIEW

- MATERIALS LIST—SHORT-WAVE CONVERTER**
- 1 P.c. #16 aluminum, 6½ by 7¼, for chassis
 - 1 P.c. #16 aluminum, 1¾ by 4¾, for dial plate
- Capacitors**
- 1 2-gang variable (420 mmf. R.F. section, and 162 mmf. Osc. section) with drum shaft for dial drive. C-1 (in schematic) is 420 mmf. and C-2 is 162 mmf.
 - 1 Midget air trimmer, approx. 35 mmf. max. capacity (C-3)
 - 1 Electrolytic can type, insulated capacitor, 50 & 30 mf., 150v.
 - 1 .25 mf. molded paper capacitor, 150 w.v. or higher
 - 2 .01 mf. molded paper capacitor, 150 w.v. or higher
 - 1 .005 mf. molded paper capacitor, 150 w.v. or higher
 - 2 470 mmf. molded mica or ceramic capacitors
 - 1 100 mmf. molded mica or ceramic capacitors
- Resistors**
- 1 150 ohm carbon resistor, 1 watt
 - 1 1K (1000) ohm carbon resistor, 1 watt
 - 1 180 ohm carbon resistor, ½ watt
 - 1 22K (22,000) ohm carbon resistor, ½ watt
 - 3 24K (24,000) ohm carbon resistor, ½ watt
 - 1 100K (100,000) ohm carbon resistor, ½ watt
 - 1 250K (250,000) ohm carbon resistor ½ watt
- Coils**
- 1 Short-wave antenna coil. (Stanwyck #402; 5.5 to 18 mc.)
 - 1 Short-wave oscillator coil. (Stanwyck #231-1; 5.5 to 18 mc.)
- Misc. Components**
- 2 7-pin miniature tube sockets
 - 1 100 ma. selenium rectifier
 - 1 6AU6 and 6BE6 tubes
 - 1 6.3v., 1 or 1½ amp. filament transformer
 - 1 2-screw terminal strip
 - 2 1-lug soldering strips
 - 1 dial drive bushing, pointer
 - 1 Line switch and cord
 - misc. hardware and knobs.

tuning control. Where one station is received at a given spot on the dial of a regular broadcast set, there may be 5 or 6 short-wave stations in the same tuning area on the converter dial. A midget air trimmer of about 35 mmf. maximum capacity connected across the tap and negative return of oscillator coil provides this fine tuning control.

The plates of the fine tuner are normally kept in the unmeshed (open) position. With the main tuning knob of the converter, tune slowly until picking up a station. Now use the fine tuning control to spread out the stations on a particular band. When a specific short-wave band is lo-

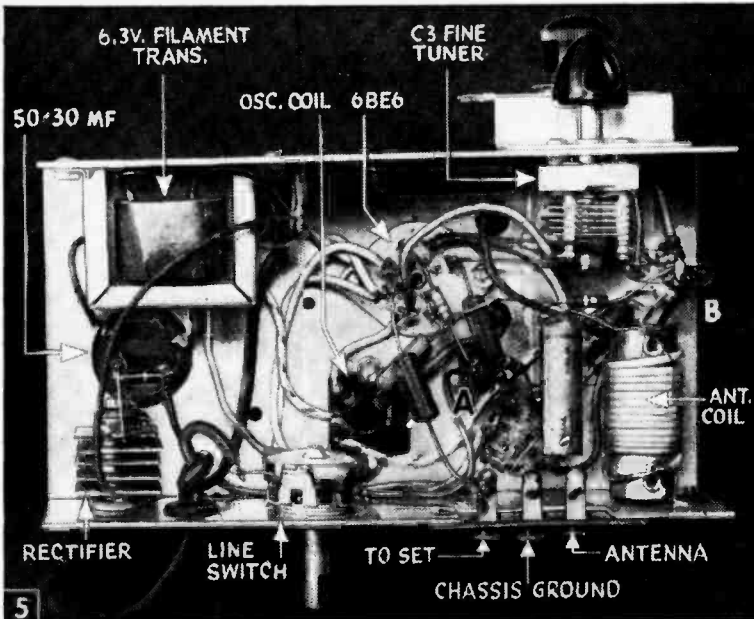

Bottom view of converter showing components mounted on underside of chassis.

cated (19, 25, 31 or 49 meters) mark the location in pencil on the hand-made converter dial.

The midget variable condenser spreads individual stations. Turning the dial of the broadcast set left or right "peaks" the I.F. for each station received. Set the dial of the regular broadcast receiver to some suitable intermediate frequency between 800kc. and 1000kc. The broadcast band radio dial doesn't tune in the short-wave station, and you only turn its dial for extra sharp tuning. When changing stations, always return the radio dial to its original setting at a spot where no regular station comes in. Use the volume and one control (if any) on the usual broadcast set.

If the short-wave converter is used with a small table radio with a built-in loop antenna, it isn't necessary to disconnect the converter output lead to the radio antenna; when converter is shut off, radio performs normally. In cases where converter is used with a radio that requires an outside antenna, connect a small shorting switch across the converter input to cut out the converter when receiving on the regular broadcast band. If your table superheterodyne receiver has no antenna connection, connect the converter to the end of the loop wire soldered to the stationary plates of the R.F. tuning section of gang capacitor (large plates), and change the 470 mmf. coupling capacitor in the converter to a 20 or 50

mmf. size, or a mica adjustable trimmer capacitor may be used.

A cord dial drive provides vernier tuning adjustment although a 2-gang superhet tuning capacitor can be coupled to the 1/4-in. shaft for direct knob tuning. The drum tuner for a cord drive requires a dial pointer, length of linen dial cord, and a drive shaft assembly—all very inexpensive. Thread the dial cord as in Fig. 7. First close the capacitor plates, and tie one end of the cord to the tension spring. Before tying the final knot at the tension spring, be sure all slack is out of cord. If cord stretches, move the tension spring to an adjacent hole in drum. Make

up a dial plate as shown in Figs. 2 & 6.

An outdoor antenna for short-wave reception need not be more than 50 ft. long or you can pick up signals with a short indoor lead, metal curtain rod or other non-grounded metallic object. If trimmer screws on 2-gang tuning capacitor are tight at time of purchase, loosen them by screwing out half a turn and leave them that way.

Reception on various short-wave bands varies from day to day. At times reception below 20 meters may be impossible, while other bands are okay and vice versa. Reception in the 31 meter band is fairly consistent, but reception of various stations in this band may vary. Skip effect sometimes causes a high-powered U.S. short-wave station located within 100 miles to come in poorly,

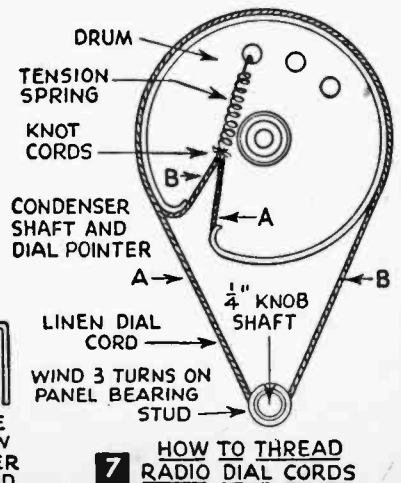
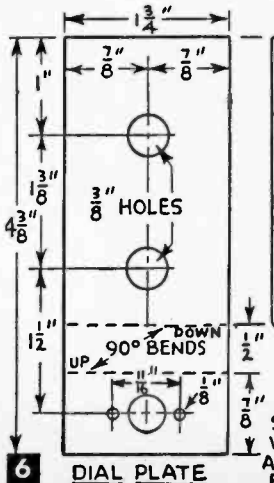

while Australian broadcasts blast you from the room. For example, UN and Armed Forces radio broadcasts originating in San Francisco and Los Angeles come in strong on the eastern seaboard.

For a complete listing of all U.S. and world short-wave stations see "White's Radio Log" at large newsstands, or direct from publishers for 25c. C. DeWitt White Co., P. O. Box 142, Bronxville 8, N. Y.

THIS sensitive FM Tuner regularly receives stations 90 airline miles distant, and can easily be connected to the audio system of nearly all AM radios. Miniature tubes, a selenium rectifier, slide-rule tuning dial, and a handsome cabinet are outstanding features of this tuner. Brand names and model numbers used on original unit are shown in materials list where certain parts must meet space requirements on the chassis. It's a good idea to compare the materials list and circuit diagram with photos to determine placement and purpose of each piece before building.

Start construction by laying out on paper a full-size chassis drawing. Fasten this template to the metal chassis with Scotch tape and use it as a guide when drilling all holes. Mark hole centers lightly with a center punch and then drill holes according to sizes shown on the chassis drawing. No holes are shown for mounting screws on tube sockets and IF transformers because these vary slightly with different shipments of the same brand. Drill mounting holes to fit the components you

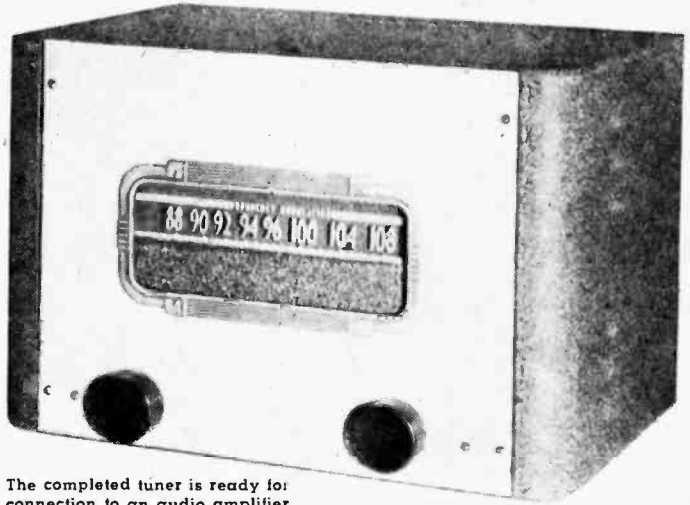

The completed tuner is ready for connection to an audio amplifier or phono jack on console radio.

FM TUNER with Sensitivity

This sensitive 7-tube tuner receives stations
90 airline miles distant

By ROBERT H. HAWKINS

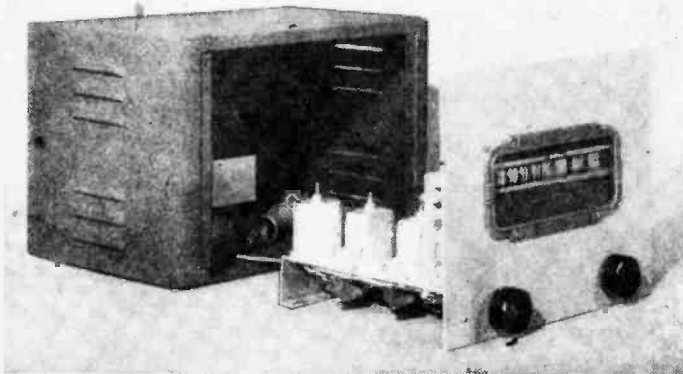

Chassis is removed from cabinet to show means of mounting front panel and hole in back of cabinet through which power cord and antenna connections pass.

purchase. These holes are usually drilled with a #28 drill, which takes a 6-32 machine screw. After drilling all holes and making two cut-outs

on the chassis (with a scroll saw and metal-cutting blades), remove any burrs around holes with a file. Next lay out 8 x 10 in. front panel (see drawing), marking hole centers as before. File off any rough edges.

To mount parts on chassis, first make two dial plate brackets to support slide-rule dial and two condenser mountings for the 3-gang tuning condenser. Then mount filament transformer, filter choke, electrolytic capacitor, tuning condenser, selenium rectifier, tube sockets, IF transformers, discriminator transformer, anten-

na binding post, volume control and switch, and finally, slide-rule dial, in that order. With parts mounted, check photos again for correct place-

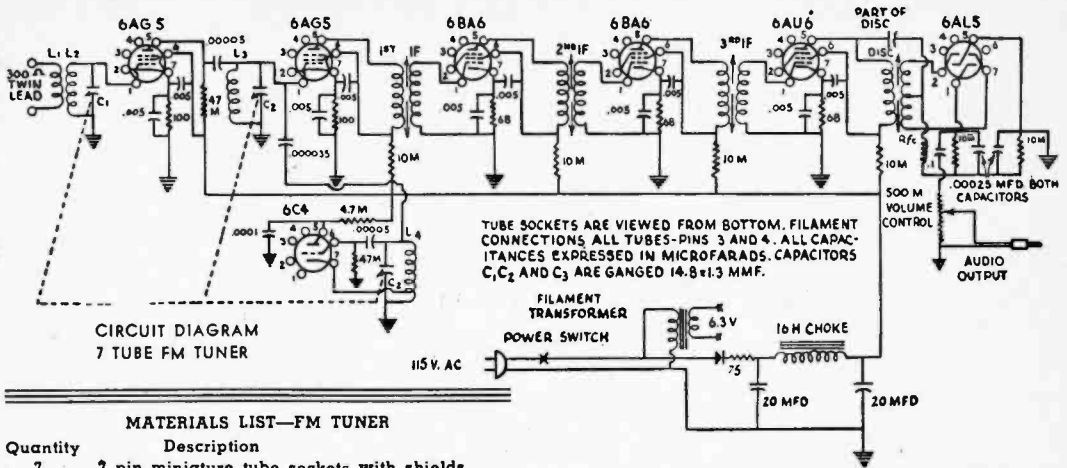

CIRCUIT DIAGRAM
7 TUBE FM TUNER

MATERIALS LIST—FM TUNER

Quantity	Description
7	7 pin miniature tube sockets with shields
1	Croname tuner assembly, Type 233
1	Alternate scale for above tuner, 88-108 megacycles
1	7 3/8" x 9" x 1 1/2" chassis
1	Selenium rectifier, 100 milliamper rating
1	6.3v filament transformer, Thordarson T-21F10
1	16 henry, 50 milliamper filter choke, Stancor C1003
1	3 gang FM tuning capacitor, 15 mmf./sec.
1	20-20 mfd electrolytic capacitor, 150 WVDC
1	0.1 mfd paper capacitor, 400 WVDC
13	0.005 mfd mica capacitor, 300 WVDC
2	250 mmfd mica capacitor, 300 WVDC
1	100 mmfd mica capacitor, 300 WVDC
1	50 mmfd mica capacitor, 300 WVDC
1	35 mmfd mica capacitor, 300 WVDC
1	500,000 ohm volume control with switch
2	47,000 ohm resistor, 1/2 watt
4	10,000 ohm resistors 1/2 watt
1	4700 ohm resistor, 1/2 watt
2	100 ohm resistors, 1/2 watt
3	68 ohm resistors, 1/2 watt
3	10.7 mc. IF trans., Meissner type 16-6665
1	10.7 mc. Discriminator trans., Meissner type 17-3484
1	2 1/2 millihenry RF choke
1	ICA steel cabinet, Type 3925 8" x 12" x 8", with 8" x 10" panel, Allied Radio #86-310
2	Round plastic knobs
1	3 foot length shielded wire
1	6" length Twin Lead antenna wire
1	10' length #20 solid hook up wire
1	Belden replacement lamp cord
1	Standard phone plug
2	6AG5 miniature tubes
2	6BA6 miniature tubes
1	6C4 miniature tube
1	6A46 miniature tube
1	6AL5 miniature tube
2	6-8v dial bulbs (#40 Min. screw base)

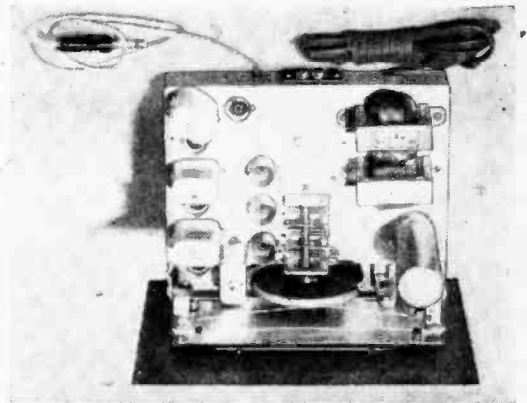

Top view shows placement of component parts. Tubes and shields have been removed to permit view of mounting details of sockets and tuning condenser.

ment and study proposed system of wiring. Proper placing of tube socket pins can make wiring more convenient and the leads short. Note that a tube socket pin arrangement has a front and back; try to duplicate positions shown in drawing of bottom view of chassis. Approximate location of either pin 6 or pin 1 can be determined from this drawing. Mount IF and discriminator transformers with terminals marked PLATE—B plus, toward front of chassis.

When starting to wire tuner, first make a B plus cable (see drawing). Then with short, neat connections wire the power supply (excluding

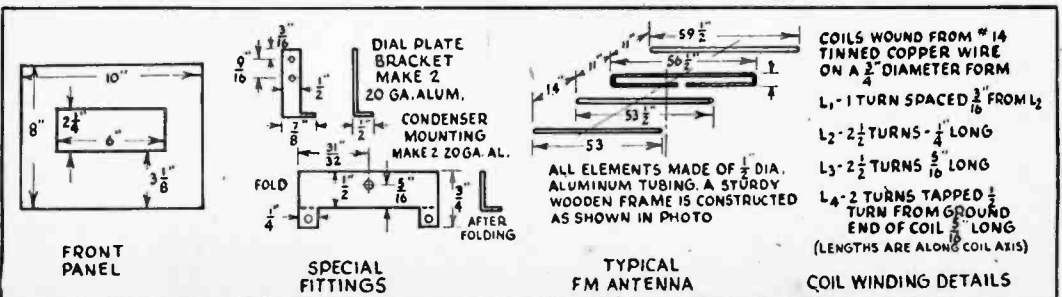

COILS WOUND FROM #14 TINNED COPPER WIRE ON A 2" DIAMETER FORM
 L₁-1 TURN SPACED 3/16" FROM L₂
 L₂-2 1/2 TURNS - 1/4" LONG
 L₃-2 1/2 TURNS 5/16" LONG
 L₄-2 TURNS TAPPED 1/2 TURN FROM GROUND END OF COIL 5/16" LONG (LENGTHS ARE ALONG COIL AXIS)

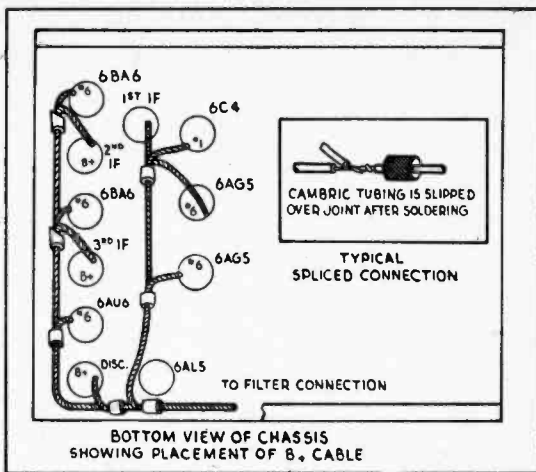
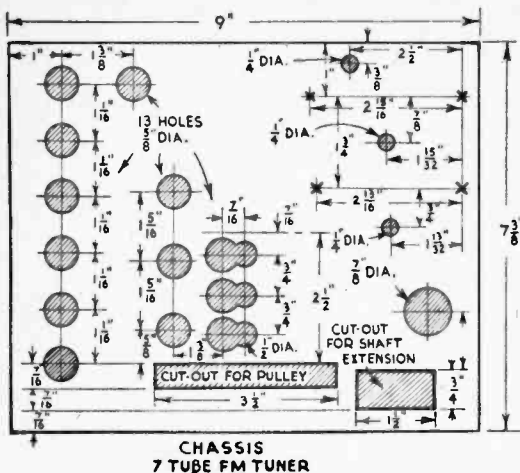

line cord), filament leads, B plus cable, ground connection bus (tinned #14 copper wire), RF coils (as shown in photo), and then the various resistors and capacitors, in that order. Make RF coils as shown in coil winding drawing; you may find that a very slight stretching or squeezing of the coils is necessary to obtain good alignment and tracking.

After wiring is complete and *carefully checked*, mount line cord. If line cord is wired last, it will not dangle in front of some connection to be soldered. Note that one side of line is grounded to chassis as is common on the ac-dc sets of today. This unit will *not* operate on dc. Remember, *don't put a ground connection of any kind on the tuner*. A two-terminal antenna binding post is used and *both* of them are connected to the 300 ohm twin-lead coming from the antenna. This unit can, however, be connected by the audio plug to any set having a ground connection because the shielded lead is connected to the chassis through a 0.003 mfd. capacitor. Using this type of circuit involves a danger of shock,

Bottom view showing wiring of power supply, position of RF coils and Twin-Lead connection from antenna binding post.

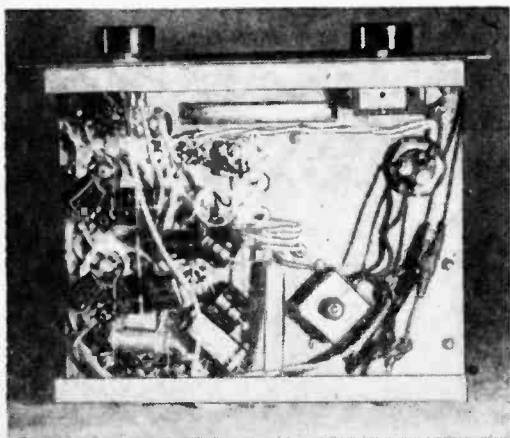

which can be avoided if you do not set tuner on a metal table or against water pipes, and use a crackle finish on cabinet, which acts as a good insulator. A metal cabinet shields tuner from any hum that might be picked up.

The original unit was aligned using a frequency-modulated signal generator and a cathode ray oscilloscope. You probably will not have these available, but almost all reputable radio service shops are equipped to complete the alignment for you. Of course, a nominal charge is made

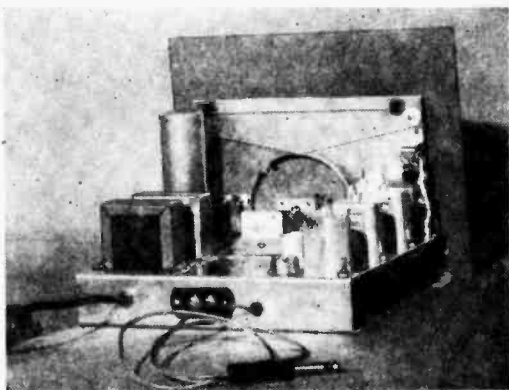

Rear view showing relative positions of power cord, antenna binding post and audio output line. Note wires connecting dial lamp on right edge of panel.

for this service with prices varying in different localities. A good job of alignment and tracking will make this tuner a unit of which the constructor can well be proud.

The type antenna suggested for the tuner is highly directional and capable of receiving weak signals (see drawings). Any commercial FM antenna will produce good results with this tuner when properly oriented and connected with twin-lead lead-in wire. When entirely finished, connect this unit to a good audio amplifier or the *phono* connection on most console radios and you can enjoy fine FM reception.

Wireless Broadcaster

Build this ultra-efficient phono oscillator
and do your own broadcasting

By MILO ADLER



Fig. 1. Wireless broadcaster connected to mike. Radio in background will receive broadcasts from this phono oscillator from as far away as 50 ft.

HERE'S a phono oscillator, capable of 100% modulation, which may be used with any phonograph pickup. Or, with a crystal mike, you can use this unit to broadcast through your receiver from as far away as 50 ft., without having any direct connection to the receiver. Either the standard crystal cartridge or one of the new magnetic cartridges may be used with this broadcaster. A phono-oscillator of this type is really a "miniature broadcasting station" which may be operated only because it has relatively low power and limited range. But it's a lot of fun if you want to do some home broadcasting.

The 12AX7 tube is used as an equalized preamplifier with the new magnetic cartridges or as a straight preamplifier with a crystal mike. One section of this tube is used as a single triode amplifier when a crystal pickup is used. The 50B5 oscillator is a novel design with the screen grid being used to modulate the modified electron coupled oscillator.

The chassis is formed from steel or aluminum (Fig. 5). Mount components (Fig. 3) so all leads will be short and

direct, and the entire unit will be compact. Mount tube sockets from under side of chassis (see diagram), to assure short leads. Support resistors and condensers by their own pigtail leads. Use 2 fiber washers to insulate jacks from chassis. Mount slide switch so it will operate freely when mounting bolts have been tightened. Mount the 5-terminal mounting strip and filter condenser next.

Attach Meissner type 14-1040 oscillator coil with nut furnished. Set iron core adjustment screw so top of screw is from $\frac{3}{8}$ to $\frac{1}{2}$ in. above chassis. Don't damage fine wires on oscillator coil during assembly and wiring. Study pictorial diagrams carefully before wiring. Solder all connections with rosin core solder. Don't use acid core solder or acid flux because it tends to corrode. Mark diagram with a colored pencil as each connection is completed. When more than one wire is to be con-

PARTS LIST—WIRELESS BROADCASTER

No. Req'd.	Item
1	50B5 tube
1	35W4 tube
1	12AX7 tube
2	82 ohm 2 watt carbon resistor
1	1000 ohm 1 watt carbon resistor
1	10,000 ohm 1 watt carbon resistor
2	8800 ohm 1/2 watt carbon resistor
1	8200 ohm 1/2 watt carbon resistor
1	33,000 ohm 1/2 watt carbon resistor
2	220,000 ohm 1/2 watt carbon resistor
1	510,000 ohm 1/2 watt carbon resistor
2	1 megohm 1/2 watt carbon resistor
1	3.3 megohm 1/2 watt carbon resistor
1	15 megohm 1/2 watt carbon resistor
1	.000025 mfd. mica condenser
1	.00005 mfd. mica condenser
1	.0001 mfd. mica condenser
1	.0003 mfd. mica condenser
1	20-20 mfd. 150 v. electrolytic condenser
1	.25 mfd. paper condenser
1	.1 mfd. paper condenser
2	.02 mfd. paper condenser
1	.01 mfd. paper condenser
1	70 to 480 mfd. padder condenser
1	14-1040 Meissner oscillator coil
2	7 pin miniature socket
1	9 pin miniature socket
1	4" x 4 3/4" x 2" chassis
1	slide switch S.P.S.T.
1	closed circuit jack
1	open circuit jack
1	line cord and plug
1	2 1/2 mh RF choke
1	dual tie lug
1	5 terminal tie strip
1	standard phono plug hardware consisting of:
	12 each—4—36 x 3/16 machine screws and hex nuts; 2 each—flat and extruded fiber washers; 1—single tie lug; 1—3/8" rubber gromet

nected to a particular point, do your soldering when all wires are installed at that point.

After wiring filaments and line cord, mount padder condenser directly to pin #1 on the oscillator coil and the tie lug (Fig. 3). Mount this condenser with the end which contacts the adjustment screw connected to terminal on the tie lug. Turn adjustment screw out one full turn from the tight

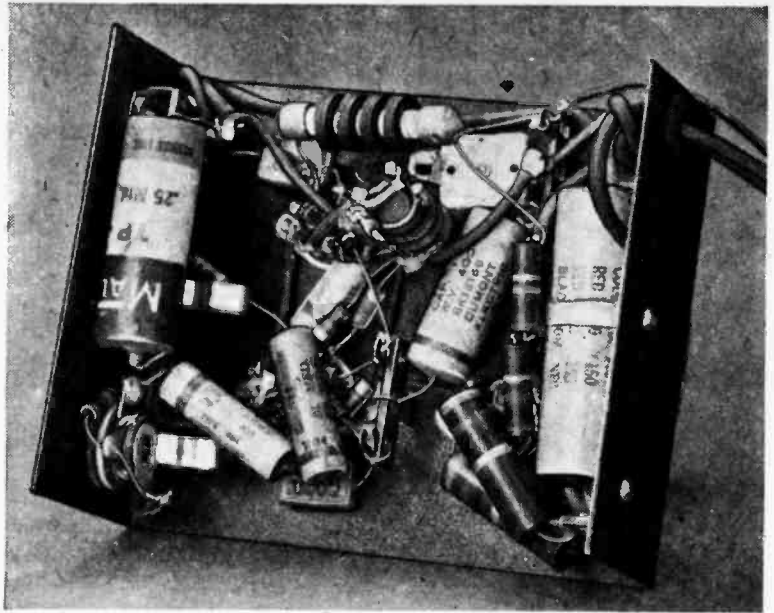
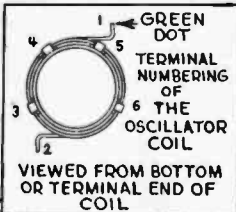
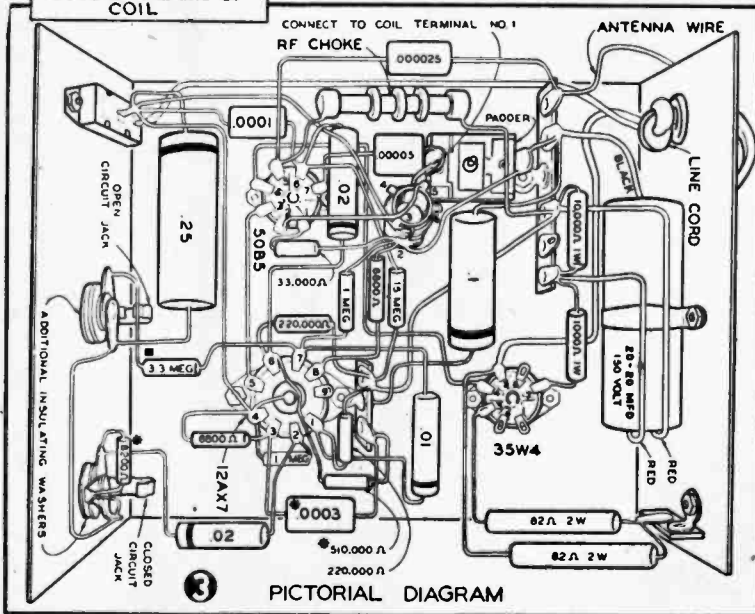

Fig. 2. Underneath view of the phono oscillator showing the wiring of the major components.



PICTORIAL DIAGRAM

position before installation. After installation, you can adjust this condenser with an insulated screw driver through the hole provided in the chassis. Black band around paper condensers (Fig. 3) designates end of condenser connected to outside foil. Finish wiring and use about 25 feet of any type of insulated wire for the antenna for the set.

Completed phono oscillator acts as a small transmitting station which can be tuned in on your radio set. It can be adjusted to operate at any frequency from 600 to 800 kc. or 1200 to 1600 kc. Tune receiver from 600 to 800 kc. or 1200 to

1600 kc. to find a dial setting where no station is heard. Place oscillator in operation by pushing slide switch to on position. Allow 2 or 3 minutes for tube to warm up. Uncoil antenna to a length of 10 ft. Turn phonograph motor on and set pickup arm on record. You may use a tone arm with a magnetic pickup (such as the G.E. or Pickering cartridges) or an arm with a standard crystal cartridge. Be sure to use correct jack for type of cartridge used. Using a small insulated screwdriver, tune padder condenser through opening in chassis until record is heard in radio. Tune radio to a local station and note volume of music being played. If a crystal cartridge is being used and volume of oscillator is much lower than the radio station, install a 1- or 2-megohm resistor in place of the 3.3 megohm resistor designated by the small square in the diagrams. If volume of oscillator is much higher than the radio station and there is much distortion, increase the value of the 3.3 megohm resistor.

Any type of high-impedance microphone may be used with this oscillator with the equalizer

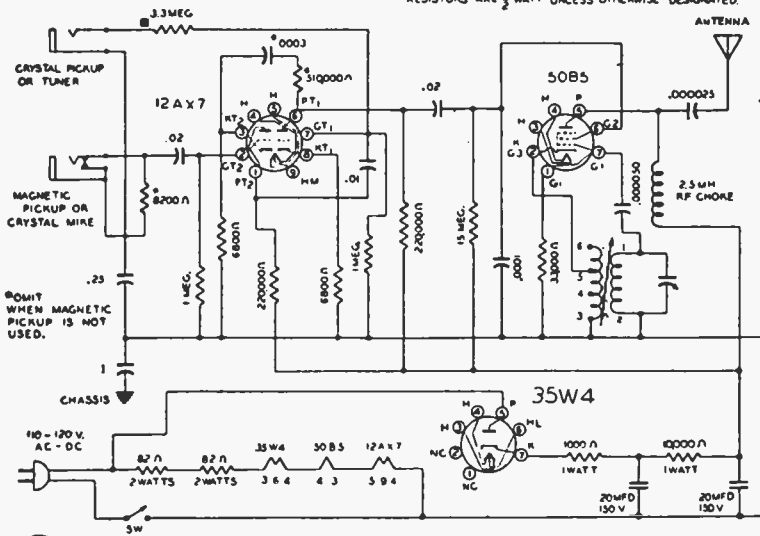

4 SCHEMATIC DIAGRAM

circuit removed. This circuit is composed of the 3 components (marked with a star on Figs. 3 and 4). The equalizer is needed only for a magnetic cartridge and should be removed whenever a microphone or a crystal cartridge is used. While any type of high impedance microphone may be used, the Electro-Voice "Century" model 915A is recommended, since it is fully insulated and shielded, eliminating the danger of shock.

The new-type magnetic pickups, such as those made by G.E. and Pickering, are designed to operate into a load of 5,000 to 15,000 ohms. This resistor is shown connected directly across input jack and has a value of 8200 ohms. Output of these magnetic cartridges is low, though higher at high frequencies than at low frequencies. The preamplifier raises the output voltage of the magnetic cartridge to a level at least as high as that obtainable from crystal pickups. Meanwhile, it compensates for the higher output voltage of the cartridge at higher frequencies. Remove the equalizing network and load resistor whenever a magnetic cartridge is not used.

When using a crystal pickup and with equalizing components omitted from oscillator, use a high impedance dynamic or crystal mike. Pickup and microphone signals are then electronically mixed within the oscillator and will be heard in the radio tuned to the oscillator. Either the padder condenser or the slug in the oscillator may be adjusted to change frequency. Adjust both padder and core to obtain best quality when oscillator is heard in the radio. Turning either the padder or slug too far in either direction will cause oscillator to stop oscillating. If radio has push-button tuning, set one button to phono oscillator; then adjust as for a radio station.

If oscillator is at some distance from the radio, you may need to unwind more of the antenna

wire attached to it. With sufficient antenna at the oscillator, background noise is minimized. As additional antenna is uncoiled, some change in tuning may take place, thus necessitating readjustment of phono oscillator tuning control or of the radio. Always adjust radio set for maximum deflection of tuning indicator or until record is clearly heard and with a minimum of noise. If there is a "howl" or a "whistle" in the radio while records are being played, frequency at which phono oscillator is transmitting is too close to that of a broadcast station, and it will be necessary to set

receiver dial at different position and readjust tuning control on the broadcaster. If excessive hum is presented in your radio when tuned to the phonograph oscillator (with no record playing), reverse oscillator plug in power outlet or socket. If hum persists, reverse power cord plugs on radio and phonograph, one at a time.

The ac-dc power supply in this set uses one side of the power line as a common ground

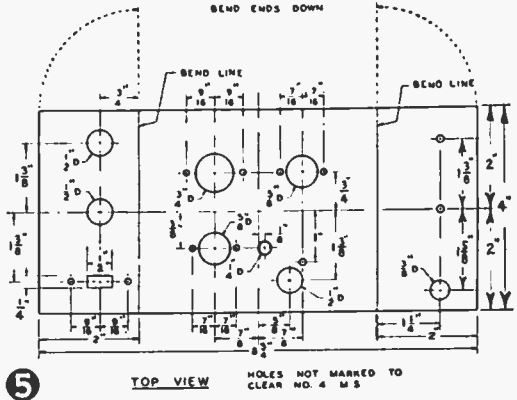

5 TOP VIEW HOLES NOT MARKED TO CLEAR NO. 4 M S.

which is isolated from chassis and microphone by the .1 mfd. and .25 mfd. capacitors. If you want to further reduce hum in the phono oscillator, short out these 2 capacitors to connect one side of power line to chassis and microphone or phono pickup. Shielded wire connected to either jack should be fully insulated so shielding cannot touch any ground object such as a water pipe. Also use a fully-insulated microphone.

● Complete wireless broadcaster kits may be obtained from Dept. 3R, Allied Radio Corp., 833 W. Jackson Blvd., Chicago 7, Illinois.

You Can Fix That Ailing Radio

Modern table sets are easy to repair once you know where to look for the trouble. Here are the cures for the majority of dead or sick small sets!

By T. A. BLANCHARD

WHO doesn't own—or know someone who owns—a small radio set that has gone dead, has become noisy or plays intermittently and is not repaired because the owner figures it isn't worth a stiff repair bill. Actually, because of the simplicity and basic uniformity in design of all small ac-dc radios, there is no reason why you can't take on the job of fixing that ailing set!

Let's get rid of the idea that elaborate test instruments such as signal generators, vacuum tube voltmeters, ohmmeters, or tube testers are required. Chances are you can locate the trouble and make the repairs needed with the tools you have, and you don't have to be an electronics engineer to repair a small radio—any more than a garage man must be an automotive engineer to replace a distributor condenser.

From the following check-list you can find the symptoms and probably the cure for most small radio failures. So long as you have not tampered with the capacitor screws in the I.F. transformer cans, or the trimmer screws on the set's tuning condensers, the check-list enables you to methodically track down the cause of any small set's failure to play. If, however, you have tinkered with the above adjustments, you'll have to take the set to an experienced radio technician for the cure.

To remove the chassis from the wood or plastic cabinet, first remove the knobs, which are secured to tuning shaft and volume control either by set-screws you can loosen, or, in more recent sets, merely pulled off the shaft. These pull-off knobs are secured by spring-blade tension, or knurled friction grooves. The chassis is secured either by screws under the cabinet, or by screws inside the cabinet, revealed after the back cover or loop antenna is removed. When you remove these, chassis slides freely from case.

Check all tubes first on a tube-tester at the radio store—usually there's no charge. Or use the pocket size tube checker presented on page 131 of this handbook. You'll need a neon bulb

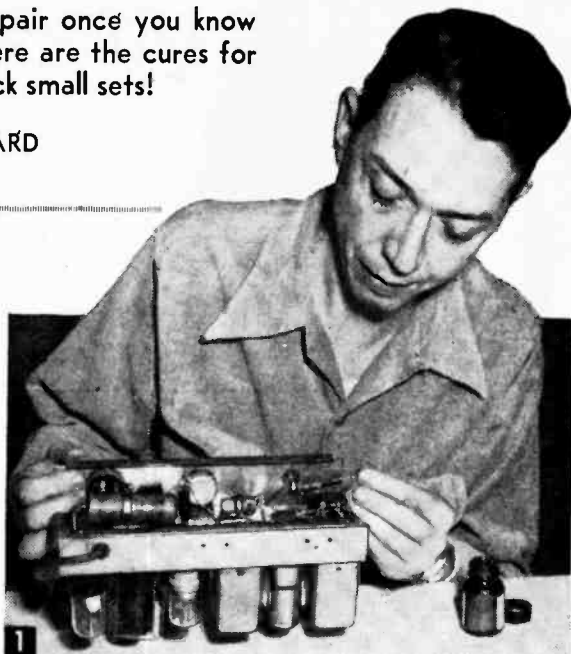

1 **DIFFICULT TUNING.** Slipping dial cord produces backlash. Apply mixture of 1 drop thick bone glue mixed with 1 drop glycerin to cord shaft of dial drive (See 1, Fig. 3). Or take up slack in dial cord caused by wear.

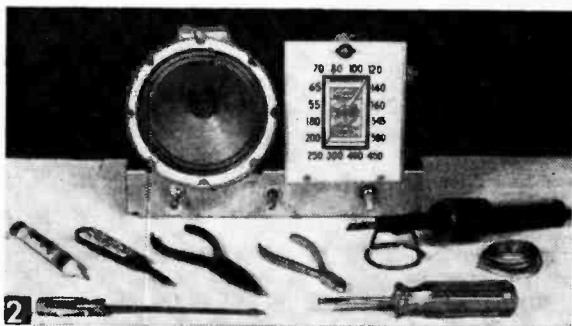

2 **TOOLS.** You need only a penknife, long-nose and diagonal "cutter" pliers, small soldering iron, 50-grade solder, small and medium blade screwdrivers for repairs. Dry graphite lubricant used on shafts.

continuity test set with two leads to check on capacitors, resistors and coils. After disconnecting one side of a suspicious component with a soldering iron, connect the clip and probe leads as shown in Fig. 7.

A broken wire, open resistor, or open capacitor will result in the neon lamp not glowing. The

lamp will glow across most good resistors, (except those over 10 megohms) and circuit wiring leads. Two tests, however, are required for paper capacitors. Both a good and shorted paper capacitor will cause the neon lamp to glow. First check the paper capacitor with a 1½ volt flashlight bulb and battery (Fig. 7A). If flashlight bulb lights when probes are connected across capacitor, throw the capacitor away—it's shorted!

If this test does not cause flashlight bulb to light, make the same test with the neon tester. If neon glows, capacitor is okay. If it does not, capacitor is open and must be discarded. A capacitor passes ac—stores up dc. Thus a good capacitor will not light on the flashlight test, but will respond to the ac neon test.

A small "multi-tester" with milliamperes, volts

(ac-dc) and ohms range to at least 1 meg. is a useful device for the serious radio experimenter. An instrument of this type is worth the cost (about \$15), but not essential for the repair problems outlined here.

Except for a defective line cord, all tests that follow are made with set disconnected from power line. After making a repair, never try out set with chassis resting on or near any metallic object, nor with your body in any way contacting any grounded object. Keep both set chassis and yourself "high-and-dry" from anything such as pipes, cement floors, lamps, and radiators.

TROUBLE CHECK LIST

Refer to Fig. 3 for letter references.

Receiver Dead. Check tubes for defects or burn-outs. One burned out tube in an ac-dc set causes all to go out (they're wired like Christmas tree lamps). Rectifier tubes are most frequently the offenders.

Check resistor in filter circuit between the two positive sections of electrolytic capacitor. This resistor varies from 1000 to 5000 ohms. Replace with new one near original value, and rated 2 watts. (See A, Fig. 3)

Check rectifier plate resistor. This is of low resistance—between 20 and 100 ohms. Replace

with new unit rated at 1 or 2 watts. (Not employed in all sets.) If set has only 4 tubes, look for open resistor in series with tube filaments (heaters). Often these resistors are too small to carry the load, and burn out. Replace with similar value rated 10 watts.

Shorted condenser across primary of output condenser. Disconnect one side of condenser to see if set now works. Replace when convenient with new unit. (See B, Fig. 3)

Open or shorted audio coupling capacitor. (Usually

TABLE A—TYPICAL RECEIVER TUBES AND FUNCTION

	Radio Frequency Amp.	Pentagrid Mixer	Oscillator	Pentagrid Converter	IF Amp.	Diode Det. AVC. AF amp.	Power Amp.	Rectifier
AC Sets—Pwr. Trans. Models	6SK7	6L7	6J5	6SK7	6H6 & 6J5	8L5	5Y3
AC-DC Sets with GT Tubes	12SA7	12SK7	12SQ7	50L6	35Z5 35Z4
AC-DC Sets with miniature tubes	12BE6	12BA6	12AT7	50B5 50C5	35W4
Battery Portables	1R5 1E8	1T4 1AD5	1S5 1U5 1T8	3S4 1AC5	*

* None, or Selenium rectifier if 3-way set.

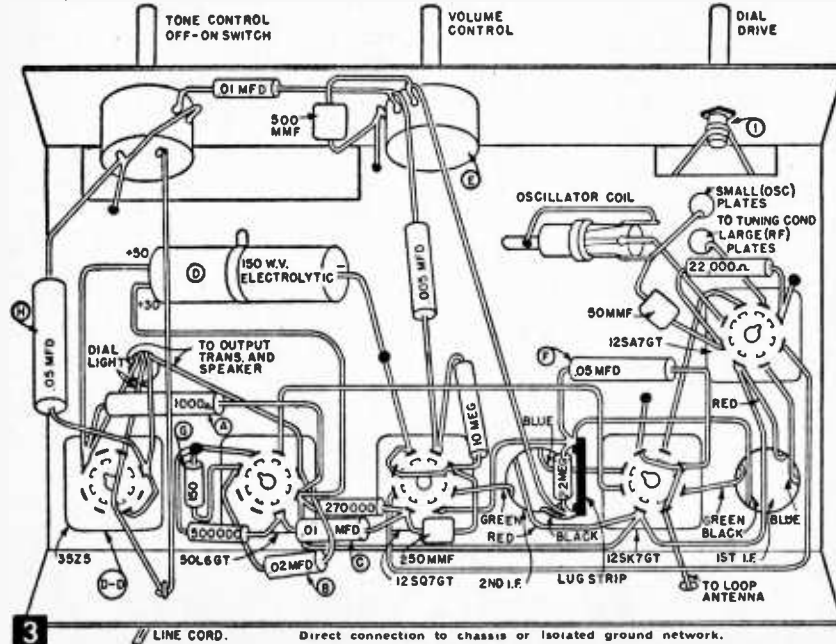

Key letters refer to most frequent set failures described in text. This picture plan shows GT-size tubes. However a set with miniature 7-pin tubes (battery or ac-dc) employs the same basic layout and components, differing only physically.

Rear view of typical dc-dc set removed from cabinet. Ultra-modern sets compare with this layout except for smaller tubes, I. F. transformers, tuning condensers; and ferrite "stick" antenna.

.01 mfd. between plate of the 12SQ7GT (or 12AT6) and grid of 50L6 (or 50B5-50C5.) Replace with new capacitor of value similar to original unit. (See C, Fig. 3)

Resistor, capacitor, wires, etc. accidentally touching chassis, or a cold solder joint often silence a set. Look for these small, but troublesome defects.

Check line cord for invisible breaks between set and plug. Be sure the outlet is not defective, nor that the trouble in the set is simply due to a blown line fuse. Check oscillator coil, and I.F. transformers for open in a coil winding. (You'll find that this is a rare condition, however.)

Noise. *Very Loud Buzz*, music scarcely audible. Defective electrolytic capacitor, or bad rectifier. Replace one or both. (See D-DD, Fig. 3)

Scratching noise while tuning set. Accumulation of dirt between the stator and rotor plates. Blow and/or brush out dirt. Small pipe cleaners are helpful in dislodging grime. Be sure no tuning capacitor plates touch each other. The phosphor bronze spring which grounds rotor plates to frame may be worn and dirty. A few drops of lighter fluid will dissolve the grime. If spring is excessively worn, solder a flexible "pig-tail" from rotor shaft to condenser frame to silence the scratching noise.

Scratching noise on volume adjustment. The 500,000 ohm potentiometer is worn out and requires replacement. In some instances where the back of this control is removable, a few "shots" of graphite lubricant will restore the control to good condition. Deposit graphite on "horse-shoe" element inside control. (See E, Fig. 3)

Hollow, bell-like ring or howl. A "microphonic" tube often shows no defects when tested even on a costly tube checker. Locating a tube of this nature is done with radio playing, volume turned low so speaker does not vibrate the faulty tube. With the rubber head of a pencil, ever-so-gently tap the glass envelope of each tube. Tapping the bad tube will create the howl. The slightest vibrations will carry over from a tube that is perfectly good to the culprit causing a false indication unless tubes are tapped gently.

Dirt in speaker voice coil. Most speakers are provided with a felt washer, or dust cover, to keep foreign matter from fouling the free movement of the voice coil. A set with distorted reproduction may have its cause in dust cover dropping off. Blow out all dirt and cement cover to speaker cone with a quick drying cement.

Defective Dial Lights. Broken or frayed dial

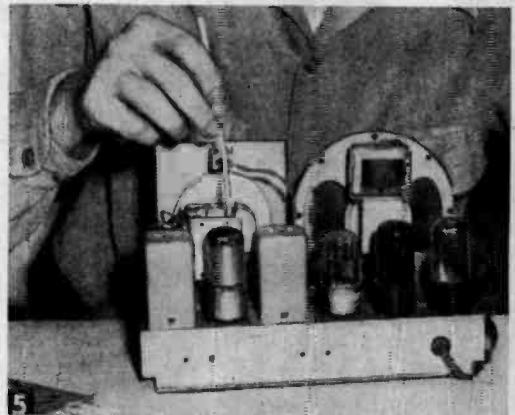
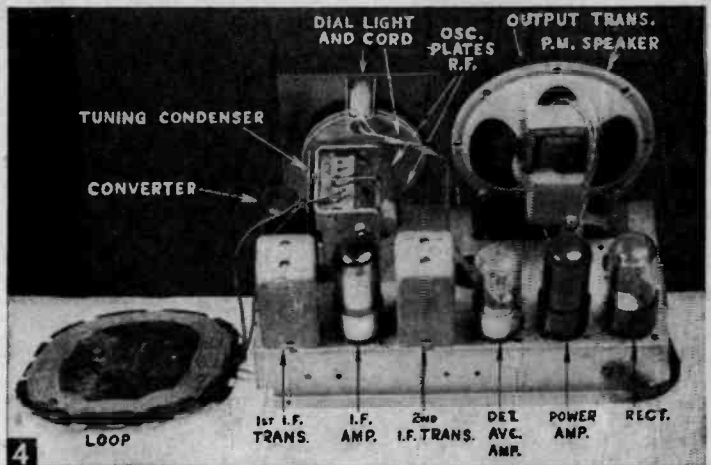

Dirt in gang tuning condenser plates is removed with thin pipe cleaners, aided by brush and blower. Check for rubbing plates.

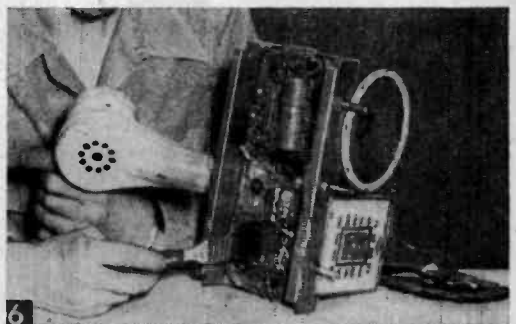

After removing chassis from cabinet, brush out all dust. Blower or vacuum cleaner exhaust help in expelling accumulated grime.

light leads, loose sockets, or dirty lamp contacts often create a racket as soon as volume is turned up. Clean and repair any defects found.

Other noises. Most small sets have a .05 mfd. capacitor across the line cord terminals to reject as much power line interference as possible. (See H, Fig. 3) Vacuum cleaners, electric drills and

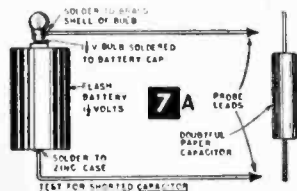
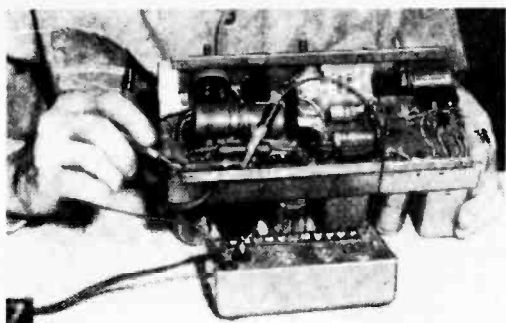

Continuity tests are made with neon test bulb of pocket tube-tester. It reveals defective resistors and capacitors. Left, flashlight battery test for "shorted" capacitors.

hand-grinders, shavers, hair-clippers, and magnetic contactors in oil-burners, motor starters, etc., create most man-made interference. Other interferences stem from X-ray machines, and arc welders or diathermy machines.

Intermittent Set Failure. In this group are the sets that play fine one minute—get weak, or go dead, the next. These intermittent conditions are not as difficult to locate as would be expected. Here are most of the causes:—

Check line cord for internal breaks by bending cord back and forth every few inches.

Speaker vibration causes wires or component leads to momentarily short against chassis. Also check for loose or broken lead from set to the loop antenna.

Defective grid return capacitor in first I.F. (12SK7 or 12BA6) or diode detector, AVC tube (12SQ7 or 12AT6). This capacitor is usually about .05 mfd. This symptom can usually be identified when set gets loud or soft as a light switch is snapped on or off. (See F, Fig. 3)

Intermittent audio coupling capacitor. (Previously described under Receiver Dead.) Instead of remaining open permanently, capacitor may have a thermal action caused by temperature changes. Replace if at all suspicious. (See B, Fig. 3)

Cathode Resistors and By-Pass Capacitors. Because of the low voltages required to operate ac-dc sets, only the cathode of the output tubes (50L5, 50B5 or 50C5) employ a current limiting resistor.

Sometimes the original resistor is too small to handle the current load. Replace with new 150-ohm resistor rated one-watt. (See G, Fig. 3)

Console type sets and deluxe table sets having power transformers to deliver higher circuit voltages, may employ several tubes having cathode resistors and by-pass capacitors. In these receivers, the cathode resistor is usually of ample wattage to handle the cathode current. However, the by-pass capacitor across these resistors is expendable. Check in particular the low voltage 5 to 25 mfd. electrolytic capacitor across the detector tube cathode resistor. In some sets this may also be a paper capacitor of .05 or .1 mfd. Defective by-pass will cause set to go from loud to soft and back again.

Dirty socket contacts or tube pins. Clean underside of chassis with a new paint brush to remove all dirt. If socket contacts are sprung, crimp each one slightly with long-nose pliers to insure firm pin grip. If socket contacts are dirty inside, clean with pipe cleaner dipped in carbon-tetrachloride, or lighter fluid. Look for "cold" solder joints on socket lugs. More poor connections occur on socket lugs than anywhere. Resolder all suspicious connections.

Grid resistors. These rarely cause trouble because of the very minute currents that pass through them. However, careless installation at the factory may cause a broken lead or cracked plastic jacket. Inspect all resistors for damage. Faulty resistors usually appear burned because they have been required to pass more current than their rating allows. If color code bands painted on resistor are scorched, replace the resistor with same ohms value, but double the watts rating of old part. Makers of low cost, mass produced midget ac-dc sets often sacrifice properly rated components in favor of a low price tag.

The above tabulation of receiver troubles should solve about 99% of the troubles that interfere with top radio reception. There is now the matter of replacement parts. Suppose you ask a

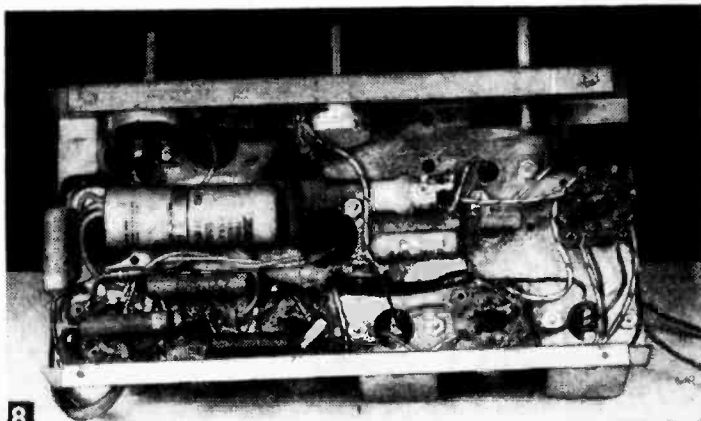

Actual bottom view of a 5-tube ac-dc superhet. Note that photo and pictorial plan are identical. Not all sets are wired as neatly.

parts supplier for a 50,000-ohm resistor because that was the value of the defective part removed from the set. He says, "Sorry, nearest I've got is 47,000 ohms." Fine, use it! It is safe to say that any resistor in a radio receiver may be varied at least 20% in either direction if the resistor value is over 5,000 ohms.

However, never accept a replacement for a low-ohm resistor if it is more than just a few ohms more or less than original. Making a radical resistance change in a low-ohm value can do two things: render the set inoperative, and/or burn up one or more components in the circuit to create a real repair problem.

For example, many pee-wee ac-dc sets employ but four miniature tubes; two 12v. tubes, one 50v., and one 35v. tube. The total series filament voltage is 109. As most utilities deliver between 115-125 volts to the home, these tubes would quickly burn out with no line-drop resistor in series with power line. Therefore, a 73-ohm 1.65-watt (minimum) series resistor is needed if line voltage is 120.

First, there is no 73-ohm value, nor a 1.65-watt resistor. What do you do? The radio supplier may have a 75-ohm unit which is rated at 5 watts. A slightly higher resistance value is better than a lower one, so use it! Moreover, the 5-watt rating insures a cool-running, long-life resistor. Always strive for a replacement part with a higher wattage rating than the original, and a slightly higher resistance (rather than lower) than original if exact resistance match isn't available.

If the parts supplier in your town isn't so well stocked, he will at least have 39-ohm, 2-watt resistors as this is a standard RTMA size. Connect the two 39-ohm resistors in series making a total resistance of 78-ohms, and you're in business!

Where you may desire some exact value, you can always connect any number of resistors of like wattage in series to provide the total ohms needed. Example: 33,000 and 56,000-ohm resistors connected in series make up an 89,000-ohm resistor, etc.

If a resistor of 2700 ohms, 2 watts is required, and your supplier has 1-watt sizes only, there is also a solution. First multiply the value of original resistor by two. This makes 5400 ohms. The nearest standard value will be 5600 ohms. Therefore, buy the two 5600-ohm, 1-watt units, and connect in parallel. Resistance will now be 2800 ohms, 2 watts—well within the circuit's requirements.

Capacitors do not present the critical condition which often exists with low-ohm resistors. Here, there is rarely any noticeable effect in reception by a wide variation in the value of a paper capacitor, or a modest variation in small mica or ceramic type capacitors. A larger or smaller value than specified can never do physical harm to the set.

With capacitors, it must only be remembered that if the unit is of the electrolytic type its polarity must be observed. That is, never install a

new unit with plus where minus lead was originally connected, or the reverse. Make a note of the defective condenser's position before removing for replacement.

Paper, mica and electrolytic capacitors usually carry a working voltage rating. The higher the working voltage, the more these components cost. Now, in the case of an ac-dc set as shown here, no capacitor need be rated higher than 150 w.v. Larger receivers (those with power transformers) will have capacitors rated 400 or 600 w.v. Usually these data are printed on the condenser jacket. Always replace with 600 w.v. units if this information is unknown.

With paper capacitors it is better—but not absolutely essential—to replace defective units with observance to the "outside foil" marking being the side of capacitor connected to ground. A black band around one end of paper capacitors also indicates "outside foil" lead.

Summing up, most small radio troubles are quickly discovered if the conditions experienced are compared with the trouble chart, and the component located on the typical chassis layout shown in accompanying illustrations.

From long experience, it has been found that defective tubes, resistors, and faulty capacitors lead all other radio troubles. Fortunately, these repairs are usually the simplest to make.

Modern Stand for Your Mike

• This adjustable, light mike stand can be made in a few minutes and for a few pennies. Obtain about 3 ft. of soft plastic-covered 6-gage solid copper wire, such as Roebing Roeplastic, in

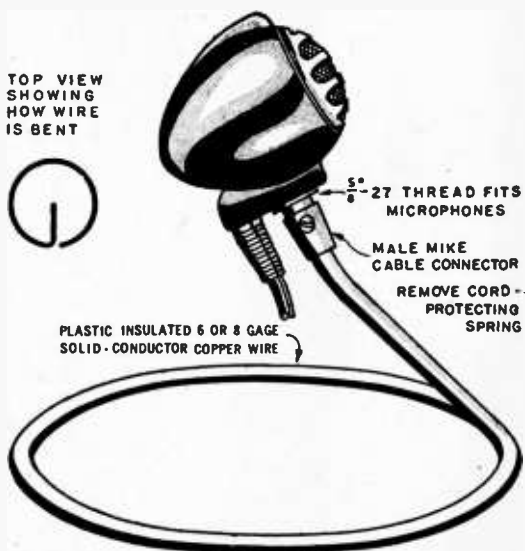

white or black from an electrical contracting firm. Bend stand as shown. Diameter of the loop can be 6 in. or larger, depending on the size and weight of the microphone and the builder's

taste. Slip a male plug, made for microphone cords, over the end of the wire and tighten the set-screw. These plugs have standard $\frac{3}{8}$ in.-27 threads which fit most American-made mikes.

If desired, use 8, 6 or 4-gage solid copper with

no insulation, and cover with soft rubber tubing. Aluminum clothes-line wire can be used but it is stiffer and harder to handle. The 6-gage version can even be coiled up and carried in a pocket.—A. TRAUFFER.

High-Powered Pocket Radio

In a Cigarette Case

Built from standard parts, this tiny set is completely self-contained except for headphones

By THOMAS A. BLANCHARD

MANY "pocket radios" designed for radio experimenters either require the use of bulky external batteries which defeat their claim to being pocket sets, or they are feeble crystal sets which can only pick up local stations, if used with outdoor antenna and ground wire connection. However, the true pocket set shown here (Fig. 1), with self-contained batteries, is built into a small plastic cigarette case. The parts are all standard items found in any radio supply catalog.

The circuit is very powerful and selective, with a single knob control which is merely detuned slightly if volume is too great for comfort on some stations. A flexible antenna with a clip lead permits the

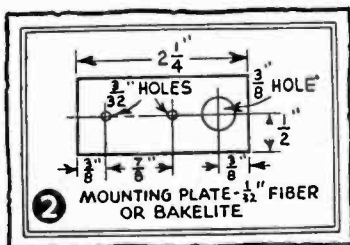

set to operate wherever there is a metallic object, such as the finger stop on a dial phone, a bed-spring, metal cabinet, metal floor lamp stand, window screen, fire escape, steam pipe or water pipe. No ground connection is needed.

Assembly of the set does not require working in tight places, since the set itself is a

complete chassis which is mounted in the plastic case after completion. The chassis is mounted on a $2\frac{1}{4} \times 1$ in. strip of $\frac{1}{32}$ or $\frac{1}{16}$ in. fiber or Bakelite. Drill 3 holes in this plate (Fig. 2). Two $\frac{3}{32}$ in. holes provide mounting for tube socket and tuning capacitor. The third hole is $\frac{3}{8}$ in. for clearing the tuner shaft, or access to tuner screw. The tuner is a 500 mmfd. mica trimmer type condenser with 2 metal tabs on the back to permit it to be mounted on a Z shaped mounting bracket which you can buy or make (Fig. 3). Make sure the trimmer screw is insulated from the top spring-leaf with a fiber, mica or porcelain washer. Most "trimmer" condensers are supplied with a mica washer.

Mount tuner as shown in picture plan (Fig. 4)

MATERIALS LIST—POCKET RADIO

- 1 plastic cigarette case, $2\frac{1}{2}'' \times 2\frac{1}{4}'' \times 1''$
 - 1 18 or 20 megohm, $\frac{1}{2}$ or $\frac{1}{4}$ watt resistor
 - 1 mica compression (trimmer) condenser: (approx.) 100 to 500 mmfd.
 - 1 33 mmfd. mica or ceramic fixed condenser
 - 1 400 mmfd. mica or ceramic fixed condenser
 - 1 coil (see text), or RF choke (Bud Ch-1212, etc.)
 - 1 Available for \$1 postpaid from E. G. Little, Mfrs., Springdale, Conn.
 - 1 7-pin miniature molded socket (Amphenol 78-7P)
 - 1 Olin Industries #0816 30 volt B-battery
 - 1 Olin, Bond, or Winchester penlite cell, $1\frac{1}{2}$ volt
 - 1 set 2000 ohm headphones
 - 1 1T4 miniature pentode tube
- Hardware: 1, 4-40 $\times \frac{3}{8}''$ screw and nut; 1, 3-48 $\times \frac{3}{4}''$ screw and nut. Strip $\frac{1}{32}''$ or $\frac{1}{16}''$ fiber or Bakelite, $2\frac{1}{4} \times 1''$. Small length of plastic hook-up wire. 1" soldering lug. 2 octal socket lugs for phone tip connectors. Small $\frac{1}{4}''$ knob. Standard "z" shaped mounting bracket.

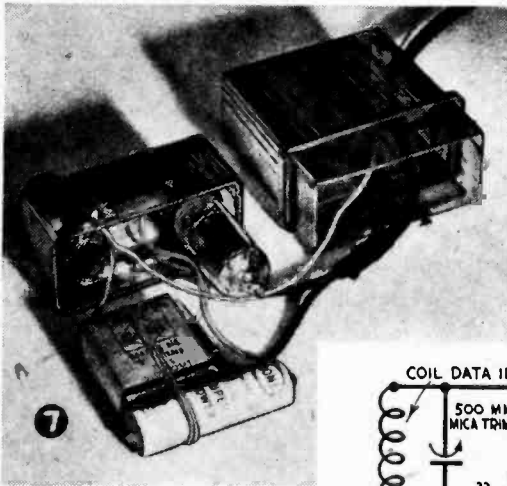
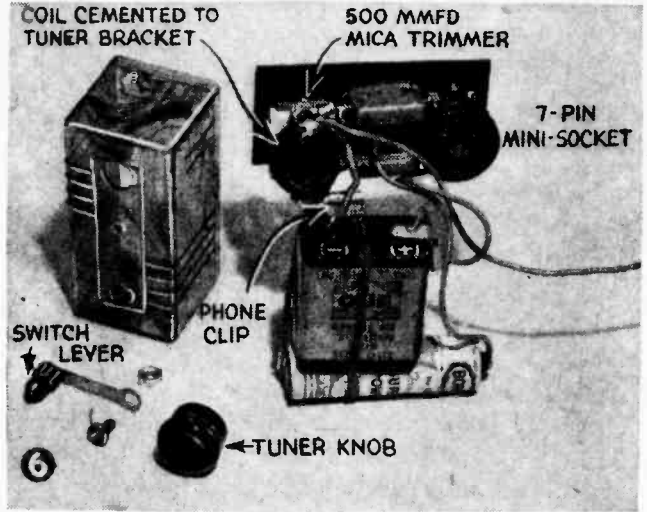
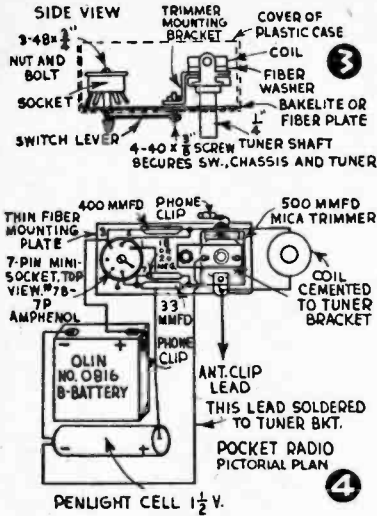

wound affair consisting of approximately 12½ ft. of 7-41 Litz wire, wound to form a bobbin about 5/8 in. dia. x 1/8 in. thick. Wind wire on a 3/8 in. dia. paper or plastic tube, and remove excess amount of tubing with a razor blade. Instead of the homemade coil, you can substitute a lattice-wound rf choke coil rated about 2.5 mh.

To mount the coil between lugs of tuner, first cement a 5/8 in. fiber faucet washer directly to tuner bracket with Duco-type cement (Fig. 3). Then cement coil to washer and solder coil leads to tuner lugs. Be especially careful when removing the insulation from the Litz wire, so that

each of the 7 fine strands of wire is clean enough to permit a good soldered connection. To strip off enamel place the wire lead on a flat surface and stroke with a fine steelwool pad, or draw the end of the wire through a folded steel wool pad held between thumb and forefinger.

A short, flexible hook-up wire permits the set to be easily connected to the batteries. The A-battery is an ordinary 1½ volt penlite cell. The B-battery is a new Olin Industries interlocked flat-type cell which, although only about 1 x 1¼ in. in size, delivers 30 volts and will last quite a while. The penlite cell requires more frequent replacement, but is very inexpensive. Bind the miniature Olin B-battery and penlite cell together with an elastic to simplify handling. Solder leads from the set directly to the A and B battery (Figs. 4 and 5).

Installation of a conventional switch in a set as tiny as this would be very difficult, so an ingenious, but simple, off-on switch is provided. Slip a 1 in. long spring-brass soldering lug under the tuner mounting screw and bend up the plain

using a 4-40-3/8 in. screw and nut. The 7-pin miniature socket is a regular Amphenol #78-7P designed for mounting in a 5/8 in. hole by means of a metal retaining ring. In this set, however, discard the ring and mount the socket to the Bakelite mounting plate with a 3-48-3/4 in. long machine screw inserted through the metal grounding ferrule in the center of socket. Before mounting the socket, make the soldered connection between pin #7 and the center ground ferrule. With tuner and socket mounted the set is ready for wiring (Fig. 5). Solder in components (Fig. 4) leaving the coil until last.

Clips for phone tips are pin lugs removed from an octal wafer socket and soldered to B plus and tuner lug (Fig. 4). Phones may be removed from the set without disrupting wiring. With battery leads and other wiring completed, the coil is ready for installation. The coil is a pie-

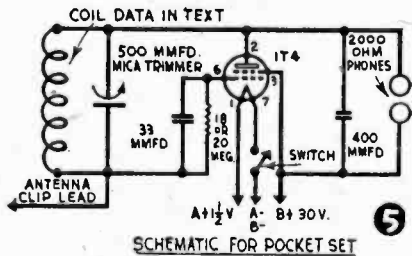

end 1/8 in. Purely for appearance, you can force a tiny plastic cap of the type found on lighter fluid and sewing machine oil cans on to the projecting tip of the lug. The nut securing the socket mounting screw serves as the lever switch contact. Solder the A-, B- lead to the tuner bracket. Thus, closing the switch so lever rests on the socket nut, the circuit is completed from tuner bracket, across lug, and from socket ferrule to tube #7. If a suitable soldering lug for the switch is not handy, use a shim brass strip.

Note that the tuner compression screw in the set pictured is fitted with a 1/4 in. shaft allowing a regular radio knob to be attached (Figs. 1 and 3). If a trimmer condenser is not available with shaft, tune the set with a small screwdriver. If detuning results, fashion an insulated screwdriver from a meat skewer by whittling a blade on one end. Or, attach the tuner's compression screw to a 3/8 in. length of brass rod to provide a shaft.

Set is now complete. Test it by attaching phones and a 1T4 miniature pentode. However, before inserting tube make doubly sure that battery connections are correct. Any voltage in excess of 1 1/2 volts applied to socket pin #1 will burn out the filament. Your dealer will make free replacement on any tube defects except broken glass and burnouts. Attach the antenna lead clip to telephone dial finger stop, if convenient, or regular outdoor antenna for initial testing purposes. If set is okay, mount it in

plastic cigarette case cover. First remove tuner mounting screw which now secures switch lever and bracket to Bakelite chassis. Drill 3 holes in the top of the plastic case identical to those drilled in Bakelite chassis (Fig. 6). Use care in drilling the plastic as it may crack when improperly handled.

For perfect holes, first drill 3 very small "pilot" holes, or heat a nail and burn or melt the initial openings. From here on it is a simple job to enlarge the tuner hole to 3/8 in., using either a rat-tail file or small pipe reamer. The center hole remains small to just clear the 4-40 mounting screw. The hole in the opposite end of plastic cover is also reamed out so that the entire socket nut will be exposed through the case as it is your switch contact.

Insert set in plastic cover, and replace 4-40 nut and screw to secure switch lever on outside of cover, as well as tuner bracket and set chassis inside cover. This one screw assembly makes service of set very simple. Ream a 3/8 in. hole in one side of the plastic case about 1/2 in. from the bottom, for the antenna clip lead and phone cord (Fig. 7). Attach cover carefully, so no components contact inside of case.

For maximum volume, use standard headphones of 2000 ohms resistance or more. Hearing aid type phones may be used if rated at 1000 ohms or more. For low resistance headphones a special output transformer is required or set will not work satisfactorily.

Aluminum Folding Rule Antenna

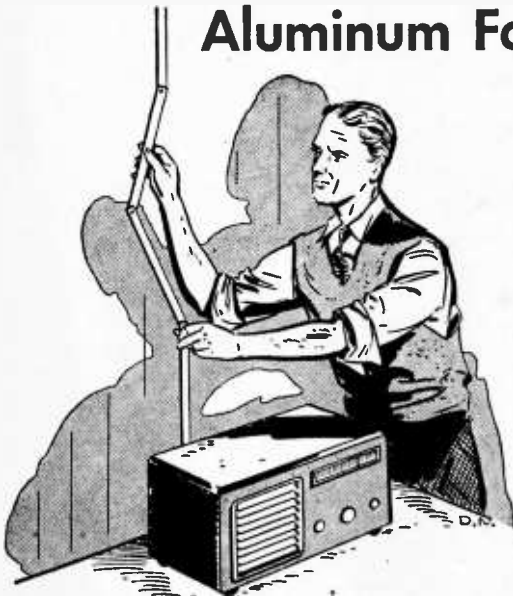

home radios with or without built-in loops.

If rule is not rigid enough to be self-supporting when the full length of 72 in. is used, and you cannot devise some way to give it additional support either vertically or horizontally, cut it off at the 48 in. length by filing off or drilling out the rivet. Also remove the rivet at 42 in. Using the rivet holes, mount the 48 in. length of rule to rear panel of radio with two 1/8 in. dia. roundhead machine screws. The rule should overlap at 42 in. just as it did before the rivet was removed. A lug under the 48 in. hole allows a lead to be connected from rule to antenna terminal. Use an alligator clip or split-lug for connecting this lead to antenna terminal. If receiver has a built-in loop on rear panel, mount rule away from loop by means of spacer-sleeves made from metal, fiber, or plastic tubing, and long machine screws.—ARTHUR TRAUFFER.

WHEN mounted on the rear of a radio cabinet, an inexpensive aluminum folding rule makes a good vertical antenna which can be unfolded to different heights and then folded back out of sight again when not in use. This compact antenna can be used on portable all-wave receivers, and on table or floor model

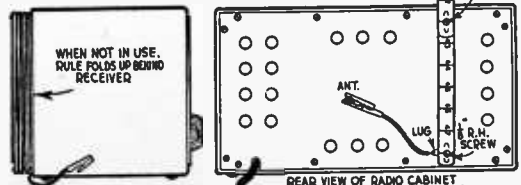

Dress Up that Low Price RECORD PLAYER

By ARTHUR TRAUFFER

LOW-PRICE record players are often sold minus everything but the bare essentials, as was the case with the one shown in Fig. 1. But suppose we see what we can add to this player which will improve it. First, let's purchase a chrome drawer handle (for about 25c) and mount it on the front of the player cabinet (Fig. 2).

The flocked finish on most low-price turntables is pretty hard and doesn't wear too long, so let's cut a heavy brown felt disc the same diameter as the turntable, cut a $\frac{5}{16}$ in. diameter hole in the exact center of the felt disc, apply a thin coat of LePages' glue (thinned with a little hot water) to the turntable top, and press the felt disc on evenly. This felt covering is easier on your records and also helps to reduce rumble.

For an arm rest and lock (Figs. 2, 3, and 6), which is handy when player is being carried, cut and drill a simple plastic strip as shown. Give the top of the strip a slight clockwise twist

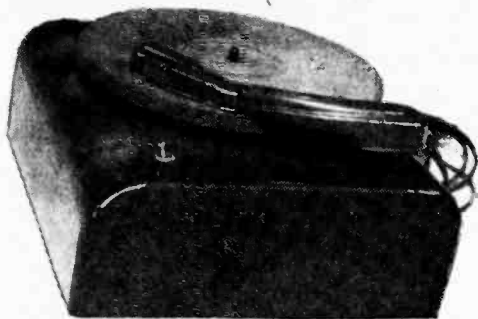

Fig. 1. BEFORE—record player as it came from the dealer.



Fig. 2. AFTER—all dolled up! Note chrome handle, layer of felt on hard turntable, arm rest and lock, and brackets for reeling up line cord and pickup cable.

so that it will line up with the side of the curved pickup arm. Remove crystal from the arm temporarily so that you can drill a $\frac{9}{32}$ in. hole through side of arm for a 6-32 rh (round-head) brass machine screw about $\frac{1}{2}$ in. long, a hexagon nut and a thumb nut (Fig. 4). Attach plastic arm rest to side of cabinet with two 6-32 rh brass machine screws about $\frac{3}{4}$ in. long, positioning the arm rest so that screw on arm slips into slot freely.

If player is to be carried about, you'll want to have line and pickup cords neatly coiled and out of the way. To do this, mount two simple S-shaped brackets on back of player cabinet (Fig. 5). Bend the two brackets from $2 \times 2 \times \frac{1}{2}$ - $\times \frac{1}{16}$ in. brass angle brackets (the dime store has them). Mount brackets about $7\frac{1}{2}$ in. apart with four $\frac{3}{4}$ in. long 6-32 rh brass machine screws.

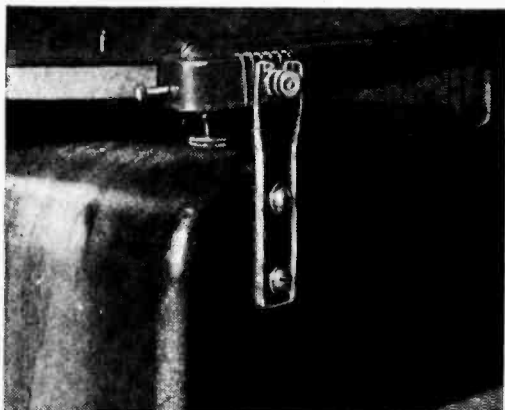
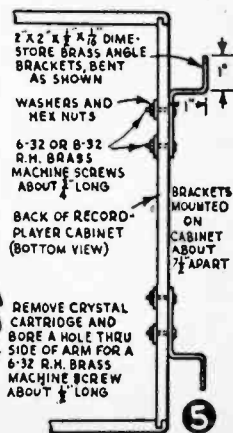
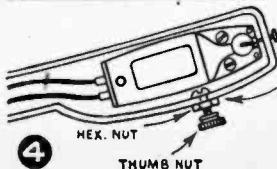
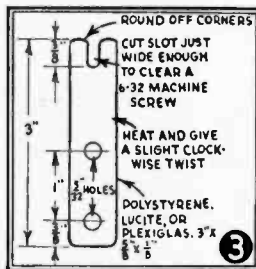
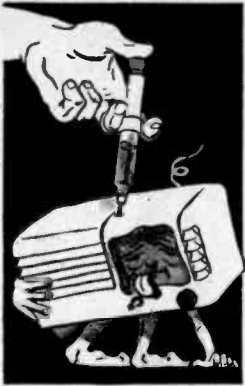

Fig. 6. Closeup of plastic arm rest and lock.





Inject New Life Into Junked Radios

Pull that old defunct radio out of the closet and modernize it for as little as \$7! You may find it better than the set you're now using!

By T. A. BLANCHARD

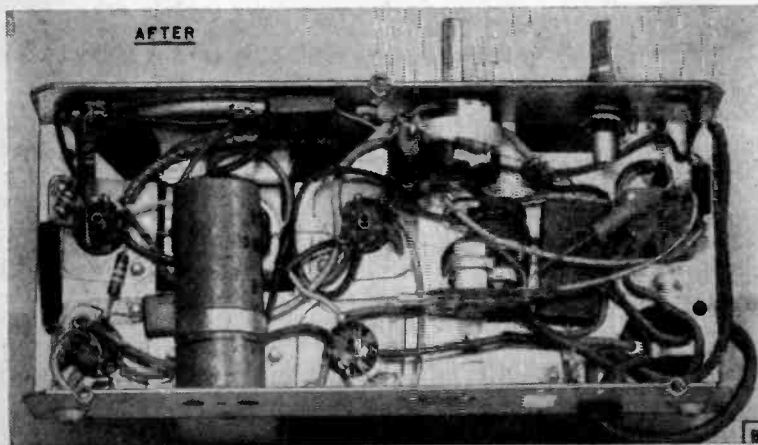
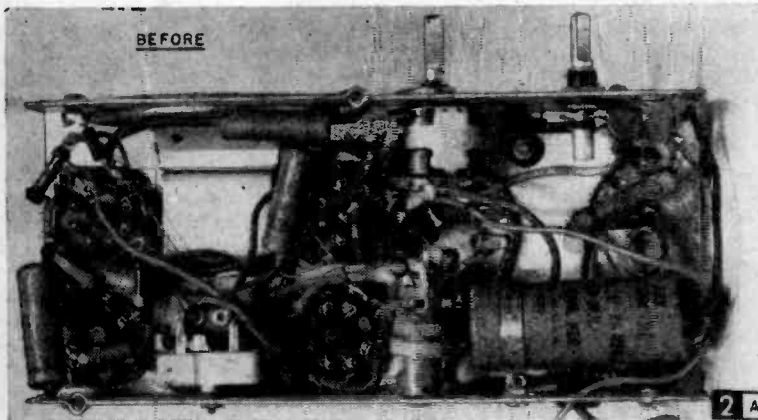

RADIOS long defunct in an attic or closet which some servicemen told you weren't worth fixing, can be rebuilt—and better than new. Rather than try to fix up an antiquated circuit, you can rebuild a completely new and modern circuit on the old chassis using about 75% of the original set components for a fraction of the cost of a new radio. The completed set costs about \$7.00 including tubes. Almost every radio dealer has all kinds of defunct "trade-ins" on hand available from gratis to \$2.00 or \$3.00. Because of high labor costs, dealers sell only trade-ins that work. The rest go to the junk man or the enterprising experimenter who asks to buy an old set "for parts."

If you shop for a junked set, select one with the best-looking cabinet and construction. The vital parts of the wreck you've purchased

(A) "Junk" chassis before being stripped of components. Note ready access to wiring and components after set has been changed to modern design (B).

MATERIALS LIST—CONVERTED RADIO

Note: Components listed are basic items. Refer to schematic or pictorial plan where other items are required.

- 1—Input I.F. transformer, 455 or 456 kc. high gain type (any make)
 - 1—Output I.F. transformer, 455 or 456 kc. high gain type (any make)
 - 1—"Hartley" type oscillator coil for 162 mmf. (max.) tuning, and 455/6 I.F. system. (Stanwyck #225, etc.)
 - 1—50 x 30 mfd. tubular electrolytic capacitor (150 w.v.)
 - 5—7-pin miniature molded sockets, saddle type top mount on 7/8-in. centers (Eby or Cinch)
 - 5—Electrolytic can mounting plates; 3-prong with 1/2 mounting centers, or 5—7-pin miniature sockets on standard 1 1/4 mounting wafers
 - 1—Ferrite antenna coil, or original set loop
- Tubes
- 1—12BE6 miniature pentagrid converter
 - 1—12BA6 miniature I.F. amplifier
 - 1—12AV6 miniature diode detector, amplifier, AVC
 - 1—50C5 miniature power amplifier
 - 1—35W4 miniature 1/2 wave rectifier

are still good, and the minor components would be discarded anyway for this conversion. Pick a set on *appearance*, and not because it might feebly play or happens to have a set of tubes in it.

The set rebuilt here was 15 years old, although even today it is still one of the smallest 5-tube sets ever made. In its worn out condition, heat from the compactly arranged GT-size tubes had melted the "potting" wax from capacitors and dried out the electrolytic capacitor. The top of the plastic cabinet was "cooked" to a dull finish. Knobs, mounting screws and one tube were missing.

The first job is to strip the chassis bare of all components except the 2-gang tuning condenser, speaker and volume control. Many of the components such as resistors and mica capacitors can be used again. Examine paper capacitors with suspicion if they show any sign of wax drip-

pings. Moreover, new capacitors are so inexpensive, it isn't worth the gamble to salvage anything but mica units.

You can remove the old wiring practically intact by grinding off the rivet heads which secure the old large-size sockets with an electric hand grinder. Another way to remove the old sockets is to drill out the rivets. Once the mass of wiring has been removed from the chassis intact, you can readily salvage the useful parts.

Gaping socket holes in the bare chassis may cause you to wonder how they can accommodate the tiny miniature units used in the converted set. If the old sockets are mounted on 1 1/4 in. centers, 7-pin miniature sockets on large GT-size wafers to fit the large holes are available from parts suppliers (Fig. 5B). However, sets of older manufacture (15-20 years) have sockets that mount on 1 1/2 in. centers (Fig. 5A). You can mount 7/8 in. molded miniature sockets over these 1 1/2 in. center holes on 1 1/2 in. metal mounting plates ordinarily used to install can type electrolytic capacitors. Your radio supplier can furnish mounting plates in metal or plastic. The Cinch or Eby socket fits nicely in the triangular hole of the capacitor mounting plate and is secured by drilling two 1/8 in. holes, spaced 7/8 in.

Mount either the 1 1/4-in. 7-pin wafer sockets, or the 7/8-in. sockets on capacitor plates with pins positioned (where possible) as shown in Fig. 3. Attach sockets with 1/4-in.—4-40 machine screws and nuts.

Discard the old I.F. transformers and the original oscillator coil in favor of modern high-gain I.F. transformers and an oscillator coil designed to work with present-day 455 or 456 kc. inter-

mediate frequency systems. You may have to punch new holes in the chassis you are converting to accommodate tubes or transformers.

I.F. transformers are available in several sizes. If space is at a premium, purchase the midget type. Otherwise, the larger size may be used providing the transformer is rated as high-gain, 455 kc. Some of the I.F. transformers have color-dot lug connections, some use colored wire leads and others have numbered lugs. Those with numbered lugs include an instruction sheet from the manufacturer identifying the numbers. The color-code is as follows: Red (B), Blue (P), Green (G), and Black (R) or (Gnd).

3 MODERN "SUPERHET" CONVERSION
PICTORIAL WIRING PLAN

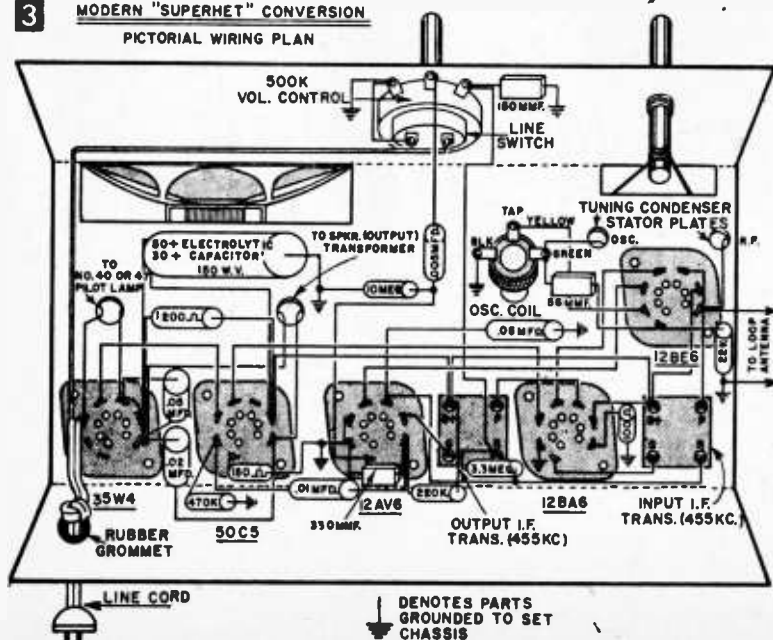

Standard brand transformers are packed with necessary code data to eliminate any doubt during hook-up.

If the set you are converting happens to have a few extra socket holes, just leave the unnecessary ones open, or use the blanks for mounting I.F. transformers. Some early sets may present superficial problems that are easily ironed out. While these conditions are not shown in the pictorial wiring plan, they are easily discovered "on sight" and corrected as explained in the following special points.

TRF SETS. You have a tuned-radio-frequency set if both sections of the tuning capacitor gang have plates of equal size per section. Also, there are no rectangular can I.F. transformers; just open coils. These TRF sets have no built-in loops but have instead either a hank of antenna wire or an antenna terminal. (Note: Some superhets have hank antennas—don't be guided by this alone.)

The point is—any set with a 2-gang tuning capacitor having plates of equal size is most likely 365 mmf. per section. You can use the front section of the 2-gang capacitor as is for the front R.F. tuning section. However, the rear section is too large and will not track. To reduce this section and properly tune the oscillator coil, install a padder or fixed mica capacitor in series with the lead going to oscillator stator of tuner. See schematic plan (Fig. 4) at (x). Value of the series capacitor can be approximately 200 to 400 mmf. if it is an adjustable padder, or approximately 270 mmf. if a fixed mica capacitor.

The modern oscillator coil tunes with a 115 to

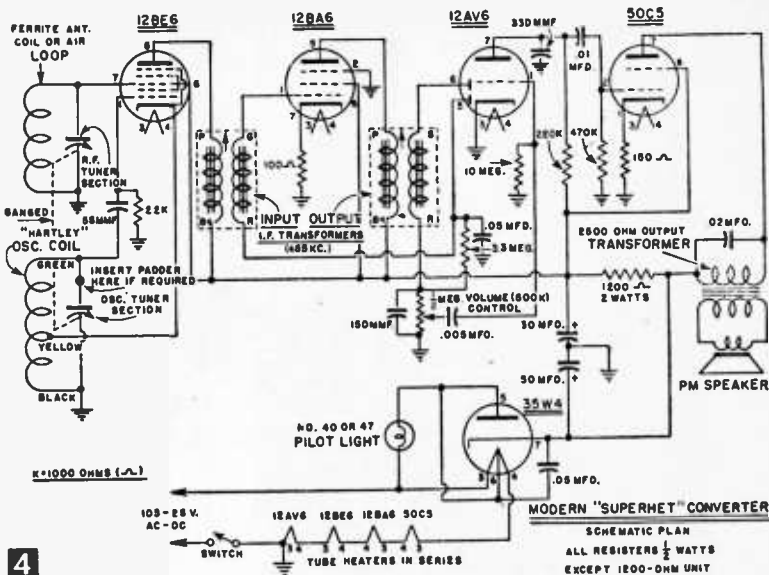

165 max. capacitance, thus the fixed or adjustable capacitor unit in series with the 365 mmf. variable unit reduces its maximum value to a usable size.

SPEAKERS. Many old TRF and superheterodyne receivers used a dynamic speaker rather than the modern self-energized PM speaker. Some very old sets may even have a magnetic speaker. Except for poor tone quality in magnetic speakers, any of the three types may be used in the converted set.

If the set being converted has a PM speaker, make connections as shown in Figs. 3 and 4. However, if the set used a dynamic speaker, you will note two extra wires coming from the speaker frame. These are the field winding leads, as this type speaker requires an external d-c source to energize it.

To obtain the d-c, merely connect these field wires in place of the 1200-ohm, 2-watt resistor shown in plans. With these connections the speaker field serves as a d-c filter while obtaining its excitation at the same time.

The magnetic speaker does not use an output transformer, since it has a high-resistance moving vane to drive the cone rather than a low resistance moving coil to drive the cone as in the case of PM and dynamic type speakers. Therefore, connect the leads from a magnetic speaker directly to plate of the 50C5 (pin #7) and cathode of the 35W4 (pin #7). Substitute an .005 mfd. capacitor for the

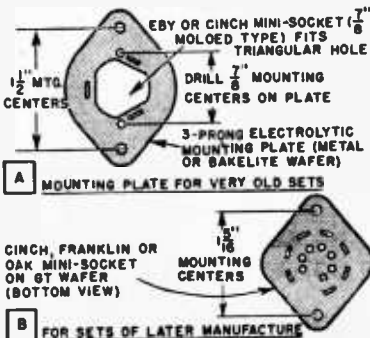
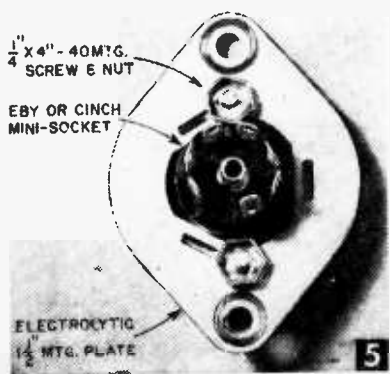

Mounting miniature tube in socket adaptor to fit chassis holes (left).

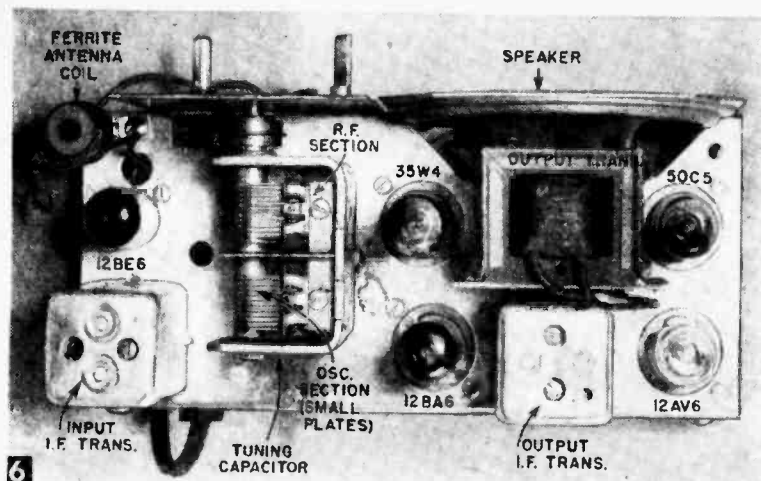

Modernized set; note miniature tubes located in same holes as old large-size tubes on adaptor plates. Open spacing allows new set to dissipate heat rapidly, insuring long component life.

.02 mfd. capacitor across the output plate and rectifier cathode when magnetic speaker is used. (We suggest the purchase of a PM speaker to replace the magnetic speaker whenever possible if the tone quality is important.)

PILOT LIGHT. Some old sets have no provision for a pilot light. Fig. 4 shows a pilot light which may be omitted simply by removing the lead from pin #6 and #5 of 35W4 rectifier tube, and connecting a lead from pin #3 to #5 of the same tube. Connect end of .05 mfd. capacitor originally on pin #6 to pin #3.

There is no necessity of purchasing new carbon resistors or mica capacitors because they vary somewhat from the "standardized" values shown. For example: if the R.F. mica filter capacitor across volume control in old set is 250 mmf. instead of 150 mmf. as depicted, use it! Ditto, all other resistors and mica capacitors shown as long as they are reasonably close. A 500,000 (500K) ohm resistor is just as good as 470,000 ohms; a 20,000 (20K) just as good as the 22K. You can substitute any value within reason. However, avoid radical changes!

Never try to salvage electrolytic capacitors. First, the old units were not capable of doing the filtering job of modern 50 x 30 mfd. units. More important, electrolytic capacitors dry out, often short and seriously damage rectifier circuit components. Most scrap sets in dealers' back rooms suffer only from defective electrolytics and resultant rectifier breakdowns. These faults and their antiquated design doesn't rule out complete reconstruction.

When you're ready to rewire the new-born chassis, start with the tube heaters (filaments). These heaters are wired in series starting with the 12AV6 detector wired with pin #3 connected to chassis as the first tube in the hook-up. This arrangement: 12AV6, 12BE6, 12BA6, 50C5, and 35W4 minimizes a-c hum from the power line

which is sometimes picked up by the 12AV6 detector tube if placed in the middle of the tube filament string.

Wire-in the remaining components using short leads wherever possible for neat and easily traced wiring. Ordinarily, length of leads is not critical, but the wire from G of input I.F. and output I.F. to their tube socket termination should be as short as possible. (See pictorial plan, Fig. 3).

This set usually requires no outdoor antenna. You can use either the very efficient ferrite core antenna coil or the original loop style antenna.

If your locality requires the use of an outside antenna, connect the antenna lead-in to pin #7 of the 12BE6 converter tube through a 200- to 330-mmf. mica capacitor. Loop or antenna coil must be in circuit for radio to work.

For purpose of wiring simplicity the schematic diagram (Fig. 4) shows the Hartley type oscillator coil rather than the Armstrong "feedback" type. The Hartley coil consists of a single tapped winding, rather than two separate windings. Some commercial coils are color coded: Tap or center cathode lug is yellow; ground lug is black, and grid lug green. The center lug will always be the connection to pin #4 of the 12BE6. If diagrams furnished with the coil do not explain the outer connections reverse the coil leads if set doesn't function properly.

I.F. transformers of modern design are either air-trimmer tuned fixed-iron-core or adjustable ferrite-slug tuned as shown in schematic plan (Fig. 4). Either type may be used so long as labeled "high-Q" or "high-gain" by the manufacturer. Using good components, the set should operate without any adjustment to I.F. transformer slugs or screws. To "track" the set with the dial, some slight adjustments can be made on the built-in trimmers found on the 2-gang tuning capacitor.

You will note that all negative connections shown in Fig. 4 are grounded directly to chassis to minimize wiring. Since the set being converted is housed in either a plastic or wood cabinet, this "hot" chassis hook-up is safe so long as there are no grounded metal parts, such as screws, exposed. Cover the screws securing chassis in cabinet with strips of plastic-backed adhesive tape or Scotch electrical tape. When testing exposed chassis, do not work on a metal-topped bench or table nor near water pipes, radiators or other grounded objects.

Because of the very small cabinet on the con-

verted set shown, a plastic handle from the dime store was added to help carry it around the house. Mounting holes for the handle were drilled before cleaning and polishing the cabinet. You can restore dirt and heat-marred plastic cabinets to their original luster by first scrubbing in a strong solution of a detergent such as

Tide. Allow cabinet to dry thoroughly before applying genuine liquid or paste wax (never synthetic self-polishing compounds). Allow wax to dry, then polish. Repeat waxing until bright luster appears. Clean and polish plastic dial windows with Glass Wax. Never use scouring powders on either cabinet or dial window!

Packet-Size URANIUM DETECTOR

Who said Geiger counters were costly?
Here's a reliable model which costs
under \$35 complete

By THOMAS A. BLANCHARD

HERE is a radioactive ore detector (Geiger counter) that works excellently despite its few components and minute dimensions. You'll find that it is easy to build and every bit as sensitive a detector as a \$100 counter. Parts for this unit may be purchased for under \$35. For information on how to use such Geiger counters to detect uranium ores, and the amounts offered by the government for uranium discoveries, see current government bulletins.

The complete counter is housed in a plastic card file box available at stationery and variety



Using uranium detector to locate lost radioactive material. A search for ore material would be more promising in a region full of granite rocks.

stores. The file box provides a low-loss container which is very desirable for the particular circuit used. The counter itself is mounted in the lid of the box. The high-voltage power supply just fits snugly in the bottom.

The minute size of this instrument is made possible by employing a high-voltage system similar to that employed in "voltage breakdown"



To charge capacitors, push lever switch down momentarily (left, above) so 2 paper capacitors are shunted across battery. When lever is returned to normal "up" position (right), capacitors arrange themselves in series with battery and counter registers radioactive material by clicking.

testing instruments widely used in the electrical appliance industry and by Underwriters Labs. Furthermore, our belief that this simplified high-voltage system was practical for a radiation detector was substantiated by material on battery-capacitor photoflash systems developed and furnished us by William H. Fritz, E.E., Manager, Battery Engineering Div., National Carbon



Detector case is opened to show location of components. Two capacitors (right) enable 300 volt battery to deliver 900 volts.

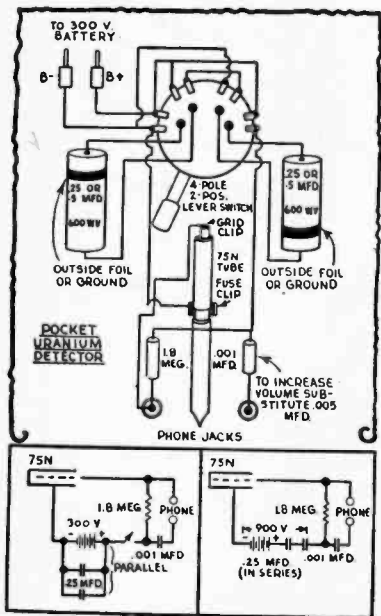

MATERIALS LIST—URANIUM DETECTOR

- 1 75N Counter Tube obtainable from Amperex Electronic Corp., P.O. Box 418, Hicksville, L. I., New York, for about \$10.
- 1 Eveready Minimax #493 battery (about \$7.70). If this is not available from your usual suppliers, write Sales Dept., National Carbon Co., 30-A East 42nd St., New York 17, N. Y., for source of supply nearest you.
- 1 set Cannon EC-2 Empire headphones
- 1 plastic file box or a container homemade of plastic or kiln-dried plywood coated on all sides with Wipe-On Bakelite varnish
- 1 Mallory #6242 lever switch, 4 circuits, 2 position, non-shorting type
- 1 pair phone tip jacks
- 1 Amphenol 78-1M Black battery plug (negative)
- 1 Amphenol 78-1L Red battery plug (positive)
- 2 paper capacitors (condensers), .25 mfd. or .5 mfd., 600 w.v.
- 1 .001 mfd. 400 w.v. condenser (or use .005 for greater volume)
- 1 1.8 megohm, 1 watt resistor
- 1 radio tube grid clip (GT size)
- 1 automotive or "Littlefuse" clip
- Misc. high-voltage hook-up wire, plastic drawer pull, 3 4-40 x 1/4" screws and nuts, 2 #4 self tapping screws, strip of aluminum

Co., New York. *Author's Note:* This project would not have been possible without the excellent co-operation given us by the Engineering Dept. of Amperex Electronic Corp., and National Carbon Co.

Fig. 1 shows how a single Eveready #493 Minimax 300 volt battery delivers up to 900 volts for operating the Amperex 75N tube. Two 0.5 or 0.25 mfd., 600 w.v. paper capacitors are shunted across the battery when the lever switch is down (see photo). The switch lever is returned to its normal up position, causing the two capacitors to arrange themselves in series with the battery as shown in Fig. 2. While in parallel with the 300 volt Minimax, each capacitor becomes charged with a 300 volt potential. Each capacitor will hold a charge up to 30 minutes. Thus for up to 30 minutes the 75N Amperex tube will be sensitive to radiation. However, when in a radioactive field, the high voltage charge will leak off more rapidly since

the tube is firing. But the strong clicks in the phones are restored simply by pushing the switch down for a moment to recharge the capacitors, then pulling it up again.

The simplified schematics (Figs. 1 and 2) best illustrate what is accomplished by the lever switch. It is important, therefore, that the right switch is used and that connections are made exactly as shown in pictorial plan. The switch is a Mallory #6242 4-circuit; 2-position, non-shorting type, which may be ordered from any radio supply house.

Drill a series of small holes in the plastic box and remove separations between them to provide a slot for the switch lever. An auto ignition file was used to finish the slot. Drill two 1/8-in. holes in the box cover for mounting the switch. Then drill another 1/8-in. hole in center of cover for mounting a "Littlefuse" or similar automotive-type fuse clip. The Amperex tube's cathode clip into this holder. A standard radio grid clip

is used to connect to the tube's *anode*. Drill two ¼-in. holes at opposite end of cover for mounting a pair of radio earphone tip jacks. Note that front of box actually is top of finished instrument. Attach a dime store plastic handle flush with the box edge.

Next mount a 4 x 1¼ in. aluminum strip under the handle to provide both reinforcement and a cover lock. Drill two ⅜-in. holes for the handle and, in the cover edge, two ⅛-in. holes for securing cover to projecting edge of aluminum handle reinforcement strip. Two small self-tapping screws secure the cover.

Remember that all leads in the circuit must be insulated and wired in neat orderly fashion to prevent high voltage charge in circuit from "flashing." Use good quality high-voltage insulated wire. Also remember that you don't want to go probing around the circuit because there is a potential of 900 volts that has more kick than a Missouri mule. Although small in size, the #493 Eveready Minimax battery delivers a shock more severe than you get from a 110 volt home line. To prevent shocks, don't attach fuse clip which secures Amperex tube directly to box cover (as was done here), since touching this nut will discharge the counter and kick severely at the same time. Your radio dealer will supply a fuse clip which you saw in half just above the hole in its Bakelite mounting strip. If you attach the Bakelite to the cover with a screw and nut, the fuse clip will be fully insulated and thus harmless.

You won't need to disconnect the battery until you have to replace it, since, once the charge in the capacitors has leaked off, the circuit will no longer draw current. In addition the amount of current consumed by this circuit is so small that the Minimax battery in use will last almost as long as it would lying unused on a shelf.

To test your completed counter, connect headphones to jacks, push down switch lever for a moment, then return to normal up position. If you have an alarm clock with a radiant dial, move it close to the counter and a series of sporadic clicks will be heard in the phones. These clicks will decrease as the clock is moved away from the counter.

Note that even without an active field available, you can determine if the counter is working by a background count of infrequent clicks that is always present. The background click will occur once every 15 seconds to 1 minute, depending on conditions where you are located. However, this count is not confusing because the counter will crackle like bacon and eggs frying when it is in the field of radioactive matter.

A list of radioactive materials which prospectors can use for testing Geiger counters is available from the Atomic Energy Commission, Document Sales Agency, Oak Ridge, Tenn. A handbook entitled, "Prospecting for Uranium," may be bought from Supt. of Documents, U.S. Gov't Printing Office, Washington 25, D. C. The price is 35c money-order or cash.

Will it work?

To solve your problems with minimum trial and error—to be sure your improvements will work, turn to these outstanding books.

Television for Radiomen

By Edward M. Noll. Explains very clearly what the function of each element and circuit in the TV set is; how to spot, test for and correct malfunctioning; how to make improvements. Handy tables make the necessary calculations easier. You'll gain a really thorough understanding of TV from this "refreshingly clear" book.



Radio & TV Mathematics

By Bernhard Fischer. Arranged under radio topics for quick reference, over 700 specific examples show you what formulas to use, what numerical values to substitute, and each step in the solution of all ordinary radio and TV problems requiring math.



Mandl's TV Servicing

By Matthew Mandl. This most complete, up-to-date, practical book tells you what faults can occur in each TV receiver circuit, why they occur, how to recognize and overcome them. Includes a complete master trouble-index and hundreds of diagrams, scope patterns and other illustrations.



TV & FM Antenna Guide

By E. M. Noll & M. Mandl. Shows you how to decide on the best type of antenna and the best position for it, how to minimize interference, avoid ghost reception, get the most out of the whole antenna system at any site, with special attention to fringe areas and difficult sites.



Introd. to Practical Radio

By D. J. Tucker. Thorough, clear explanations of all radio essentials, the construction and operation of basic parts and circuits and their use in commercial equipment. The necessary math is explained at the points where it is used. One of the most widely used texts on radio principles.



SEE THEM ON APPROVAL

Please send me the books I have checked. I will either remit in full or return the books in 10 days.

- Television for Radiomen \$7.75
 - Radio & TV Mathematics \$8.75
 - Mandl's TV Servicing \$5.50
 - TV & FM Antenna Guide \$6.25
 - Introd. to Practical Radio \$5.00
- Signed.....
Address.....

(This offer good only within the continental limits of the USA)

THE MACMILLAN CO., 60 Fifth Ave., N. Y. 11, N. Y.

Twin Speakers Improve Fidelity

IF YOU have twin 6 or 8 in. P.M. type speakers, it's an easy job to connect them in series at their voice coils, and their combined performance will sound very much like one expensive speaker of twice the diameter. The two-speaker combination will, in fact, reproduce any audio signal with less distortion. Costwise, the two small 6 in. P.M. speakers cost about the same as one large 12 in. speaker.

To connect the small speakers in series, first mount them on a single baffle of suitable size (preferably of $\frac{1}{2}$ in. insulating board).

The important thing to consider when connecting the voice coils is their correct polarity with respect to the operation of the cones. They must work in phase, that is, both cones must be pulled in and pushed out together, on each impulse of the signal, or vibrate together, rather than have one pull in and the other push out. To do this, use a flashlight cell and 2 clip leads to test the operation of each cone (Fig. 1). With the positive, (top of cell) connected to a certain voice coil terminal, the cone will be pulled in. If you reverse the battery polarity, the cone will be pushed out. Mark the terminal used when the cone is pulled in with positive polarity on that terminal. Do the same thing to the other speaker. It is now a simple job to connect the two voice coils in series (Figs. 2 and 3), connecting a positive to a negative. Solder on long leads for connection to the output transformer. Then double-check by attaching the battery to the long leads, and make sure that both cones pull in and push out together, with a reversal of the battery leads. The two speakers will now operate as a single unit, each taking half the power output, which doubles the capacity of a single speaker of the same size.

For good bass reception, speakers should have a rather flexible cone mounting, since bass is at the lower frequencies where the maximum cone movement is evident. Many speakers will be found with very stiff working cones, easily determined by gently pushing in at the center with a finger. Such speakers work all right at the higher frequencies, but may lack good bass re-

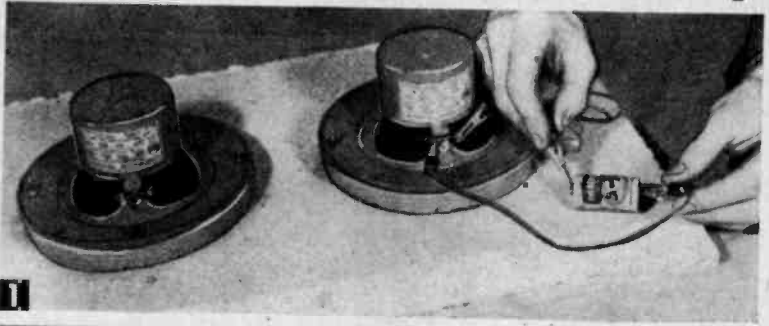

1

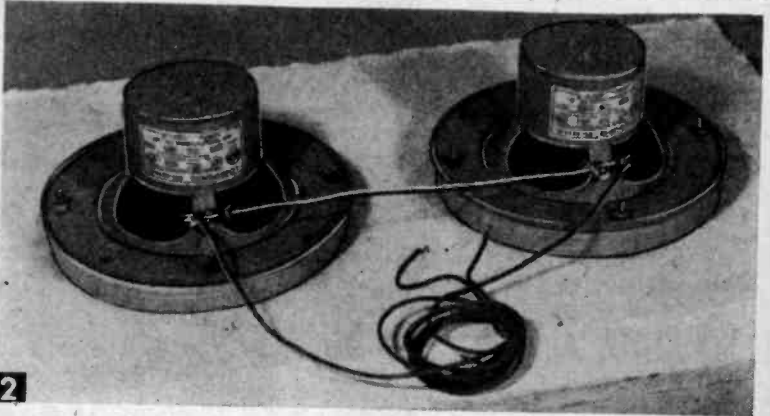

2

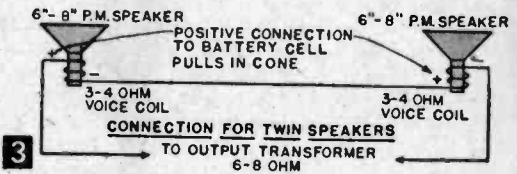

3

sponse. In the past, speakers were made with a flexible leather mounting ring at the edges of the cone to improve the bass. The two shown in Figs. 1 and 2 have bellows-like construction at the edge, rather than the usual direct mounting to the frame, to provide a more flexible operation of the cones.

For good fidelity choose a good quality output transformer of generous size, since a cheap, small transformer will often fail to cover the wide frequency band of the signals delivered to it, if the full range of the musical scale is desired. The transformer must also match the rated load resistance of the amplifier output tube or tubes in the circuit, to the voice coil impedance. For example, a 6V6 with 250 volts on the plate requires 5000 ohms load resistance. Using the twin speakers, each with a 3-4 ohm voice coil, this becomes 6-8 ohms in series. Thus, you must match 5000 ohms to 6-8 ohms on the secondary of the transformer.—HAROLD P. STRAND.

Loop Crystal Set

Just aim the loop at the station you want, and then enjoy yourself

By ARTHUR TRAUFFER

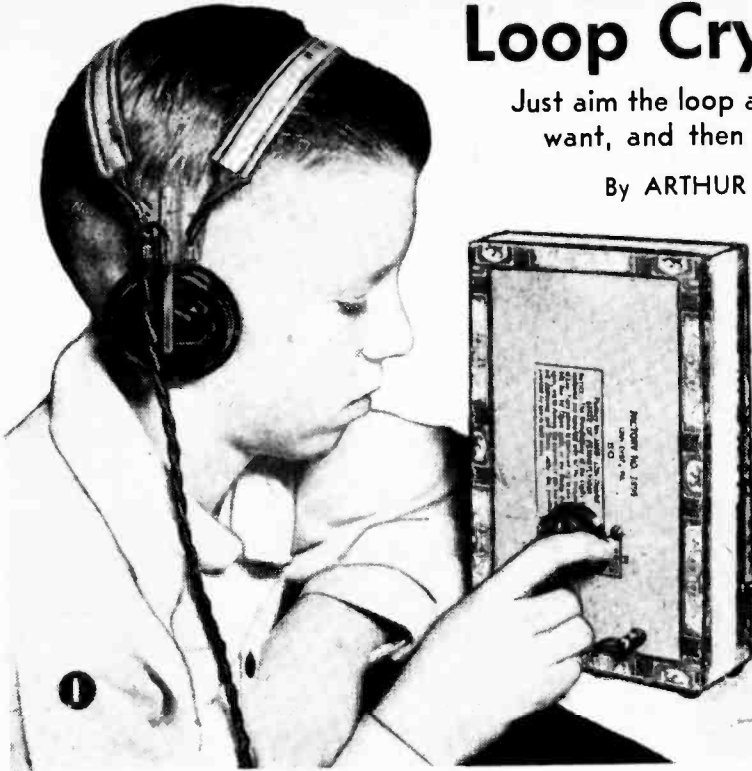

watt stations, no conventional antenna or ground is needed. The loop crystal set can be carried around playing, and used anywhere in the house; just aim the loop at the desired station.

Interfering stations, which are at right-angles to the desired station, can be greatly reduced in volume simply by pointing the loop at the desired station with the loop broadside to the interfering station. In some cases, a loop crystal set will prove to be more selective

than most crystal sets using a conventional antenna and ground, but don't expect the same sensitivity with a loop that you will get with a long outside antenna and a cold water pipe ground. A binding post on the side of the cabinet provides for an additional antenna for those living outside the range of the loop, and for those desiring to pick up more distant stations after the locals have signed off for the night.

The extreme simplicity of this set is demon-

IN THESE days of powerful transmitters, sensitive germanium diodes, and sensitive earphones, a loop crystal set for local stations is practical and sometimes a distinct advantage. For example, for those living within about 4 miles of 5,000 watt stations, and 5 or 6 miles from 50,000

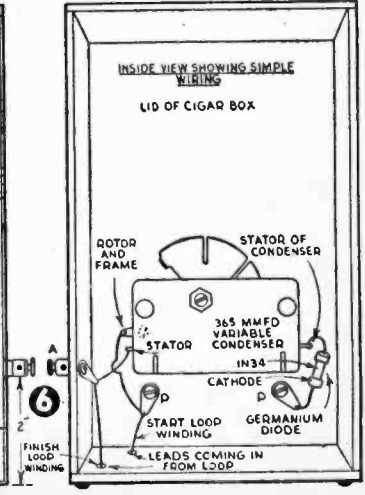
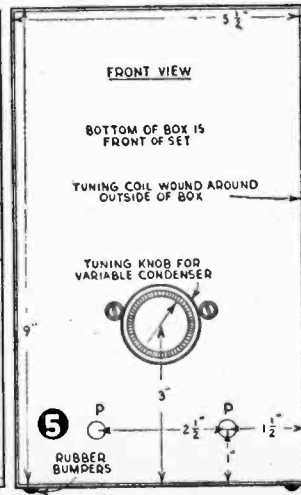
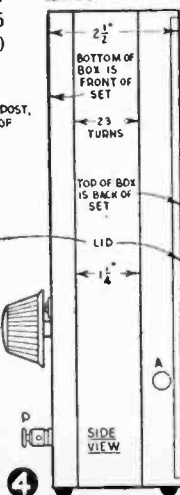
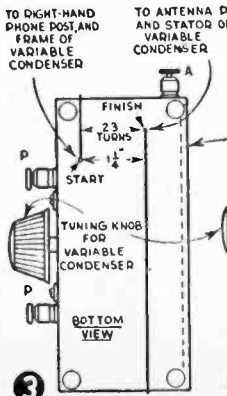
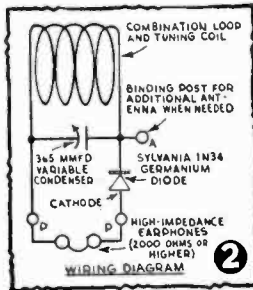

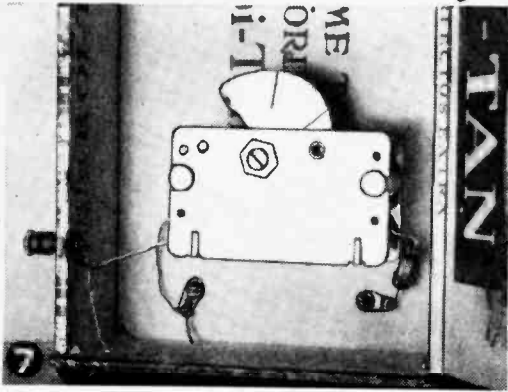

strated by the fact that the set shown (Fig. 1) was assembled and wired by a child under the supervision of the author.

This set differs from other crystal sets in that the tuning coil is wound around the outside of a cigar box to form a loop antenna (Fig. 2), instead of on a small Bakelite or cardboard tube inside the set. Figs. 5 and 6 show the simple layout for the 365 mmfd. variable



condenser, the 3 post-type binding posts, or Fahstock clips for the earphones, and the extra antenna connections. Fasten a soldering lug under the head of each binding post screw. Wind the loop, consisting of 23 turns of #24 gage enameled or double-cotton covered magnet wire, around the outside of the cigar box (Figs. 3 and 4). To start loop winding, connect to right-hand phone post (as seen from front view of set) and to variable condenser rotor and frame (Figs. 3 and 6). Then wind 23 turns clockwise around outside of box and connect the other end of loop

MATERIALS LIST—LOOP CRYSTAL SET

- 1 5½" x 9" x 2½" cigar box
- 1 365 mmfd. variable condenser, single gang, any good make. The one used by the writer was made by Insuline
- 1 Sylvania 1N34 germanium diode, or any other sensitive crystal
- 60 ft. No. 24 or 26 enameled or double-cotton-covered magnet wire
- 3 post-type binding posts or Fahstock clips
- 3 soldering lugs
- 4 small rubber bumpers
- 1 Bakelite knob or tuning dial for ¼" shaft

to antenna post and stator of variable condenser. The width of loop winding will be about 1¼ in. with the turns spaced the diameter of the wire apart. Connect germanium diode cartridge from another variable condenser stator lug to left-hand phone binding post (Figs. 6 and 7). Mount a pointer knob or a graduated turning dial, on the variable condenser shaft, and tack or glue 4 small rubber bumpers onto the bottom of the cabinet. The set is now completed (Fig. 1).

Wind a few turns of Scotch tape over the loop wires to protect the wires (Fig. 8), or brush a couple of coats of shellac over the loop wires. The writer tried shunting a small by-pass capacitor across the phone terminals, but no improvement was noted. This loop crystal set will give you slightly more volume indoors than outdoors, due to RF energy picked up by induction from the house wiring circuit. There will be some variation in signal strength in different parts of the room and different rooms in the house, due also to the house wiring circuit.

Glue a disc of heavy white paper or thin white cardboard onto the panel under the pointer knob on the tuning condenser so you can log your stations. When an additional antenna is used, however, the log will shift somewhat due to the added capacity introduced into the tuning circuit by the antenna. A water pipe or gas pipe connected directly to the antenna post makes a very efficient antenna for picking up distant stations. To obtain better results on distant stations connect a water pipe to the antenna post and use a bed spring as a counterpoise. Connect the bed spring to the right-hand phone post, which is the other side of the loop.

If you use a variable condenser larger than the one specified, you may have to remove 1 or 2 turns from the loop in order to cover the entire broadcast band. If you use a smaller capacity condenser you may have to add 1 or 2 turns to the loop. It is best to use a condenser not smaller than 365 mmfd., which is a standard size for the broadcast band. A little experimenting will give the desired results.

Auxiliary Auto Aerial

• An auxiliary aerial for trips, when you are away from broadcasting stations, can be added to your car radio if you have a luggage carrier on top of your car. String an insulated wire back and forth between carrier crossbars and attach one end to regular aerial with a small clip.—W. H. McCLOY.

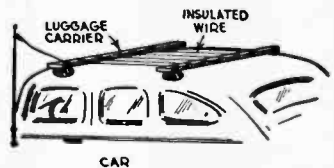

Copper Away

• A machine gun in four minutes uses 30½ pounds of copper, enough to stretch a mile and a half as wire the thickness of a paper clip.



Preamplifier in operation with a crystal microphone is shown here connected to a high fidelity 10-watt phono amplifier designed for crystal pickups only.

Dual Purpose PREAMPLIFIER

THIS preamplifier with its novel self-contained power supply is designed for use with either a crystal microphone as a high gain voltage amplifier or one of the new type magnetic pickups (G. E., Pickering, etc.) which require an equalized preamplifier. The DPST (double pole, single throw) slide switch changes the preamplifier circuit for use with a mike or magnetic cartridge. Cost of construction is from eight to 10 dollars.

The power supply uses two small 6.3 volt, 1 ampere filament transformers to supply plate voltage and 6.3 volts for the tube and pilot light. The first transformer steps down line voltage to 6.3 volts for the tube filament and pilot bulb. The second filament transformer is used backwards with its secondary connected in parallel with secondary of first transformer. Voltage is stepped back up to 110 volts in the second transformer and fed into the half wave selenium rectifier circuit, where it is rectified and filtered to provide plate voltage for the preamplifier. This transformer arrangement isolates the 110 volt power line from the chassis and all the entire preamplifier circuit. The chassis is safe to handle and hum is kept at a minimum since the chassis may be kept at a ground potential.

The output of the new type magnetic pickups is low and requires amplification before it can be fed into a phono amplifier or the phono input

You can use either crystal mike or magnetic cartridge with this selfpowered combination preamplifier

By MILO ADLER

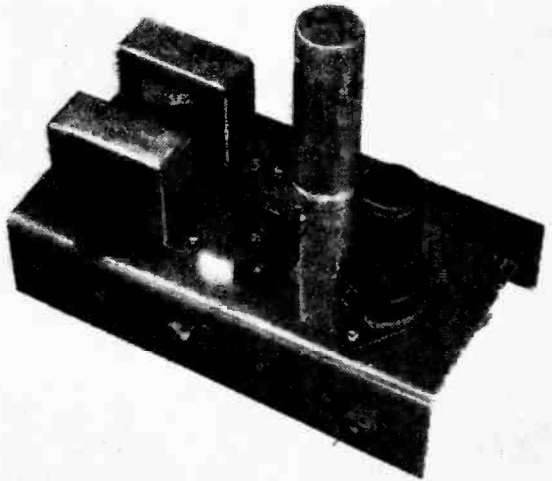

Closeup of preamplifier unit.

terminals found on many radios. Output of the cartridge is higher for high frequency audio notes than low frequency or bass notes. The equalized preamplifier boosts bass notes and at

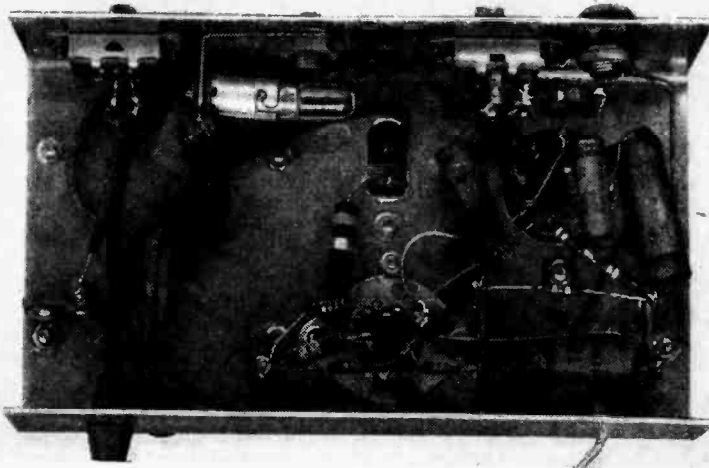

Underneath of preamplifier showing parts.

the same time raises output voltage until it is equivalent to the voltage obtained from the conventional crystal cartridges.

The new type magnetic pickups are designed to operate into a load of 5000 to 10,000 ohms. The value of this resistor should be varied depending upon the actual cartridge used. This resistor is shown as having a 6,800 ohm value in the schematic diagram. This is the correct value for a G. E. variable reluctance cartridge. In the event another type of magnetic pickup cartridge is used this resistor should be changed so that it will have the value recommended by the cartridge manufacturer.

When the preamplifier is used with a crystal mike it is only necessary to amplify the extremely small voltage from the microphone. The equalizing network is not necessary and if used, too much bass shows up in output of preamplifier. The equalizer circuit may be switched out for use with a mike by turning equalizer on-off switch to off position. At the same time, the 6,800 ohm resistor is switched out of the circuit as it is much too small in value for a crystal mike load resistor.

The gain of the preamplifier is greatly increased when the

equalizer is switched off. For this reason care should be taken when constructing preamplifier to be sure that all wires are as short and direct as possible in order to prevent oscillation within the preamplifier. The preamplifier will oscillate when microphone is disconnected from input jack.

To construct the preamplifier, first punch and form the chassis from sheet aluminum or steel. (Aluminum is easier to work—and looks

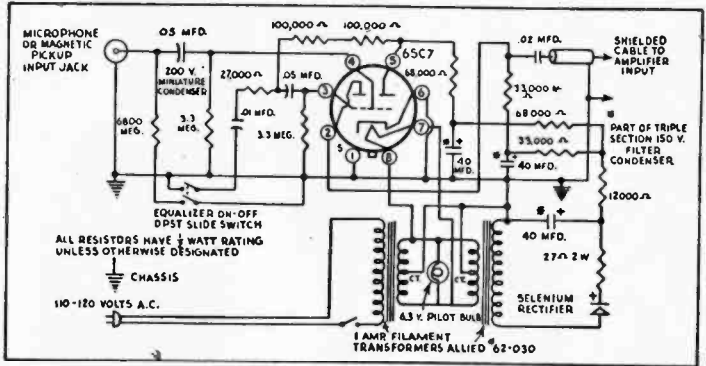

MATERIALS LIST—PREAMPLIFIER

- 1 7" x 4" x 1½" chassis (sheet aluminum or steel)
 - 1 Octal socket (Amphenol type 78RS8)
 - 1 50 or 65 ma. selenium rectifier
 - 1 65C7 tube
 - 1 40-40-40 mfd., 150 volt filter condenser (Mallory type FP357)
 - 1 .05 mfd., 200 volt miniature paper condenser (Sprague 68P16)
 - 1 .05 mfd., 400 volt paper condenser
 - 1 .02 mfd., 400 volt paper condenser
 - 1 .01 mfd., 400 volt paper condenser
 - 1 27 ohm, 2 watt resistor
 - 1 6800 ohm resistor*
 - 1 27,000 ohm resistor
 - 2 33,000 ohm resistors
 - 2 68,000 ohm resistors
 - 2 100,000 ohm resistors
 - 1 120,000 ohm resistor
 - 2 3.3 megohm resistors
 - 1 Mike connector (Amphenol type 75-PC1M or equivalent)
 - 1 DPST Slide Switch (Allied 34-492)
 - 1 SPST Slide Switch (Allied 34-490)
 - 1 Amber pilot assembly with bayonet socket
 - 1 6.3 volt pilot bulb (type 47)
 - 2 Double insulated tie lugs
 - 2 Single insulated tie lugs
 - 2 6.3 volt, 1 amp., center tapped filament trans. (Allied 62-030)
 - 1 Line cord and plug
 - 6 ft. Shielded wire
 - 4 Small rubber grommets for mounting socket (Require ¼" mounting hole)
 - 4 Rubber grommets to fit 7/16" mounting holes
 - Misc.: Hook-up wire and solder and hardware
- * Note: High frequency response may be increased by increasing value of this resistor up to as high as 15,000 ohms.

finished). If parts specified in materials list are used, punch chassis as shown in diagram and parts will fit without any modifications. Arrow in chassis diagram indicates direction of locating notch in tube socket; this positions tube so that pins No. 1 and No. 8 face toward chassis front.

Large mounting ears in Amphenol type 78RS8 tube socket have a slot for mounting bolt instead of conventional single round hole. Ream out outer end of these slots so that a rubber grommet with inside diameter of $\frac{1}{8}$ in. may be inserted in enlarged hole. Also ream mounting

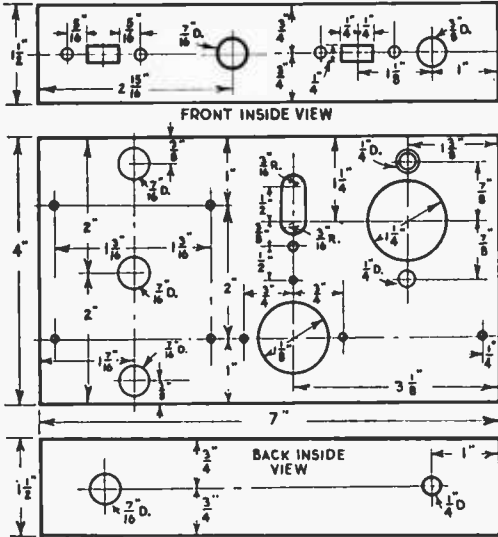

holes in chassis for same size grommet. Mount socket with two $\frac{5}{32} \times \frac{1}{2}$ in. rh (roundhead) machine screws passed through the grommets. Place flat steel washer over end of machine screw and then tighten nut just enough to hold socket in place while allowing socket to have a floating mounting. Make sure floating movement of socket is not impaired when wiring to the socket. Apply quick drying radio or model builders' cement to nut to help hold it in place. Mounting the tube socket this way eliminates microphonics due to mechanical feedback.

Mount the tiny 50 or 65 ma. (milliampere) selenium rectifier on top of the chassis with a small bracket and a $\frac{5}{32} \times \frac{3}{4}$ in. rh machine screw. When connecting this rectifier, be sure to observe the polarity shown in the schematic diagram. Positive side of rectifier is marked with a small plus sign. Connect all grounded points together with a wire to reduce hum.

Select an input connector which fits connector on mike to be used. Omit pilot light if pre-amplifier is mounted where this light will not be seen. Use shielded microphone cable to connect a mike to preamplifier and shielded wire to connect magnetic pickup, and when feeding pre-amplifier output to phono amplifier input.

GET THE WORLD'S LEADING RADIO & TV CATALOG

FREE
 236 PAGE
 VALUE-PACKED
1953
ALLIED
 BUYING GUIDE

Experimenters and Builders:
Save on Everything in Radio & TV!

You'll find everything you'll need for building any project in this handbook in the 1953 ALLIED Catalog. Select from the world's largest stocks of parts, tubes, tools, kits, books, diagrams—plus Amateur equipment, TV components, Hi-Fi equipment, test instruments, recorders—at lowest, money-saving prices. Write for your **FREE ALLIED Catalog today!**

POPULAR ALLIED KITS

Famous Radio Lab Kit (10 Kits in 1)

Here's the most instructive Experimenter's kit you can buy. With it, you can build a broadcast receiver, phono amplifier, phono oscillator, signal tracer, electronic timer, photo cell relay, home broadcaster, electronic switch, etc. Fascinating, instructive. Complete with all parts, tubes, microphone. 12-page manual. Shpg. wt., 10 lbs. **83-285. Radio Lab Kit, only...\$14.25**

Popular "Ocean Hopper" (Amazing DX)

A remarkable Short-Wave receiver. Covers 9.5-550 meters (550 kc-31.5 mc) with plug-in coils. Features bandspread; for head-phone or speaker use. Easy to build. Complete with all parts, tubes, 2 coils for broadcast band, hardware, full instructions. For AC-DC Shpg. wt., 5 lbs. **83-225. "Ocean Hopper" Kit, only \$18.75**
60-660. Four SW coils (9.5-217 meters).....\$2.45
59-110. 2000 ohm headset.....\$1.50

Ranger Superhet (with Cabinet)

Learn radio while you build and enjoy this sensitive AC-DC broadcast receiver. Tunes 535-1620 kc; includes built-in antenna. 5" PM dynamic speaker, automatic volume control, handsome walnut plastic cabinet. Easy to assemble from detailed manual; complete with punched chassis, all parts, tubes and cabinet. Shpg. wt., 8 lbs. **83-275. "Ranger" Kit, only.....\$17.85**

DOZENS OF OTHER KITS AVAILABLE

ALLIED RADIO CORP.

ALLIED RADIO CORP. Dept. 64-K-2
 833 W. Jackson Blvd., Chicago 7, ILL.

- Send FREE 236-Page Catalog
- Send Kit No. 83-265 \$.....
- Send Kit No. 83-225 } enclosed
- Send Kit No. 83-275 } prices FOB Chicago

Name.....

Address.....

City.....Zone.....State.....

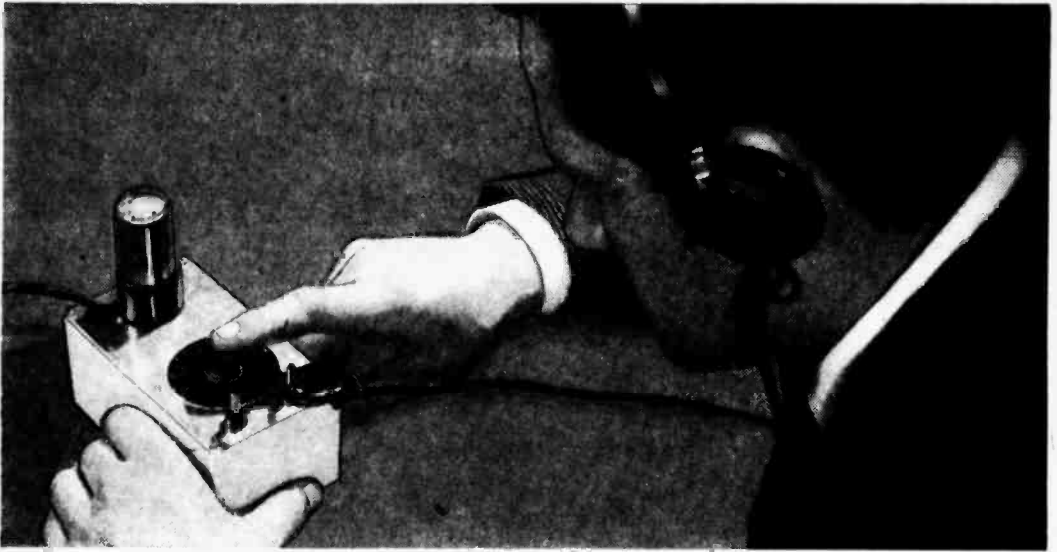

One Tube Electronic Metronome

THE metronome is familiar to anyone who ever took a music lesson. The pyramid-shaped wooden box with its clock-spring works contains a pendulum which, as its swing is varied by adjustment of lever or knob, provides a suitable tempo for the student to follow. This electronic metronome produces the same type of beats without benefit of clockworks or other moving parts. The simple multi-vibrator-type circuit consists of 2 interlocked oscillators whose grids are made positive by a .1 mfd. paper capacitor which obtains its charge from the plate circuit. The grid leak bias to ground in one oscillator is fixed. In the other, the rate of discharge is variable through a 10 megohm potentiometer. As one circuit charges the other discharges; the rapidity of this action depending upon the setting of the potentiometer.

When used as a metronome proper, the student can plug in a pair of headphones, or, for room volume, connect metronome to phono jack of a radio, TV or audio amplifier set, using a length of mike cable with phone tips on one end and phono plug on the other.

Although this electronic device contains no moving parts, it beats out the rhythm you want just like a mechanical metronome

By THOMAS A. BLANCHARD

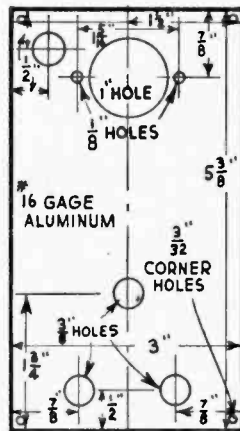

RECTIFIER BRACKET

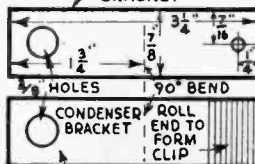

TIN, OR ANY LIGHT METAL

1 PANEL LAYOUT FOR METRONOME

MATERIALS LIST—METRONOME

- 1 aluminum panel, 5 $\frac{3}{8}$ " x 3"; #16 gage
- 1 octal water socket with 1 $\frac{1}{16}$ " mounting centers
- 2 100K (100,000 ohms) 1/2 watt carbon resistors
- 1 560K (560,000 ohms) 1/2 watt carbon resistors
- 1 24K (24,000 ohms) 1/2 watt carbon resistors
- 1 1K (1,000 ohms) 1/2 watt carbon resistors
- 1 47 or 50 ohms 1/2 watt carbon resistors
- 1 10 meg. potentiometer (IRC #D11-143)
- 1 line sw. for above (IRC #41)
- 1 line cord resistor 290-350 ohms (see text)
- 1 20-20 mfd., 150 v. electrolytic condenser (paper tube type)
- 2 .1 mfd., 150 or 200 v. paper capacitors
- 2 .01 mfd. 150 v. paper capacitors
- 1 65 or 100 ma. selenium rectifier (Federal, Selenon, etc.)
- 2 insulated phone tip jacks
- 1 type 12SN7GT dual-triode tube
- Miscellaneous: hook-up wire, dial plate (optional), 2 #4-40 x 3 $\frac{1}{8}$ " rh screws and nuts, 4 small rh wood screws, and bar knob.

If device hums excessively, reverse phone tips on metronome jacks.

From an industrial viewpoint, this electronic metronome could, for example, be used to adjust clocks on a factory production line, provided there were no substantial line voltage fluctuation. First a specimen clock would

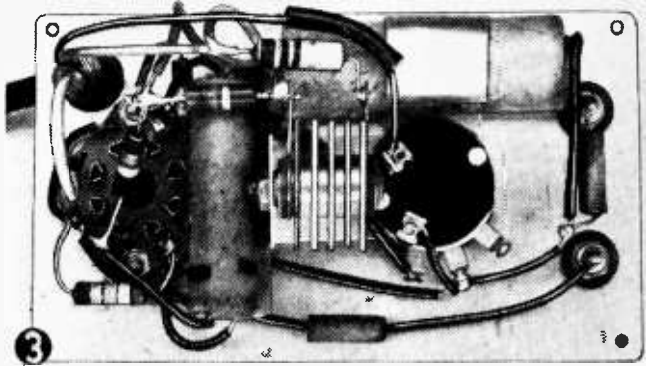
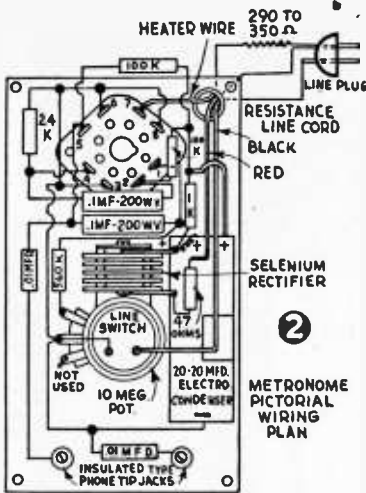

Above is an underneath view of the metronome showing parts wired in place. Check this against Fig. 2 for clarification.

be adjusted and given a shelf test for accuracy. The electronic metronome, connected to a constant voltage power line, would be "tuned" until its beat corresponded to the tick of the clock. Thereafter, clocks on the production line would be adjusted so their click was synchronized with "standard" beat heard in metronome phones.

To use metronome with signal or alarm devices, connect sensitive type relay with a coil resistance between 2,000 and 5,000 ohms to Lug #5 and #8 of the 12SN7GT tube (thus bypassing the two .01 mfd. capacitors in the output). Wire relay contacts in series with a signal light, horn, bell or siren. The frequency of signal's sounding is adjustable by turning potentiometer knob.

You can alter the dimensions of this metronome as desired or even build it in a cigar box if you wish! The plastic case shown here measures 3 in. wide x 5/8 in. long x 2 1/4 in. deep. Since there was no provision for panel mounting screws, 4 short lengths of 1/4-round molding were cemented into box corners with Duco cement. Wood screws secure aluminum panel and components.

Cut metronome panel from #16 soft aluminum and provide with holes as shown. Form 2 metal brackets from #20 aluminum, copper or tin-can steel, support selenium rectifier and electrolytic condenser. These brackets require no special mounting provisions since both are slipped on potentiometer bushing and made rigid to panel upon tightening of potentiometer nut.

Inasmuch as the 12SN7GT dual-triode tube must obtain its heater supply from 115 volt ac-dc power line, a voltage-drop resistor, ballast tube or line cord resistor is required. For compactness, the latter was chosen. However, where metronome is constructed in larger quarters; either ballast or 50-watt wire-wound resistor of approximately 290-350 ohms may be used. The capacitors in the circuit need not be rated at more than 150 volts. Units rated at 400 or 600 volts may be used, but they occupy more space.

The line cord resistor is shown in the pictorial

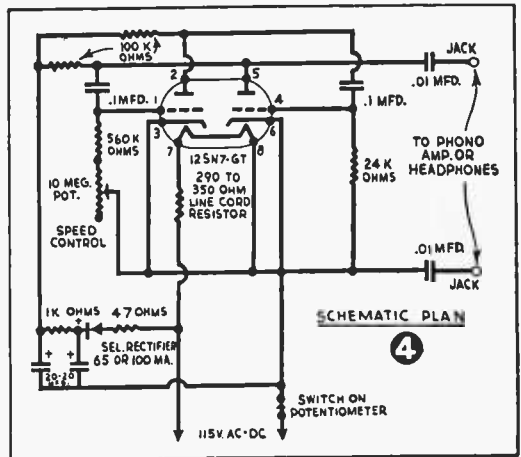

wiring diagram in semi-schematic form for clarification. In most cases, the black and red wires connect directly to the plug attached to the cord (like any fixture cord). But interwoven with the black and red leads, there is an asbestos cord carrying the heater resistance wire (usually white, gray or brown), which is connected to prong #7 of tube socket. Check cord connections carefully before turning on unit the first time, since a reversed connection will burn out a tube. In operation the fixture cord will become warm, but this is normal, and nothing to cause alarm. Never cut off or shorten this cord—or you will lower its resistance and burn out tube. Line cord resistor value depends upon line voltage furnished in your area. To determine correct ohm rating for cord, subtract 12 volts from your line voltage and divide the result by .3. Example: Line voltage is 115 volts; subtracting 12 leaves 103. Dividing .3 into 103 you get 343 ohms. Purchase cord which has nearest higher value, which is one rated 350 ohms.

Wire the metronome according to pictorial plan. Use 50-50 or not less than 64-40 rosin core radio solder, making good, firm connections.

Versatile Oscillator

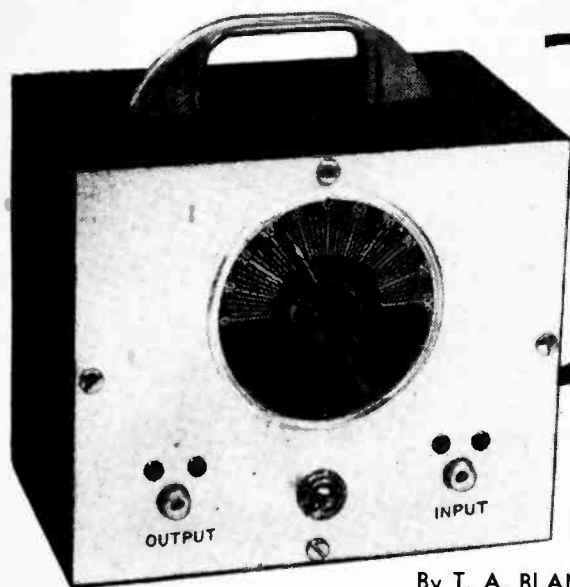

By T. A. BLANCHARD

This compact oscillator plays records by wireless and generates signals for aligning superhet receivers

THIS compact oscillator performs double duty as an efficient wireless record player and signal generator. Employing a miniature 35W4 rectifier and a miniature 12BA6 pentode in a grid-modulated Hartley-type oscillator circuit, the trim assembly shown in Fig. 1 measures only 6 x 5 x 4 inches. A signal generator is a most useful tool when aligning a superheterodyne type receiver that is "out of whack."

The oscillator is built into a standard metal radio utility box (sold by all radio parts suppliers). These boxes are available in a variety of sizes—in black wrinkle steel or hammertone aluminum, which is a bit more expensive than steel. A plastic drawer pull from the dime store provides a neat carrying handle. To get started building the oscillator cut the chassis from 16 or 18-gage aluminum and cut the necessary component mounting holes as shown in Fig. 3. Bend down a $\frac{7}{16}$ in., 90° fold along the front edge of the chassis for attaching to the front panel of the cabinet. The same screws which secure the chassis to cabinet also fasten the *input* and *output* jacks to the front panel. Instead of using two of the single round phono jacks, a double rectangular phono jack strip was cut in half. If you use the round single jacks, however, separate mounting holes and screws will be required. When purchasing the jacks, order a pair

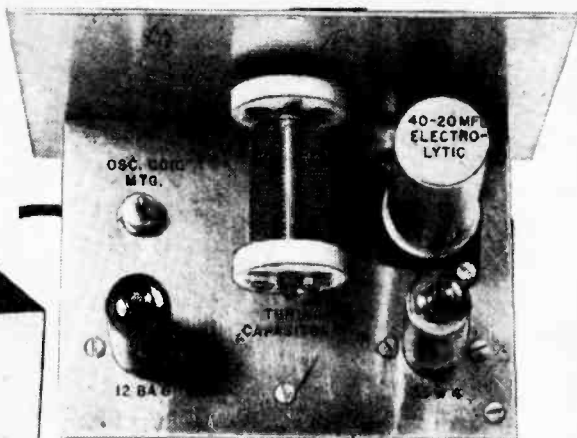

2 Fig. 2. Chassis provides ample room for using standard-size single-gang capacitor instead of the more costly miniature type shown above.

Fig. 1. Trim oscillator is both wireless broadcaster and test instrument for aligning.



of phono tip plugs at the same time to match the jacks. One phono plug connects to the phono pickup at the oscillator. The other tip is used for a shielded or unshielded output wire from the oscillator for testing and

aligning. Arrange the components on chassis as shown in Fig. 2 and pictorial wiring plan (Fig. 5). A can-type dual-electrolytic capacitor with a 40 and 20 *mfd.*, 150 *w. v.* rating mounts over the $1\frac{1}{8}$ -in. dia. hole. The electrolytic capacitor should be of the *insulated* type. This unit resembles any other can-type electrolytic capacitor, except that it includes a black paper tube which insulates the can, plus a Bakelite mounting plate instead of the usual metal plate. Fig. 2 shows the capacitor with paper tube removed. The tube is not essential, but the Bakelite mounting plate is required to insure a shockless isolated ground circuit.

The oscillator coil is a regular Hartley tapped type, the same kind used in small portable superheterodyne receivers. Two suitable types are indicated in the Materials List. Sometimes the Hartley coil is cataloged simply as 6SA7 or 12SA7 type. Oscillator coils are built with either a metal bracket for mounting with screws and nuts or a snap-in fastener. After mounting tube sockets and a 2-lug terminal strip, you may begin wiring the oscillator following the pictorial wiring plan. (Fig. 5).

When using the oscillator as a home broadcaster, the maximum capacity of the tuning capacitor need not be over 250 *mmf.* This will tune from about 1700 *kc.* to 1000 *kc.* approxi-

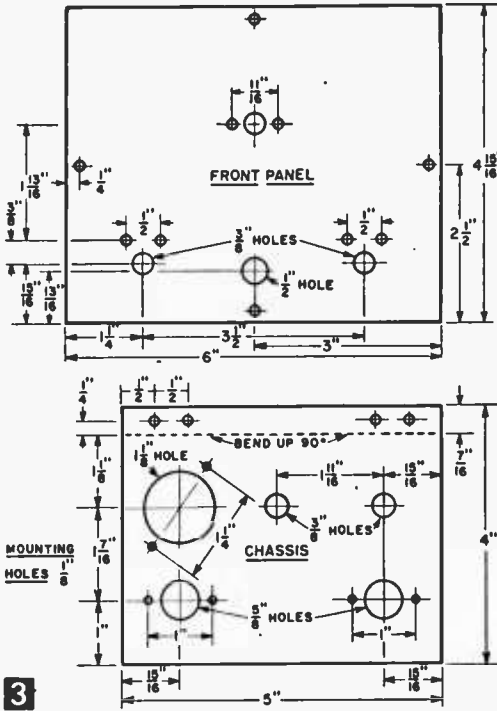

3

mately. However, greater range is required when using the device as a signal generator. Therefore, a fixed mica capacitor of 470 mmf. is shunted across the variable capacitor to tune beyond 550 kc. (see schematic plan, Fig. 4.)

You can replace the miniature tuning capacitor with 410 or 450 mmf. maximum capacitance. The standard size capacitors cost much less than the miniature units, and there is ample room on the chassis for the larger sizes. You will still have to use a fixed capacitor with the larger tuning capacitor when tuning beyond 550 kc., however.

Since the oscillator employs no step-down transformer, a voltage-dropping resistor is wired in series with the tube heaters. Mount this 470 or 500-ohm, 25-watt unit near rear of chassis and away from other components, as shown in Fig. 6.

PHONO OSCILLATOR. (Wireless record player). Solder inner wire of shielded phonograph pickup wire to center pin of jack plug. Solder shield braid to the outer shell of phono plug. Insert this lead from the phonograph into the input jack of

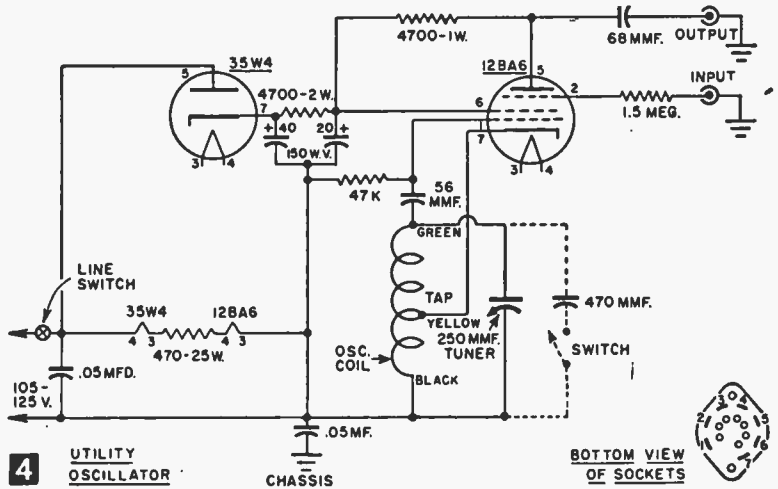

4 UTILITY OSCILLATOR

BOTTOM VIEW OF SOCKETS

MATERIALS LIST—OSCILLATOR

- 1 metal radio utility cabinet, 4 x 5 x 6". (ICA #3812, or #29812)
 - 1 aluminum chassis, 5 x 4"
 - 1 hartley-type oscillator coil. (Stanwyck #201, Meissner #14-1033)
 - 1 can-type electrolytic capacitor, insulated type. 40-20 mfd., 150 v. (Sprague, Mallory, C-D, Aerovox.)
 - 1 Single Gang Tuning Condenser. (250,410 or 450 mmf. The 410 mmf. size is suggested.)
 - 2 7-pin miniature wafer sockets
 - 2 phono jacks and plugs to match
 - 1 toggle switch 1 slide switch (both s.p.s.t. type)
 - 1 6-ft. line cord and plug
 - 1 2-lug terminal strip
- Fixed Capacitors**
- 1 68 mmf. mica or ceramic capacitor
 - 1 56 mmf. mica or ceramic capacitor
 - 1 470 mmf. mica or ceramic capacitor
 - 2 .05 mfd. molded paper capacitors
- Fixed Resistors**
- 1 470 or 500 ohm, 25-watt wire wound resistor
 - 1 4700 ohm, 2-watt carbon resistor
 - 1 4700 ohm, 1-watt carbon resistor
 - 1 47K (47,000) 1/2-watt carbon resistor
 - 1 1/2 megohm, 1/2-watt carbon resistor

oscillator. To make up a broadcasting antenna, solder several feet of ordinary insulated hook-up wire to the center pin of the remaining phono plug. Leave the outer shell unconnected. Plug this flexible lead into the output jack of the oscillator to broadcast from the oscillator. Turn on your radio and the oscillator and allow both to warm up about 30 seconds. Tune the radio between 1600 and 1300 kc. where no regular station comes in and slowly tune the oscillator until a strong purring signal is heard from the radio.

Another method of tuning oscillator to radio is to simply start a record on the turntable and tune oscillator until the recorded music comes from the radio. When tuning the oscillator, you will hear a signal at several points on the dial. However, there will be only one point where the signal is heard clearly and without heterodyne whistles in the background. Therefore, when tuning the oscillator, be sure your set is receiving the fundamental signal being transmitted and not one of the harmonics.

SIGNAL GENERATOR. When using the oscillator as a signal generator, you will first have to locate three frequency settings on the oscillator, as accurately as possible. You may be able to use a professional signal generator from your local school against which your homemade oscillator may be calibrated. Tune the professional signal generator first to 1700 kc. and feed the signal from the output plug, through a shielded wire, to antenna post of a radio set. After tuning the radio to receive the professional generator's 1700 kc. signal, disconnect the generator. Be careful not to change the radio's dial setting during this operation. Now attach the output cable of your oscillator to the radio's antenna post, and tune the oscillator until the radio picks up its fundamental signal. Mark this 1700 kc. dial setting for future reference, on your oscillator.

Repeat this calibrating procedure with the professional signal generator next tuned to 1500 kc. and again at 455 kc. Your homemade oscillator will now have three precise frequency adjustments. The fourth setting is obtained by connecting 470 mmf. fixed capacitor across the oscillator's tuning capacitor.

If you don't have access to a professional signal generator, you can calibrate the oscillator with a good radio set. First, tune the radio so variable capacitor plates are wide open. The radio will then be tuned approximately at 1700 kc. Attach inner output lead of oscillator to antenna post of radio and tune oscillator until its carrier signal comes in over the radio. Mark oscillator dial at the precisely tuned point as 1700 kc. Now tune radio beyond 550 on its dial so capacitor plates are fully meshed. This is approximately 455 kc. but it's best to check this setting against a professional signal generator for calibrating the 455 kc. setting. Switch-in the 470 mmf. fixed condenser and tune the oscillator until signal is again heard through the radio. Mark this setting on oscillator dial as 455 kc.

Finally, to obtain the 1500 kc. setting, disengage the 470 mmf. fixed capacitor across tuning capacitor and tune radio dial to 1500 kc. Tune the oscillator until its carrier signal is heard through the radio, and mark this setting on the

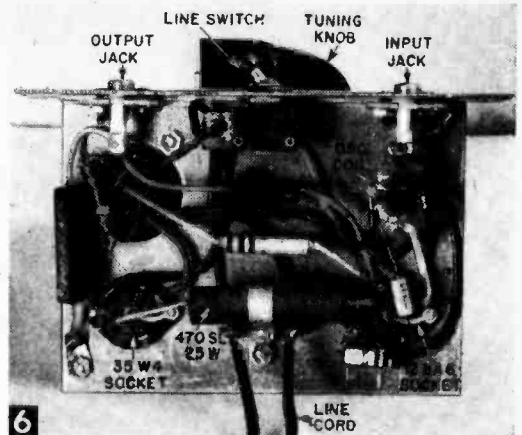

Fig. 6. Bottom view of oscillator. Although compact, there is plenty of room for components.

dial as 1500 kc. The 1500 kc. setting can be fairly accurately located since there are nearly 150 stations in U.S., Canada, and Alaska operating on 1490 kc. By tuning your radio just above one of these 1490 kc. broadcasters—just enough so their signal is not heard, the set will be very close to 1500 kc. The 1500 kc. setting may also be located in many parts of the country by tuning in either WTOP in Washington, D. C. or KSTP in St. Paul. Both of these stations operate on 50,000 watts, 1500 kc. and may be received in many parts of U.S. and Canada at night.

ALIGNMENT FOR 455/465 KC. I.F. SUPERHETS. One of the most troublesome problems in radio servicing is the alignment of the I.F. sections of a receiver for peak performance. To use the oscillator for this job, insert the shielded lead into output jack on oscillator. Connect the inner cable wire to the stator plates of R.F. section of tuning condenser (section with the large plates). Then ground the shielded braid of cable to the radio set chassis. Tune oscillator to 456 kc.

Tune the radio so variable capacitor plates are fully closed, and turn up volume control. Now, with a plastic blade screwdriver, made by filing a knitting needle to a screwdriver edge, adjust the screws on the second I.F. transformer until the "purring" carrier signal of the oscillator comes through at peak volume. Since this volume may be considerable, retard the volume control so carrier signal comes in distinctly.

With the plastic blade screwdriver, adjust the screws of the first I.F. transformer to again raise the volume of the carrier's "purr." The I.F. transformers can be given a final polishing off, by a final adjustment of the second I.F. and another adjustment of first I.F. screws.

The final adjustments of aligning the radio set are for tracking the gang tuning capacitor. Connect the inner wire of the shielded output cable from the oscillator to the antenna post of the radio. If the radio has no antenna connection, place a plain unshielded wire from the output jack of oscillator near the radio's antenna loop,

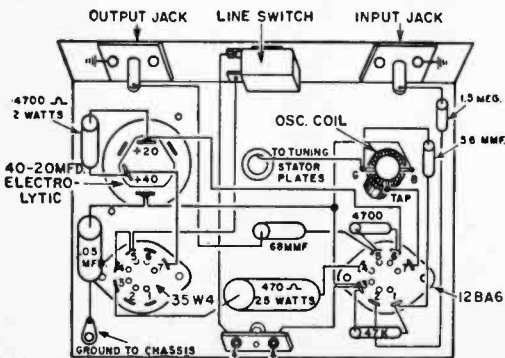

UTILITY OSCILLATOR - LAYOUT FROM BOTTOM

or tape the output wire to the radio's loop for adequate capacitance pick-up. No actual connection need be made to the loop.

Tune both the oscillator and radio dial at 1700 kc. Now adjust the small trimmer capacitor below the oscillator section small plates of tuning capacitor with plastic blade screwdriver until

oscillator signal is loudest. Finally, tune oscillator and radio to 1500 kc. and adjust the small trimmer below the R.F. section large plates of tuning capacitor for maximum volume with the plastic blade screwdriver. With these adjustments for peaking performance, your receiver alignment is finished!

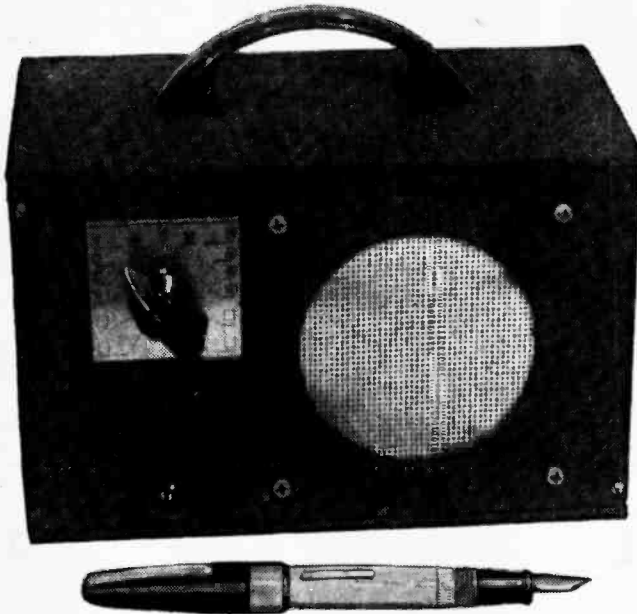

Super-Midget measures only $7\frac{1}{4}$ x $4\frac{5}{8}$ x 4 in. Simple homemade wooden cabinet, felt-flocked, and plastic carrying handle give it a professional appearance.

out panel according to diagram, and punch and drill holes as shown. When completed, bend chassis in a vise along dotted lines.

If you do not have suitable hole punches in order to make $\frac{5}{8}$ in. and $\frac{3}{8}$ in. holes required for tuning condenser, volume control and sockets, drill with a hand or electric drill, then enlarge to correct size with a pipe reamer fitted in a hand drill (or bit) brace. Because aluminum is soft, these holes take but a minute to make with a reamer.

Do not make chassis until all parts are on hand. Mounting holes of some components may vary from the original. Therefore, all large holes can be cut, but $\frac{1}{8}$ in. mounting holes should be checked with the particular parts you receive from your radio supplier.

Super-Midget Portable

This tiny set works anywhere on self-contained batteries and built-in loop antenna

By THOMAS A. BLANCHARD

THIS miniature portable superhetrodyne radio, operating on self-contained batteries and provided with built-in loop antenna, packs an amazing amount of power. The circuit may appear somewhat complex to the novice. However, after making up the chassis and mounting the various components, the actual wiring is not complicated. Mark the schematic diagram with a colored pencil as each wire, resistor, or condenser is connected into the circuit.

This 4-tube superhet is designed on a simple aluminum chassis formed from a piece of #18 or #20 gage aluminum measuring 5 x 4 in. Lay

The professional looking cabinet is actually a humble, homemade affair. The neat, velvet finish is flock applied to rough wood construction. The top, bottom, and sides of original cabinet were cut from wood salvaged from a melon crate. Front and rear panels were $\frac{1}{8}$ in. Masonite, but the thin crate pine would have served equally well. Cut cabinet pieces to dimensions shown in photogram. Nail and glue top and bottom pieces to $\frac{7}{16}$ in. thick side pieces. (At the mill, ask for $\frac{1}{2}$ in. pine which is actually $\frac{7}{16}$ in. thick when planed.) Top and bottom pieces extend out $\frac{1}{8}$ in. on each side, so that when front and back pieces are attached, the members are all flush.

Loop is attached to inside of back with a single 6-32 nut and bolt. Ample room behind B battery is provided for A batteries (standard flashlight cells).

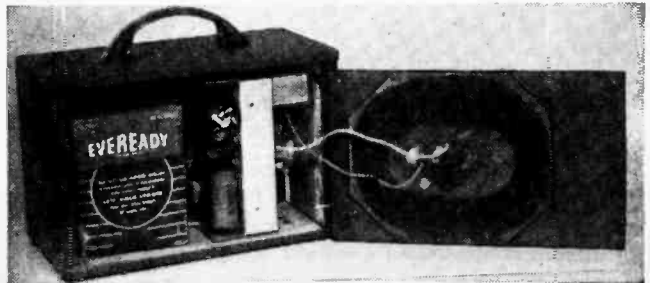

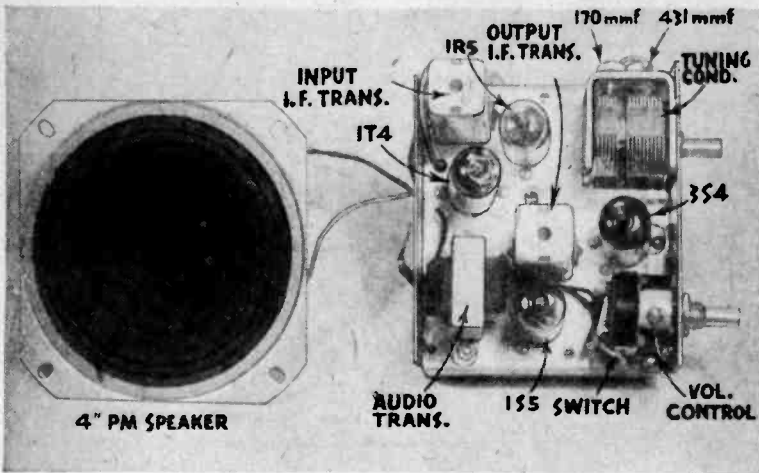

Chassis and speaker before mounting in cabinet. Mounting positions of parts are clearly indicated.

over all surfaces. Allow 12 hours for drying, then brush off loose flock, leaving a fine velvet finish.

The 4-in. PM speaker and radio chassis are now ready for mounting on front panel. Secure chassis by threaded volume control bushing which is sufficiently long to pass through chassis mounting hole and Masonite panel. Slip a 3/8 in. washer over volume control bushing before panel is attached so as to allow clearance for the two 6-32 binding head screws holding tuning condenser. Secure complete radio chassis to panel by volume control nut—no separate mounting screws are necessary. The tuning dial plate is available from radio suppliers in both numerical 0-100 calibrations. Attach plate to panel with brass nails provided for the purpose. Clip off excess nail projecting behind panel.

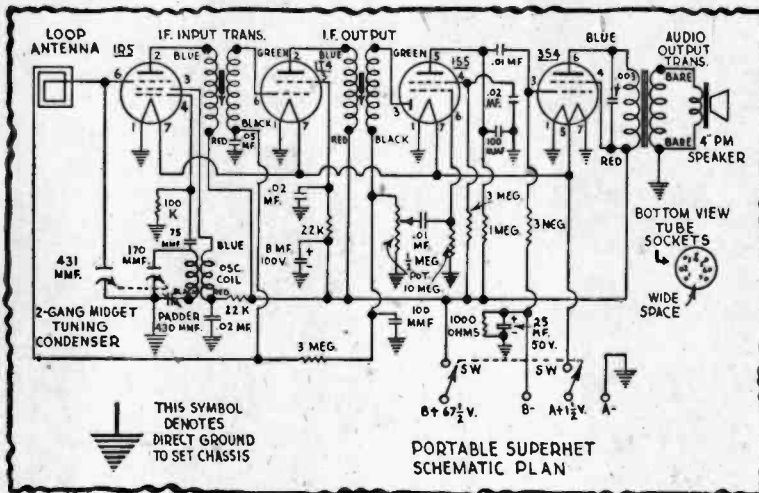

The rear cabinet panel is a plain piece of 4 1/4 x 7 3/8 in. Masonite. Drill front panel for tuning condenser shaft, and volume control. Cut a 3 in. diam. hole for PM loudspeaker with a "fly-cutter" with blade reversed so as to provide a beveled edge. A plain hole can be cut with an ordinary hand coping or jig saw of dime store variety or a Dremel Moto-Saw. After cabinet sections have been completed, apply a heavy coat of quick drying enamel to each member. While paint is wet, shake a heavy coating of felt flock (sold by art and radio supply houses)

may be made or purchased. If homemade, wind with Litz coil wire or #24 double cotton covered magnet wire. To make loop antenna, first cut a piece of stiff cardboard 4 x 5 in. Now, in clockwise direction, wind an oval shaped turn as near

Bottom of chassis showing condensers, sockets, and resistors. Oscillator coil is mounted under chassis in position shown to prevent feedback (howling).

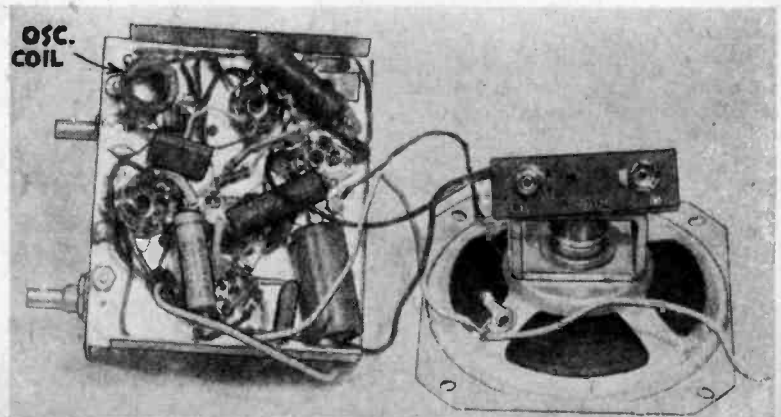

to outside edges of cardboard as possible. Anchor this first turn with Duco cement, Ambroid, nail polish, or other acetate adhesive. Give the first turn sufficient time to dry, then continue to wind, inward from first oval turn, additional turns until a total of 50 have been made. Apply cement as each turn is completed so finished loop coil is firmly attached to cardboard.

Pierce two holes in center of cardboard with an icpick so flexible insulated leads may be attached to loop antenna. Insert ordinary dress snap fasteners, and solder ends of coil to them. Fasten flexible connecting leads to set in same manner. Be sure to remove enamel insulation from Litz before attempting to make a soldered connection. Attach loop coil to rear cabinet panel with a spring type binding post which also serves as outdoor antenna connection where greater range is desired. If the outside antenna is used, insert a .005 mfd (5000 mmf.) mica condenser between binding post and Pin #6 of 1R5 tube socket.

Unlike the majority of midget portables, this set employs a full 4-in. PM speaker for much better tone quality and volume than is obtained from smaller size speakers. Attach speaker to front panel with 4 rosette or fillister head machine screws, 3/8 in. long. To protect speaker cone, insert a grille made of plastic or aluminum fly screening in between speaker and panel. If available, use perforated aluminum as in original model.

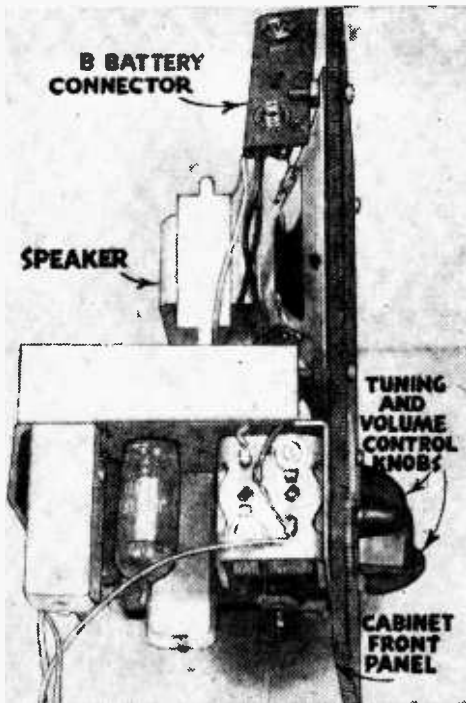
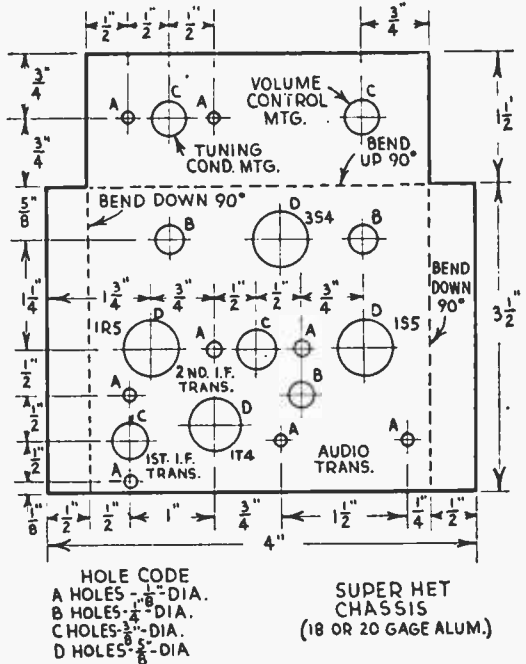

Chassis attaches to front panel with volume control nut. Four 6-32 screws secure PM speaker. The resulting one-piece assembly can be easily removed from case for servicing.

MATERIALS LIST—SUPER-MIDGET PORTABLE

- 1 midget 2-gang Superhet tuning condenser (approx.)
- 1 trimmer or padder condenser (430 to 500 mmf. max.)
- 1 1/2 megohm (0.5 mg.) volume control with double pole single throw switch
- 1 midget output transformer (354 type) 5000-ohm plate to 4-ohm voice coil
- 1 4" PM speaker
- 4 7-pin Amphenol molded miniature sockets
- 1 midget loop antenna
- 1 oscillator coil, 455KC
- 1 455 kc input I.F. transformer, Stanwyck type SM 1075
- 1 455 kc output I.F. transformer, Stanwyck type SM 1075

FIXED RESISTORS (all 1/4 or 1/2 watt)

- 3 3 or 3.3 megohm
- 1 10 megohm
- 1 1 megohm
- 1 100K (100,000) ohms
- 2 22K (22,000) ohms
- 1 1000 ohms

FIXED CONDENSERS (Capacitors)

- 1 75 mmf. mica condenser
- 2 100 mmf. mica condenser
- 1 .003 mfd. mica or paper condenser
- 3 .02 mfd. paper condenser
- 2 .01 mfd. paper condenser
- 1 8 mfd. electrolytic condenser (100 w.v.)
- 1 25 mfd. electrolytic condenser (50 w.v.)
- 1 .05 mfd. paper condenser
- 1 5000 mmf. (.005 mfd.) mica or paper condenser. (Required only if external antenna connection is used)

MISCELLANEOUS

- 1 1R5 tube
- 1 1T4 tube
- 1 1S5 tube
- 1 354 tube
- 1 67 1/2 v. B battery
- 2 1 1/2 v. flash cells
- 1 dial plate & knobs
- Hook-up wire, screws, as indicated.

Front, back, top and bottom pieces may be $\frac{3}{8}$ in. pine or Masonite. Finished velvet-like surface is achieved with felt flock.

The set is powered by a 67½ volt miniature B battery which is good for several months heavy use. The tube filaments obtain their 1½ volts from ordinary standard size flashlight batteries. A single cell may be used, but for longer A-battery life, use two connected in parallel. **WARNING:** Do not accidentally hook them in series or all tubes will burn out immediately!

The brass cap of a flashlight battery is *plus*. The zinc case is *minus*. Connect two brass caps together and two cases together for parallel operation. Polarity is printed on B battery case.

When correctly wired, the set should work without adjustment of any components except for "padder" or "trimmer" condenser in oscillator

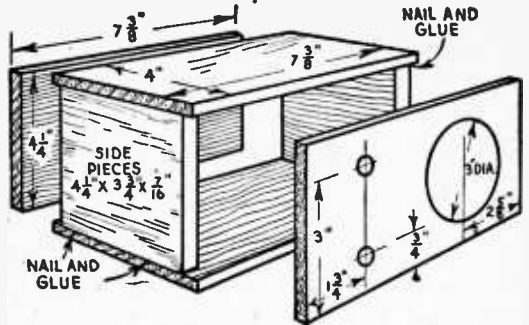

coil circuit. Usually parts are factory adjusted and need no further attention. In those rare instances where complications arise, have a radio serviceman align finished set.

Improving Loudspeaker Performance

A LOUDSPEAKER cone radiates high frequency notes from the center of the cone in a narrow beam, while low frequencies are radiated from entire surface of cone at a very wide angle (Fig. 1). This is true even with better quality speakers of the single cone type, making it almost necessary to sit in front of the speaker to enjoy the highs in the best phono records or in an FM broadcast, particularly with amplifiers which have a good high frequency response.

You can improve loudspeaker performance by mounting a 10-cent plastic funnel in center of speaker cone (see photos). Funnel spreads highs by allowing part to pass through center of funnel, while funnel sides force remainder out at an angle so they can be heard better all over the room (Fig. 2). The better quality single cone speakers, such as the Jensen P12-SX (pre-war model number PM12-CT), and the General Electric S-1201D, will especially benefit by this simple installation since they have an extended range up to 10,000 cps with some contribution to the 12,000 cps region, and perhaps higher.

Use a funnel 4½ in. in dia. and 4½ in. deep. Saw off spout (Fig. 3) so there is an opening in bottom of funnel about 1½ or 1¾ in. in dia. Size of opening in bottom of funnel depends on size of high-frequency radiating area in center of cone, and on amount of highs you want to pass through funnel. Drill or burn with a hot needle 4 small holes through rim of funnel and suspend it in front center of speaker cone by means of strong fish line cord or small wire. Bottom of funnel should clear cone of large speaker by at least ½ to ⅝ in. to prevent damage to cone.

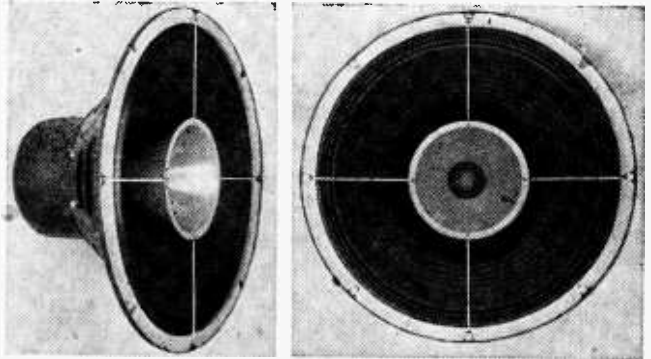

Dimensions given in this article work well with a 12 in. speaker; use a smaller funnel for an 8 in. speaker, and a larger one for a 15 in. speaker. —ARTHUR TRAUFFER.

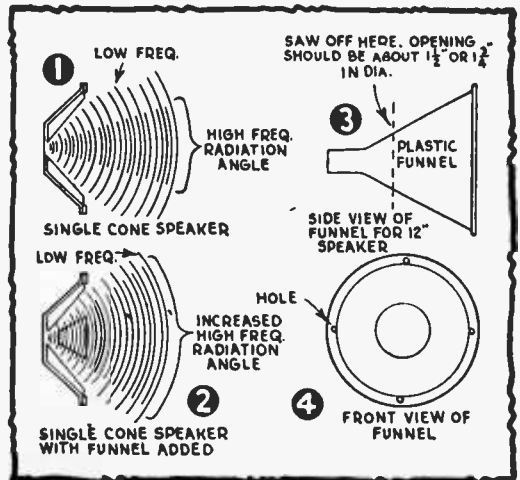

Pocket-Size Tube Checker

With this low-cost tester, you can locate a large proportion of all TV and radio tube failures!

By THOMAS A. BLANCHARD

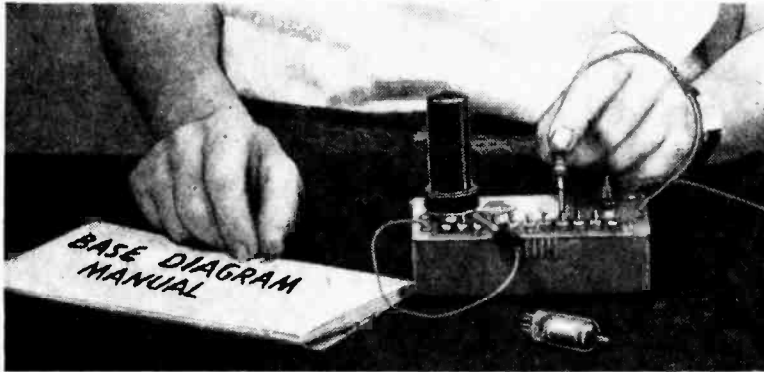

Fig. 1. Tube's condition is determined by reference to base diagram in inexpensive tube manual. Test probes reveal on neon lamp a shorted tube, or tube with burned out heater (filament).

THIS pocket-size TV and radio tube checker contains no meters or complicated parts and it costs just about \$1 to build. Naturally, you can't expect it to compare with a scientific mutual-conductance tester costing \$150. But it can locate most of the current TV tube failures, which are mostly "shorts" between elements, or open heaters (filaments). For the very best TV reception, it's wise to replace all tubes once a year. Save the old tubes as "spares" in case of a sudden tube failure.

This tester will handle all the latest type tubes used in TV as well as ac and battery radio sets made during the last 10 years (except for a few FM radio sets using "locktal" tubes). If you want to handle locktal tubes, you can expand the size of the checker and provide it with 4-, 5-, 6-prong and locktal sockets. The checker consists of a small neon glow lamp and 220,000 ohm 1/2-watt carbon resistor provided with a test clip and probe. The neon lamp operates off 115 v.

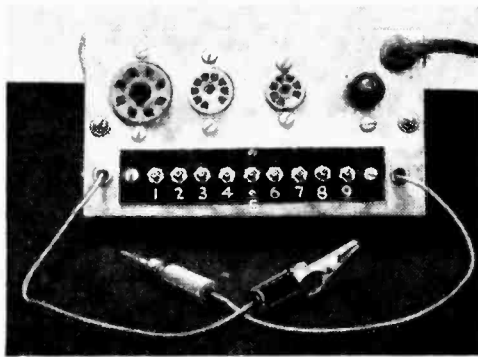
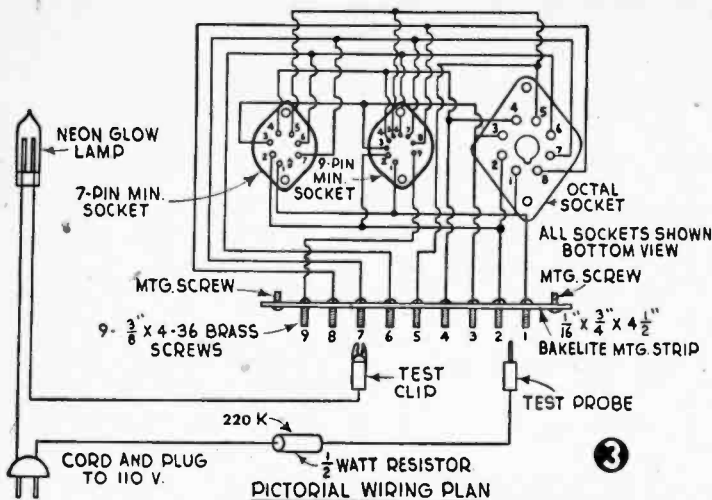

Fig. 2. Front of tester shows test strip, 3 sockets and neon glow lamp which shows tube condition.

ac-dc and provides a continuity check when a tube is inserted into any one of the 3 sockets on the panel. You'll also need a tube base manual which you can get from any radio supplier for from 25c to \$1.

Attach the clip to one of the 9 terminal screws representing a specific tube element as indicated in the base manual. The remaining probe wire is then run along the remaining pins for checking. To determine a burned out "heater," check the basing manual for the heater pins. Many octal tubes are wired with heaters on #2 and #7. Therefore, attach the clip lead of tester to terminal screw #2. Contact the probe lead on screw #7. If the neon lamp glows, the tube filament is okay. Radio and small screen TV sets frequently have series-wired heaters. When one tube "blows," several tubes may go out. This checker is ideal for this test.

While sets with parallel-wired heaters only result in the one bad tube being out—the other tubes usually having a visible glow—(except metal tubes which you can feel to determine whether heater is okay, but *don't try feeling tubes in high voltage compartment!*) a few tubes are too dim to be seen. TV high voltage rectifiers like the 1B3GT are among those parallel-wired types where this tester is useful. This checker is especially handy in its ability to reveal internal shorts between elements when the tube is cold. The three sockets on the checker are wired in parallel: all #1 socket lugs are wired to Screw #1; Lugs #2 to Screws #2, etc.



MATERIALS LIST—
TV TUBE CHECKER

- 1—Alum. panel 14 gage 3x4½" (optional)
- 1—Bakelite strip, 1/16x¾x4½" (only needed if checker is built on metal panel)
- 11—¾ by 4-36 brass screws. 9 used for test pins; 2 as mtg. screws
- 11—4-36 nuts
- 1—Each: Insulated alligator test clip, and phone tip
- 2—rubber grommets for ¾-in. dia. holes
- 1—180,000 or 220,000 ohm, ½ watt carbon resistor
- 1—NES1 neon glow lamp, ½ watt (½ watt neon with pigtail leads may be used.)
- 1—6 ft. fixture cord and plug
- 1—Tube base handbook (RCA Pin-index about \$1)

3

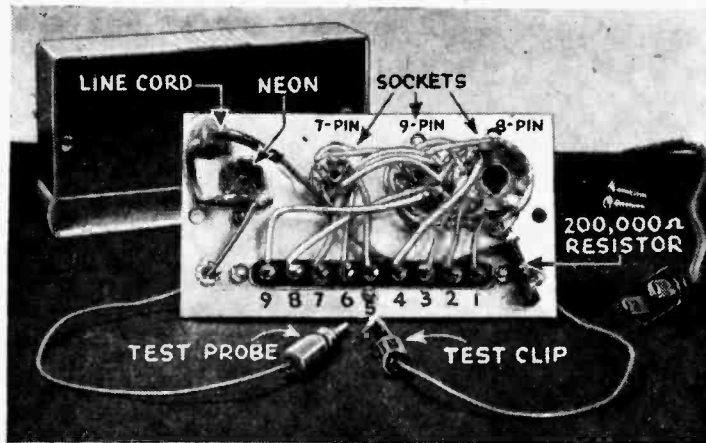

Fig. 4. Bottom view of tester. All alike tube base numbers are connected together to screw having same number on test strip.

Thus, referring to the basing manual, place the clip lead on a heater screw. With the remaining probe, check the cathode (K) screws. If neon glows, tube is shorted from heater to cathode. Next, place clip on cathode screw (number determined by basing manual) and check G¹; then check G¹ and G², then G² and G³, and then G³ and P (plate). Finally, check P and IS (internally connected shield—if any shown on basing diagram).

Remember that if neon does not glow on H-H, the test tube is burned out and no good. If neon glows on any test other than that on the heater, it indicates a short and tube is also discarded. In the latter tests between grid, plate, cathode, diode, or the internal shield, observe the basing plan carefully. Some tubes may have a grid, for example, terminated on two pins, say 3 and 5. Naturally the lamp will glow if probes are on Screws 3 and 5 and this does not indicate any defect whatsoever.

Some tubes have an internal shield (IS) and suppressor grid (G³) internally connected and brought out to a common tube pin. But in your

tests, just watch the reaction of the neon glow lamp in pin-to-pin tests between isolated elements shown on the base diagram.

This checker was assembled on a panel of 3 x 4½-in. 14-gage aluminum (Figs. 2 and 4). Drill holes for the 1-in. dia. octal socket, the ¾-in. dia. 9-pin miniature socket, and the 5/8-in. dia. 7-pin miniature socket. Provide a 5/16 x 3 1/2 in. slot across the panel for clearance of the test pins. These pins are 3/8 by 4-36 brass screws spaced 3/8 in. apart on a 1/16 x 3/4 x 4½-in. Bakelite strip.

Next drill two 3/8-in. holes in the panel for the rubber grommets; one grommet provides a mounting for the small neon glow lamp, while the other serves as insulation for the fixture cord. Make a 1/4-in. hole on each side of the test strip for the test-probe leads.

The sockets used on the tester shown here are Amphenol molded Bakelite types. While wafer sockets may be used, the molded sockets have the pin numbers right on each socket so that there is minimum chance of wiring errors. As previously stated, these socket numbers all wire to the corresponding screw number on the test screw-pin strip. The aluminum panel isn't a must—you may build this tester in any size or shape con-

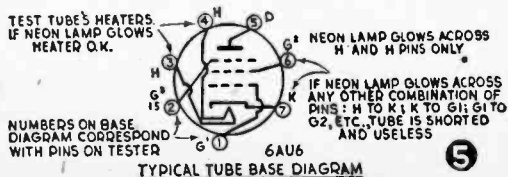

5

tainer that may be available.

In using your tester always hold the test tube by the insulated plastic grip. While this tester is 100% shockless, the neon lamp is so sensitive in its response that holding the metal test leadtips—one in each hand—will cause the lamp to glow brightly. Standing on a cement floor and holding just one test lead will produce a medium glow.

While a dead short between tube elements usually produces a brilliant glow, a medium glow denotes an inter-electrode capacity breakdown, gassy tube, etc. An extremely feeble, almost invisible neon lamp glow usually indicates that the tube may be used, but you should have it checked at your radio dealer, on his mutual-conductance tester if he has one.

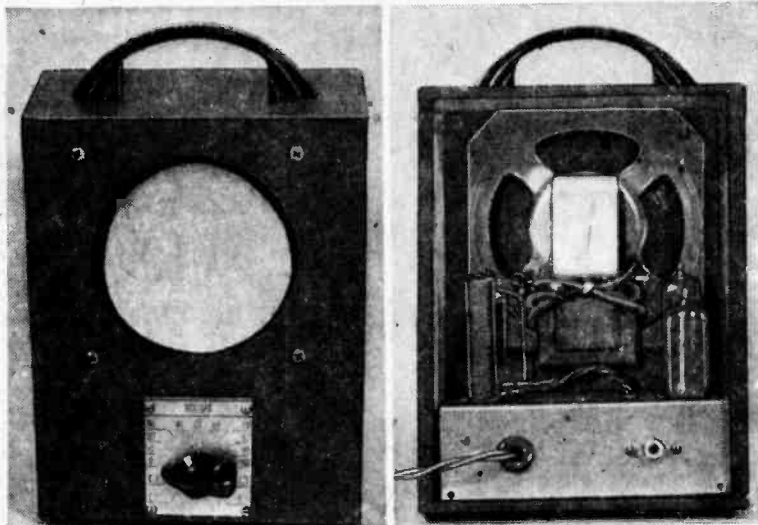

Left, red plastic fabric and molded handle give amplifier professional look. Cigar-box cabinet is only 5" wide and 7" high. Right, rear view with chassis and speaker in cigar-box housing. Speaker is installed with transformer down. Chassis may be removed without disturbing speaker and transformer.

sensitive crystal mike may be used with this unit. For greater voice strength, use a quality carbon microphone and transformer fed by one or two flashlight cells. Among many other applications, this miniature amplifier may be used as a light beam broadcast receiver.

The extreme compactness of this amplifier is made possible through use of the new miniature ac-dc type tubes now on the market. No special or trick apparatus was used in constructing the model shown. The parts are 100% standard so that any person following the picture diagram can duplicate this outfit.

Miniature Multi-Purpose SOUND SYSTEM

This versatile, cigar box size amplifier plays records and "electrifies" guitars. Its terrific power will amaze you!

By THOMAS A. BLANCHARD

HERE'S a really practical piece of electronic equipment every radio experimenter will want to own. It's a miniature *public address outfit*—an amplifier so small that it is housed, speaker and all, in a streamlined cigar box—and it has so many uses we can't name them all here. Plug in a phonograph crystal pickup and this unit can play records with more volume than your ears can stand. Or attach it with a contact pickup to a string instrument and you have an electric guitar, banjo, etc. For voice reproduction, a good,

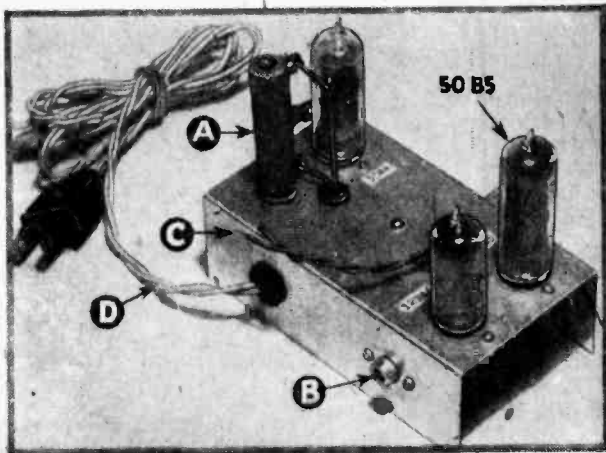

At right, is a close-up of chassis. A. 150 ohm voltage drop resistor; B. mike or pickup input jack; C. leads to speaker transformer; D. Line cord.

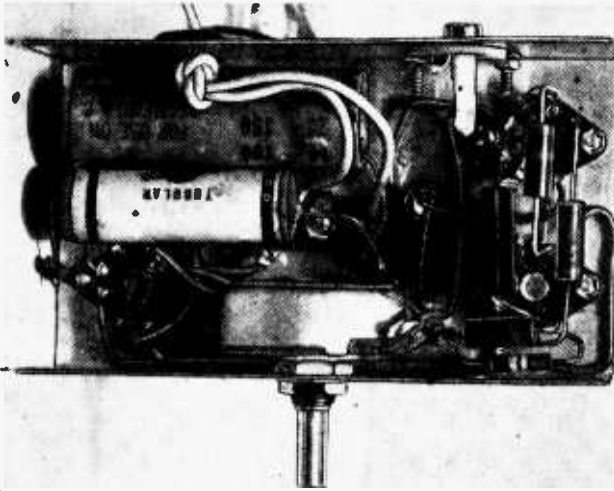

Bottom view of amplifier. Note that actual parts arrangement is identical to pictorial wiring plan.

cent to the tube sockets, add two 1/4 in. holes for the speaker leads and wires to the line drop resistor. The line resistor is a 10-watt, 150 ohm value mounted by a single machine screw in a vertical position next to the 35W4 rectifier tube. Resistor and tubes are arranged along the edge of chassis so that the center area is unobstructed to clear the speaker and transformer mounted under it.

A 2-post soldering lug strip is attached to the underside of the chassis so as to provide a convenient junction for the line cord, and the other component leads which are connected to this strip (see pictorial or schematic diagram). There is no

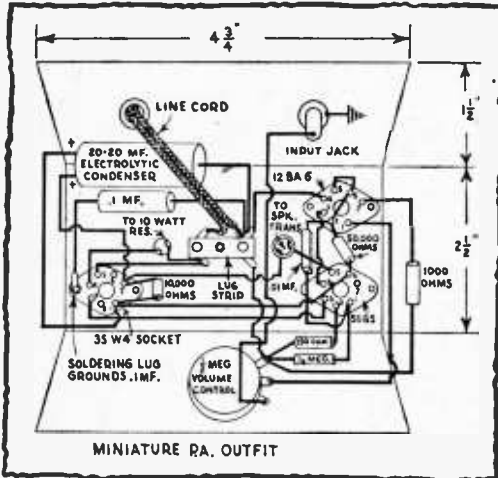

Materials List—Sound System

CHASSIS:

Form from aluminum or steel blank size 4 3/4"x5 1/2". Bend up both sides to form channel 4 3/4" wide, 1 1/2" high, and 2 1/2" deep.

CABINET:

Made from cigar box. See text.

RESISTORS:

- 500,000 ohm (1/2 meg.) Volume Control
- 250,000 ohm (1/4 meg.) 1/2 watt resistor
- 50,000 ohm 1/2 watt resistor
- 10,000 ohm 1/2 watt resistor
- 1,000 ohm 1/2 watt resistor
- 150 ohm 1/2 watt resistor
- 150 ohm 10 watt resistor (wire-wound)

CAPACITORS:

- 20-20 Ml., 150 V. Miniature Electrolytic
- .1 Mf. Tubular Condenser
- .02 Mf. Tubular Condenser (Optional; output noise filter)
- .01 Mf. Condenser

MISC. COMPONENTS:

- 3 7-Pin Miniature Sockets
- 1 Phono-Input Jack and Plug
- 1 4" PM Speaker with Output Transformer for 50L8 or 50B5 tube
- 1 Length fixture cord and plug
- 8 R.H. Machine screws and nuts size 3-48 x 3/8"
- 4 Rosette Head Screws and nuts size 6-32 x 3/8"
- 1 Volume Escutcheon Plate and Bar Knob
- Tubes: 50B5, 12BA6, 35W4

Before starting construction, obtain a suitable cigar box for the cabinet. A box required to fit our chassis dimensions must measure inside at least 3 1/4 in. deep, 4 3/8 in. wide, and 6 1/2 in. high. The box used may be larger, but not smaller. This type of box usually contains 50 cigars so you are sure to find one at your favorite newsstand.

The chassis is formed from a piece of aluminum or steel 4 3/4 in. wide by 5 1/2 in. long. Measure 1 1/2 in. on the 4 3/4 in. dimension and bend panel to form finished chassis so that it assumes the channel shape shown. A 3/8 in. hole is provided in the center of the front apron for the volume control. Two additional 3/8 in. holes are punched in the rear apron for "input jack" and power cord.

Three 3/8 in. holes are cut into the top of the chassis in the positions shown, for allowing the mounting of the miniature tube sockets. Adja-

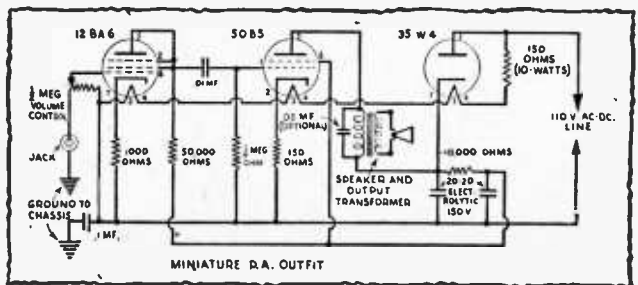

reason why the most inexperienced can't build this amplifier by closely following our picture plan, making certain that he has made connections to the proper tube socket lugs, and inserted parts using well soldered connections.

Note that all tube socket lugs are not used. Our readers from time to time think "*something was left out.*" All tubes are designed with uniform pin systems for manufacturing convenience. Some tubes may use all pins provided; others may not. Therefore, make connections as shown.

When wiring to tube sockets, also bear this in mind: Tube element designations are read from the bottom of the socket—not the top! Miniature sockets are numbered 1 to 7 in consecutive order. The numbers in schematic diagrams appear out of order simply because it would be more confusing to draw elements of the tube in clockwise sequence, as they actually exist on the socket. Finally, note that in the miniature socket pin arrangement, there is *one wide space*. This is your start and finish. With wide space toward you, the first pin on the left is No. 1. Then reading clockwise around the socket you have No. 2

next, then No. 3, No. 4, etc.

If 500,000, 250,000, or 50,000 ohm resistors are not available, constructor may substitute 470,000, 270,000 and 47,000 ohm values.

The amplifier wiring is completely pictured in the pictorial plan as well as all components except for the speaker and output transformer attached to speaker frame. The two wires passing through the righthand center chassis hole connect to this transformer. The two wires passing through lefthand center chassis hole connect to the two lugs on the 10-watt, 150 ohm resistor. Otherwise, *all wiring is clearly visible!*

The striking appearance of the cigar box housing was achieved by covering it with brilliant plastic coated Cello-Fabric. This material was attached to the box with book paste. A chrome trimmed plastic handle and chrome volume control dial provided the finishing touches. A piece of silk, 4 x 4 in., cemented inside the box, made a neat speaker grill. The speaker opening was cut with a "fly-cutter" but you can work cigar box wood with a small keyhole or jig-saw.

"Wireless" Pickup Amplifies Phone Talks

A standard earphone, with cap and metal diaphragm removed, is taped over telephone receiver. Voice comes over the loudspeaker.

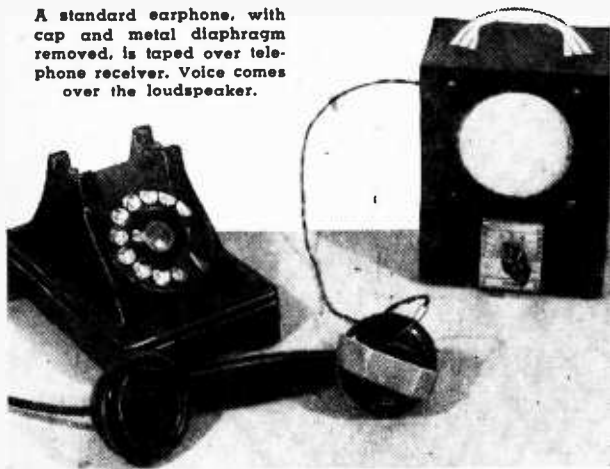

A radio earphone makes a simple inductor pickup to send a phone call through your radio speaker

AMPLIFYING a telephone conversation so that the caller's voice can be heard by any number of people is simple. There are several methods of obtaining "wireless" connection to any phone. The two methods described in this article are inductive pick-up systems.

The easiest method requires only a radio receiver provided with a phonograph pickup jack. Many sets have such a connection on the back of the chassis. Otherwise, such a jack may be provided. Better yet, if you use the Multi-Purpose Miniature Sound System (described in the preceding article), the voice of even a long-distance caller will be heard loud and clear.

The telephone pickup consists of a single radio earphone with a resistance of 1000 ohms or more. While even an ancient earphone may be used, much better results will be obtained from one of the newer receivers having an Alnico magnet. Many war surplus headsets are of the Alnico type. Unscrew the plastic earphone cap, lift off the metal diaphragm and disconnect the cord (if earphone is obtained from a double headset). Now connect a new pair of wires, using rubber-covered fixture wire, to the earphone lugs and connect a radio-phono plug to the opposite end of the fixture wires.

Leave earphone cap and diaphragm just as they are and attach the open unit over the telephone's receiver with Scotch tape or heavy elastic band. To obtain proper polarity between telephone receiver and earphone pickup, turn or rotate earphone slowly until loudest dial tone comes in. A drop of red nail polish on phone receiver and earphone edge will identify the proper position

for future use.

In some instances, the pickup is more sensitive when phone receiver cap is unscrewed and earphone placed against phone receiver's diaphragm. However, very modern phones have a cartridge type receiver which disconnects when cap is removed. For all practical purposes—unless you know exactly what you are doing—do not remove the receiver cap on telephones as the pickup will work in most cases as first described.

Another pickup which connects to the amplifier or phono-pickup jack in the same manner as the earphone pickup, is a homemade induction coil consisting of several hundred turns of No. 40 gage enameled magnet wire.

Form a cylinder 3 in. in diameter from light cardboard, holding it in shape with Scotch tape. The tube should be long enough to handle since it is removed after coil has been wound. Wind 400 or more turns of magnet wire onto the tube, keeping the turns within a $\frac{3}{4}$ in. space. Scramble-winding is adequate for our purpose. When finished, secure coil around its circumference with adhesive tape.

The completed coil is too delicate to withstand rough handling and should be placed inside a

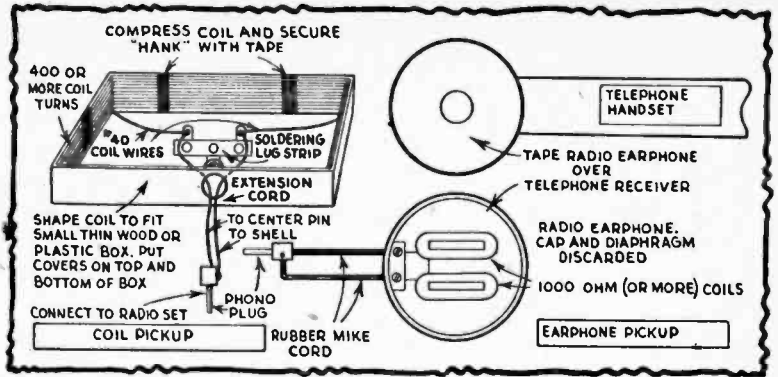

shallow plastic or wooden box. A two terminal soldering lug fastened inside box permits fine magnet wires to be joined to fixture cord extension connecting to jack on radio or amplifier. Be sure enamel insulation is removed from ends of magnet wire before soldering to lug strip or an open circuit will result. Wireless pickup is obtained by laying telephone receiver on coil box, or by placing box under phone base, depending on type of telephone.

Of the two pickup methods described, induction coil method is best for all around purposes. There are some instances where the simple earphone method may not work to complete satisfaction. For a very sensitive induction pickup, use the secondary winding from an old Model-T Ford spark coil. This eliminates the necessity of winding your own coil.

Mechanical Pencil Holder for Small Tools

• A mechanical pencil holder of the type using large leads which are clamped in place by a chuck arrangement on the pencil can become a useful tool.—HARRY F. LEEPER.

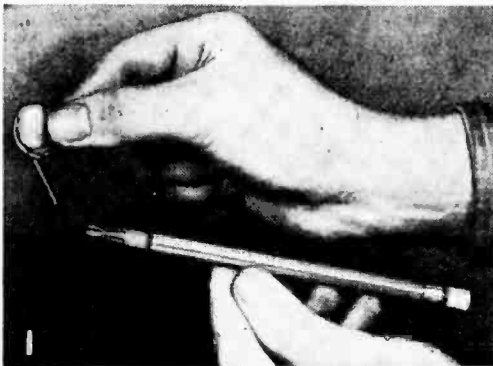

Fig. 1. Clamp a small dental mirror in the pencil, and use it to identify hidden radio parts' values or examine nameplates on appliances.

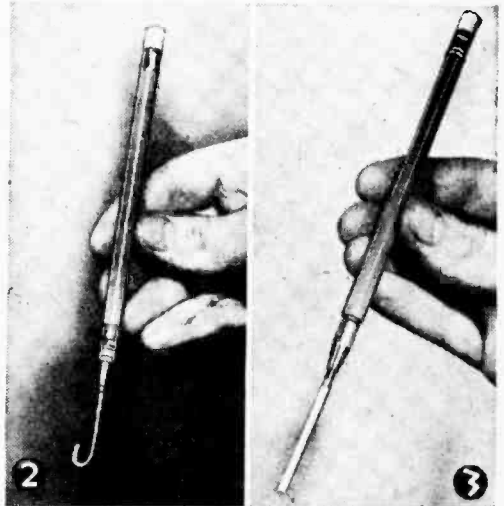

Fig. 2. A piece of hooked wire makes a convenient probe for pulling on suspected loose wires.

Fig. 3. A pipe cleaner placed in the pencil jaws gives added length to clean radio condenser plates, apply cement or cleaner to contacts.

Record Player Built in a Drum

By THOMAS A. BLANCHARD

THIS record player built for a 7-year-old has the volume and tone of commercial players costing as much as \$30. Yet the original model was built from odds and ends and the only cash outlay was 50c for the dime store toy drum.

Although drum is but 5 in. high and 11 in. in diam., sufficient room is available for installing a standard 33 or 78 rpm phono motor, crystal pick-up, 4 in. PM speaker, and 3 tube amplifier. The turntable is a large 9 in. size and the pick-up arm is long enough to play 12 in. records. A phono motor with a 7 in. turntable may be used if more compactness is desired, but some loss in playing quality may result, as a small, light-weight turntable often produces "warbled" music. The amplifier used in this project was described on page 133 of this Handbook. If volume control shaft bushing is long enough, secure amplifier to wood mounting plate with one $\frac{3}{8}$ in. nut. Otherwise, pierce front apron of chassis with an ice-pick or awl, and attach chassis to mounting plate with two self-tapping screws of suitable length.

Before constructing mounting plate, assemble all the other radio components to determine mounting holes and proper fit. Cut mounting plate, a disc 10 $\frac{5}{8}$ in. in diam., from a piece of ordinary box grade $\frac{3}{8}$ in. thick pine. Next cut a 4 $\frac{1}{2}$ in. diam. hole for insertion of phonograph

Bottom view of drum with PM speaker at left, phono motor at upper right, and 3-tube amplifier at lower right. Drumhead springs in foreground.

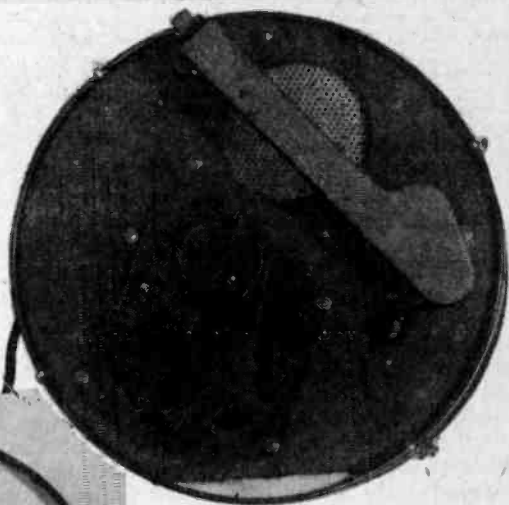
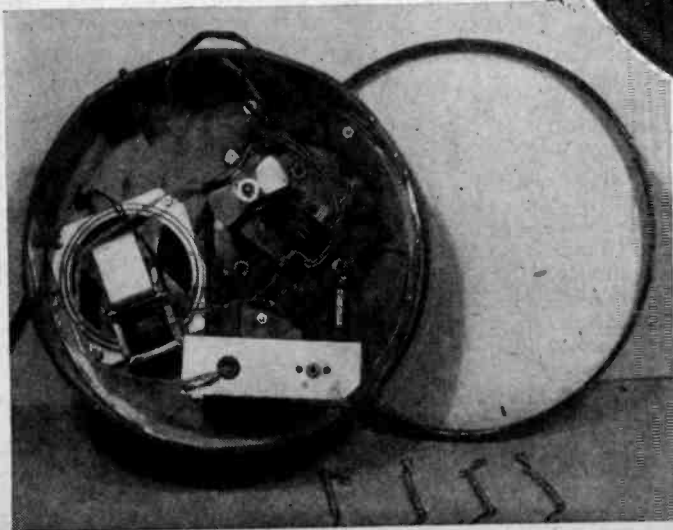

With turntable off, note pick-up, motor plate and speaker positions. Perforated plate protects speaker cone.

motor and a 3 $\frac{1}{2}$ in. diam. hole to serve as speaker baffle. Mount motor plate on top of wood disc, and speaker on bottom of disc with $\frac{1}{2}$ x 6-32 rh (roundhead) machine screws and nuts. Drill mounting holes in accordance with holes of motor plate and speaker frame (because of manufacturers' variations, these are not shown). Holes for phono pick-up and volume control bushing are shown in approxi-

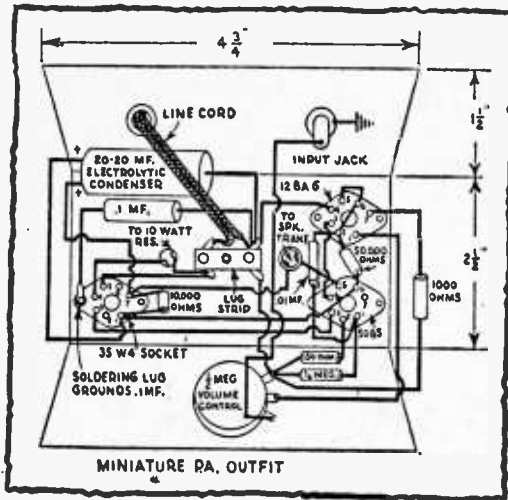

MINIATURE PA. OUTFIT

MATERIALS LIST—DRUM RECORD PLAYER

- 1 toy drum, 11" dia. Made by J. Chain & Co., 200 5th Ave., N. Y. C., available in 5 and 10c stores
- 1 sq. ft. $\frac{3}{8}$ or $\frac{1}{2}$ " pine
- 1 4" PM speaker with 50L6 or 50B5 output transformer
- 1 phonograph motor, General Industries or Alliance, with 9 or 7" turntable. 78 rpm, 115 v. A.C., 60 cy.
Note: For playing Microgroove records only, similar motor may be obtained with 33 rpm speed
- 1 crystal phono pickup; Astatic, Webster, etc. Std. type
Note: Use special "LP" pickup for Microgroove records. Astatic, Webster, etc.
- 1 miniature amplifier
- 1 6 ft. extension cord and plug
- 1 single pole, single throw toggle switch
- Misc. hardware as described

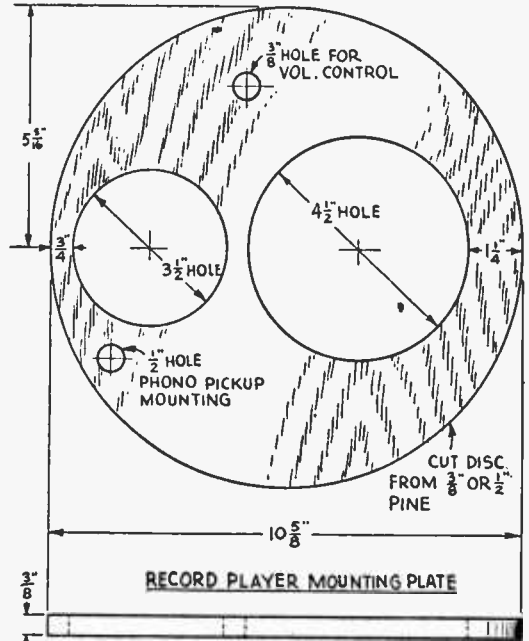

RECORD PLAYER MOUNTING PLATE

around metal flange and fasten disc and flange into a rigid assembly with small rh wood screws.

In metal drum frame, punch a $\frac{1}{2}$ in. hole for a toggle switch and a $\frac{3}{8}$ in. hole for line cord to pass through. Fit $\frac{3}{8}$ in. hole with a rubber grommet to protect cord from damage by sharp metal edges. Wire cord and switch to both amplifier and motor. Place paper-intact drumhead on bottom, then metal frame, and finally player assembly. Replace four drumhead springs and record player is ready for your youngster.

mate positions they will assume. Slight shifting of amplifier and pick-up mounting may be needed to clear internal speaker of motor obstructions.

After all holes have been determined and provided in wooden disc, it may be given a professional finish with flock, finely pulverized rayon and felt heavily sprinkled on wet quick-drying enamel of the same color. After enamel has dried, brush excess off disc, leaving a professional fabric-like surface. Some radio suppliers sell a complete kit including flock in shaker can, undercoat enamel and brush, while flock may be obtained alone in a number of colors at art stores. A flour sifter may be used to sprinkle on the flock. Both mounting plate and photo turntable of juke box shown were finished in royal blue to contrast with the red, yellow and blue drum.

With all parts mounted assemble the player in drum, first unhooking the four spring clips which secure drumheads. Leave one drumhead intact, but cut out parchment paper "skin" of the other, allowing about $\frac{1}{2}$ in. to remain around flange so wood disc carrying mechanism will be supported in flange by the stiff paper remaining around edges. Then drill or punch six equi-distant holes

Solderless Tube Sockets

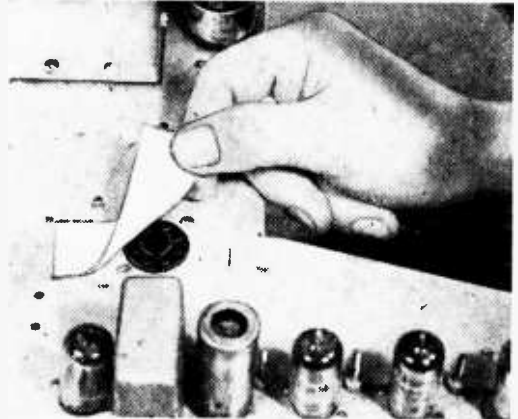

• When soldering on top side of radio or TV chassis, dropping solder in an open tube socket can cause trouble. Eliminate this possibility by placing a strip of wide adhesive tape over the open socket.—H. LEEPER.

Two-Tube Battery "DX-er"

By MILO ADLER



THIS highly efficient radio, designed for maximum sensitivity and minimum battery drain, is sensitive enough to "pull in" stations from all over the world when receiving conditions are correct. The receiver uses 6 ready-made 4-prong coils covering everything from 9.5 to 550 meters (31.5MC to 550 KC) which includes amateur, police, commercial and broadcast bands. These factory wound coils eliminate cut-and-try methods usually required when you make your own coils.

The first 1S5 tube is used as a triode in a stable regenerative grid-leak detector circuit; second 1S5 tube is connected as a high gain pentode audio amplifier. The amplified audio output is delivered to a pair of headphones in the plate

circuit. The use of these low drain tubes keeps the A and B battery drain at about 5 milliamperes (ma.) maximum with 3 ma. average for the 90v. B and 100 ma. for the 1½v. A battery, which prolongs the battery life.

To add an additional tube and a speaker, disconnect negative B battery lead at terminal A on the regeneration control and reconnect the lead to -90v. terminal shown in Fig. 4. Termi-

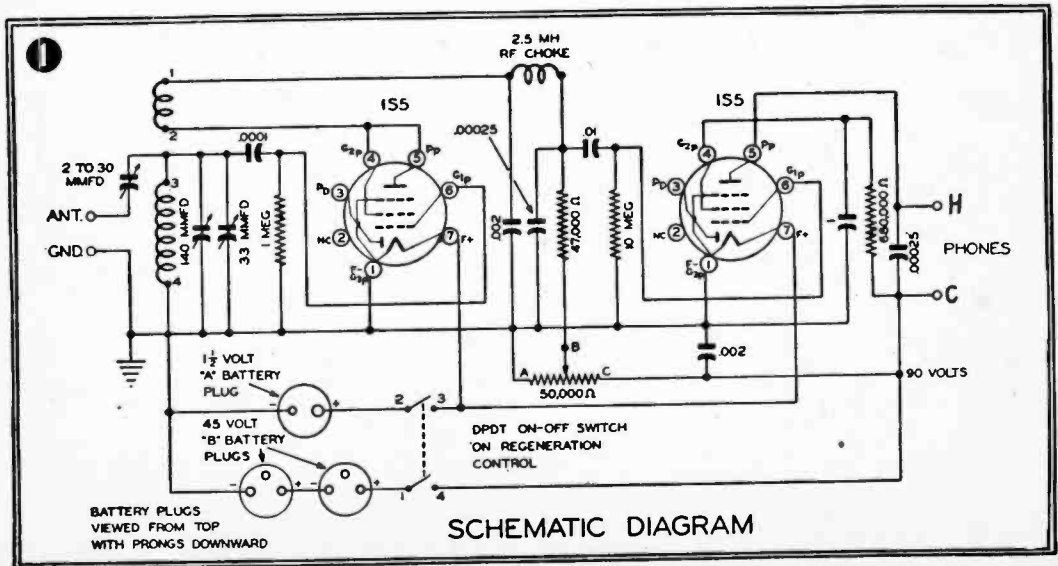

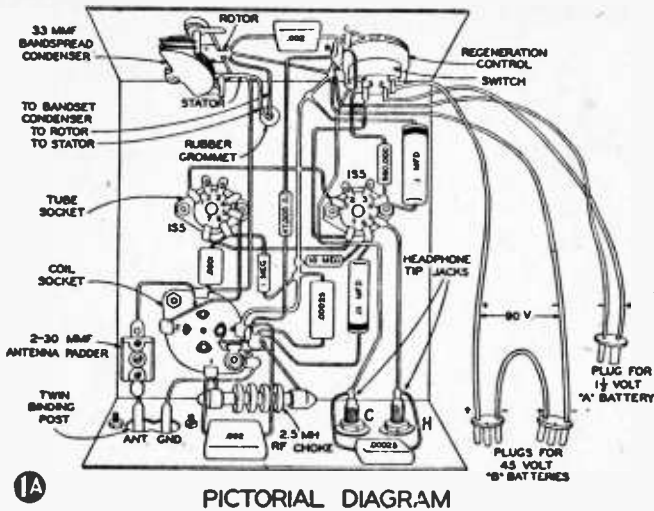

nals H and C in Fig. 1 connect to corresponding phone terminals in Fig. 2; terminals A and 3 connect to the regeneration control.

Front panel controls are the main tuning or "band-set" condenser for tuning to approximate

wired last and kept close to the chassis.

Solder all connections, using rosin core solder only (acid core solder and acid flux cause corrosion and eventually, break down). Pre-heat parts for better work by holding soldering iron

frequencies, band-spread condenser for fine tuning, and regeneration control combined with on-off switch. A series antenna trimmer condenser controls the antenna coupling for each band, thereby providing a considerable increase in efficiency.

When mounting the 2 tube sockets and coil socket, rotate the sockets so they are in the same position shown in the pictorial diagram. Layout of parts provides short connections without excessive crowding. Heavy #16 bus wire running to all ground points, provides a good ground for all parts and improves performance. Use insulated washers on the phone tip jack. In wiring, keep wires and pigtail leads from resistors and condensers as short as possible. Clip off excess wire. Wiring will be easier if resistors and condensers are

MATERIALS LIST—2-TUBE "DX-ER"

- 2 1S5 tubes
- 1 .0001 mfd. mica capacitor
- 2 .00025 mfd. mica capacitor
- 2 .002 mfd. mica capacitor
- 1 .01 mfd. 400 volt tubular capacitor
- 1 .1 mfd. 400 volt tubular capacitor
- 1 2 to 30 mmfd. antenna padder
- 1 33 mmfd. bandsread capacitor
- 1 140 mmfd. bandset capacitor
- 1 1 megohm, 1/2 watt resistor
- 1 47,000 ohm, 1/2 watt resistor
- 1 10 megohm, 1/2 watt resistor
- 1 680,000 ohm, 1/2 watt resistor
- 1 50,000 ohm regeneration control (Mallory MR33)
- 1 DPST switch cover (Mallory M27)
- 2 7 prong miniature socket
- 1 4 prong water coil socket

- 1 twin "Antenna-Ground" binding post
- 1 2.5 mh. r.f. choke
- 2 phone tip jacks
- 2 45 volt, 3 prong battery plug
- 1 1 1/2 volt, 2 prong battery plug
- 2 1 1/4" bar knobs
- 1 2" pointer bar knob
- 1 5x5x2" chassis
- 1 5x5 1/2" panel
- 1 Set of "Broadcast" plug-in coils
- Hook up wire, bus wire and solder
- Hardware consisting of:
- 4 each—4-36x1/4" machine screws and hex nuts, 6-32x5/16" machine screws and hex nuts;
- 1 each—1/4" grommet, No. 6 solder lug and single insulated tie lug.

- 2 Burgess M30 "B" batteries (45 volts)
- 1 Burgess 4F "A" battery (1 1/2 volts)
- 1 Short wave coil kit

POWER AMPLIFIER PARTS

- 1 680 ohm, 1/2 w. resistor
- 1 220,000 ohm, 1/2 w. resistor
- 1 2.2 megohm, 1/2 w. resistor
- 2 .005 mfd., 400 v. capacitor
- 1 10 mfd., 150 v. electrolytic capacitor
- 1 10,000 ohm plate to voice coil output transformer
- 1 3V4 tube
- 1 7 prong miniature tube socket
- 1 5" permanent magnet speaker

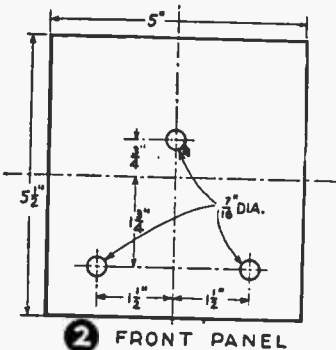

Rear view showing "bandset" condenser, coil, and antenna, ground and earphones connected.

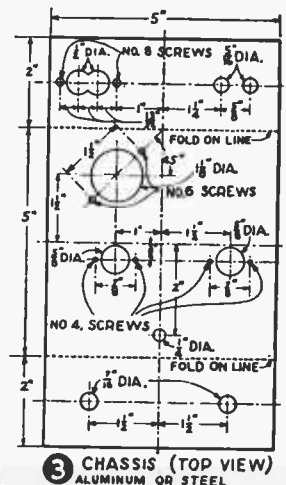
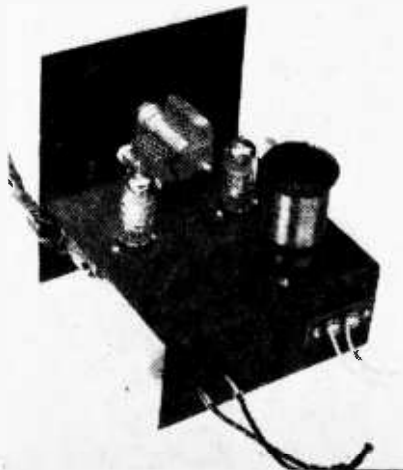

tip against wire and terminal for a few seconds. Then apply just enough solder to cover connection and fill crevices between the wires. Remove the iron, but do not move wires until solder has set (this takes only a few seconds). When more than one wire is connected at a particular point, don't solder this point until all the wires have been connected to that point. To do good soldering, iron must be well tinned and the connections mechanically secure before any solder is applied.

Use one of the broadcast coils to test the receiver. Plug it into the 4-prong socket, connect antenna lead-in wire to antenna binding post, connect a ground wire to the ground binding post. For a good ground, drive a 6 ft. length of pipe into earth that is always damp or wet or use a radiator or water pipe.

Plug earphones into 2 phone tip jacks, plug battery plugs into batteries, and turn on the switch. Note lighted filament as a very dull red glow in center of tube as tubes warm up. Next advance regeneration control clock-wise until you hear a thud and a hiss in the earphones; this is the critical point of oscillation. Now adjust antenna trimmer for maximum capacity possible while maintaining critical oscillating point over the entire tuning dial. Receiver is now adjusted for maximum sensitivity. For greater selectivity, set trimmer at a lower capacity. Music and speech are best received with regeneration control set just below critical point of oscillation; code (C.W.) stations are received with the control just above this point.

Tune for a station with the main tuning dial,

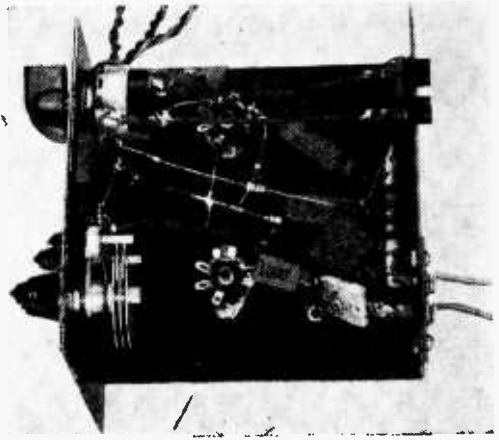
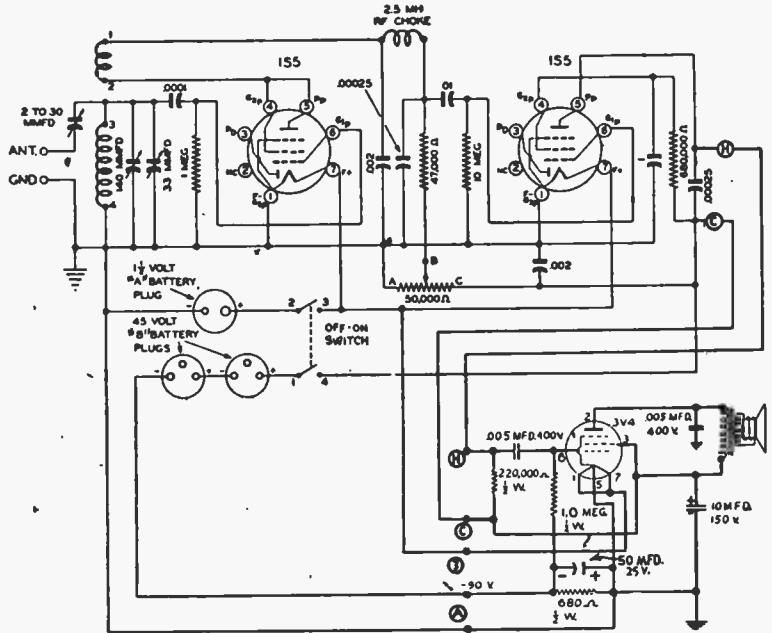

Bottom view showing wiring and positions of "bandspread" condenser and regeneration control.

at the same time maintaining highest point of sensitivity. After signal is heard, readjust regeneration control for clarity. For greater separation of stations within a band, use the bandspread condenser. Short-wave tuning must be done very carefully as the signals are very sharp and occupy a small space on the dial. For best results tune around the 49-meter region at night and around 25 meters in the daytime. Antenna trimmer adjustment is critical on short wave. Adjust so that the set regenerates over the entire band of coil used. You will become adept at this with a little practice.

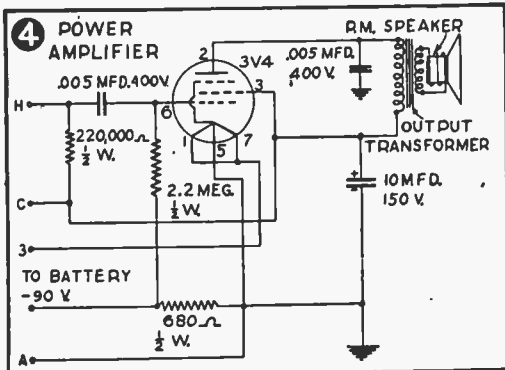

• Complete kits for constructing battery sets may be obtained from Dept. 3X, Allied Radio Corp., 833 W. Jackson Blvd., Chicago 7, Ill.

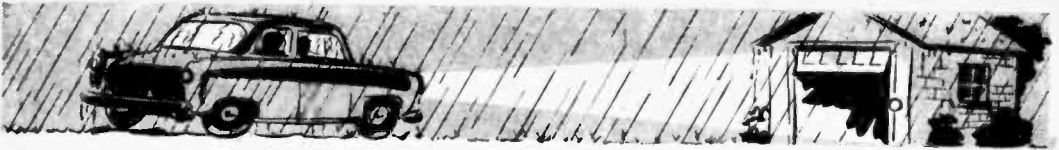

Fig. 1. Photocell unit and door in operation.

the car. Then, without setting foot outside, simply press a wall button 3 times, and the door closes all the way down. These are the jobs this electronic garage door opener will do for you. It is especially designed so that it works with a standard Crawford garage door. No additional equipment need be installed in your car to make it work. When properly adjusted, the control unit will operate the door at high noon as well as it will at midnight. Here's how it works.

The beam from your car headlights strikes the photocell unit (Figs. 1 and 4), which is mounted on the wall of the house at the correct height (Fig. 1). Light passes through a 3 in. lens in photocell unit and is focused through a small hole in a baffle plate (Fig. 2). This hole allows only the rays entering on a direct line from the headlights to strike the cathode of a

Headlight-Controlled Garage Door Opener

By ALFRED BROSEAU

TURN into the driveway, blink your headlights 3 times and sit comfortably at the wheel while the garage door rolls up (Fig. 1) and comes to an automatic stop. Drive in and park

lens in photocell unit and is focused through a small hole in a baffle plate (Fig. 2). This hole allows only the rays entering on a direct line from the headlights to strike the cathode of a

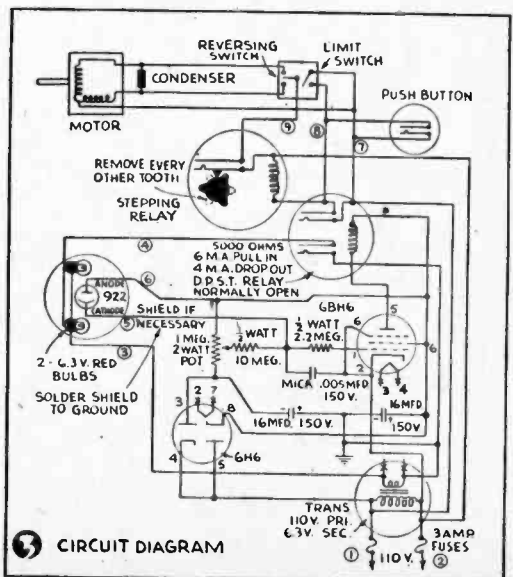
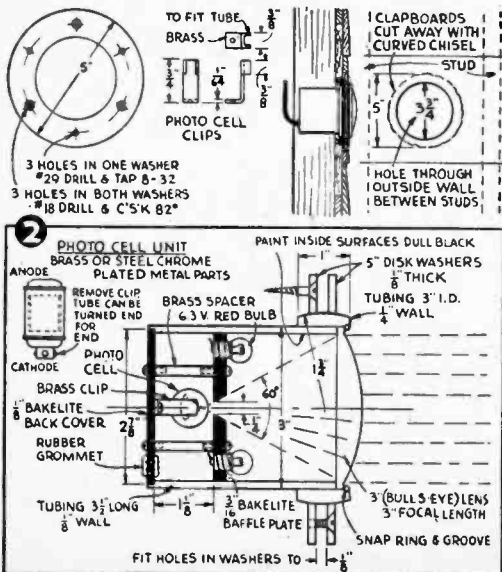

CIRCUIT DIAGRAM

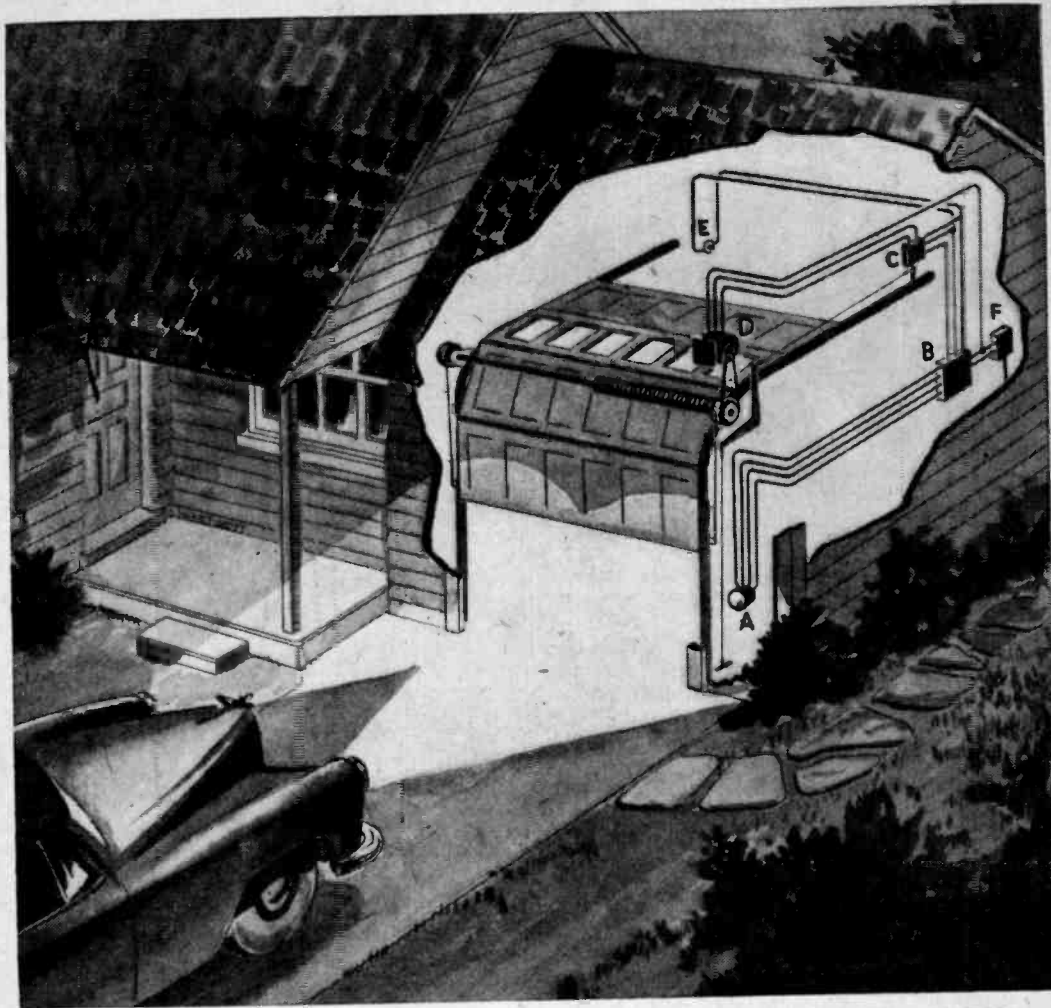
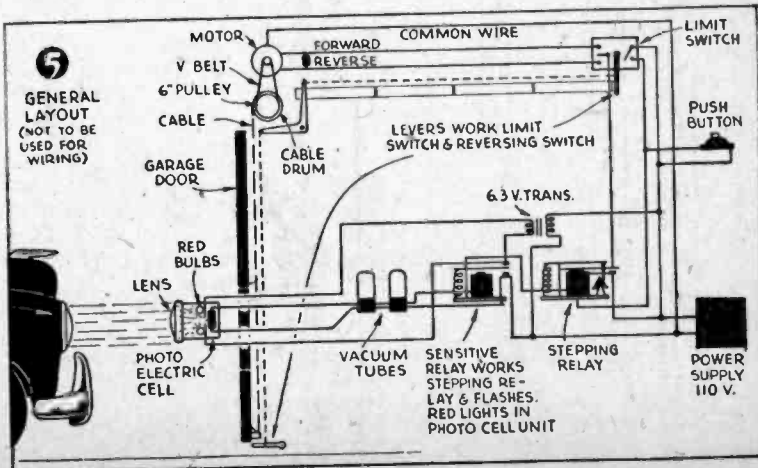

Fig. 4. Cutaway drawing showing location of major elements of garage door opener installation. By flashing headlights 3 times, photocell (A) sends impulses to control circuit (B) which completes circuit at switch box (C), causing motor (D) to lift garage door. Door stops motor when it strikes lever at switch box (C) which sets up reversing switch. After driving in, press push button (E) 3 times and door closes. (F) is electric power supply.

#922 photoelectric tube (Fig. 3). When the light strikes the photoelectric tube it changes the resistance in the circuit, allowing the current to flow through a sensitive relay. The relay in turn closes the circuit to the stepping relay. This action, repeated 3 times, closes a set of contacts, starting the motor, which winds up the cables on the drums (see Figs. 5 and 17).

These cables raise the garage door until it



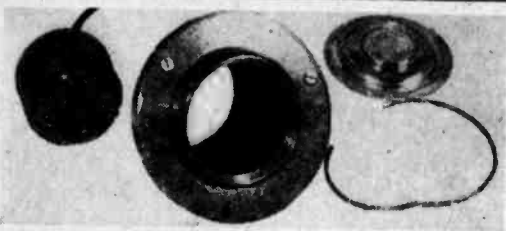
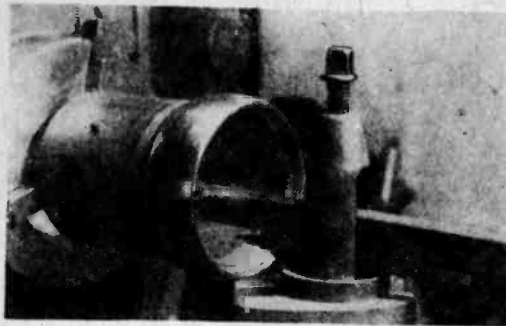

Fig. 6. Machining the photoelectric cell unit. Fig. 7. Parts of the photoelectric cell unit.

moves a lever attached to the cam inside the switch box (Figs. 5 and 12). The cam operates the switches. One microswitch closes momentarily to step the relay ahead to shut off the motor. The door continues to move a short distance after the motor is cut off and this movement is enough to set the reversing microswitch. Pressing the wall button inside the garage 3 times then sends 3 impulses to the relay which starts the motor and unwinds the cables; the door then descends and closes by gravity.

Make up the photocell unit (Figs. 2, 6 and 7) from a shell of brass or steel tubing $3\frac{1}{2}$ in. long by 3 in. outside diameter. Cut off another piece of tubing to make a ring 1 in. long with a $3\frac{1}{2}$ in. O.D. and 3 in. I.D. Press the shell into the ring and then mount it in the lathe chuck and turn it to take the lens. Then cut a groove for the snap ring which holds the lens in place (Figs. 2 and 7),

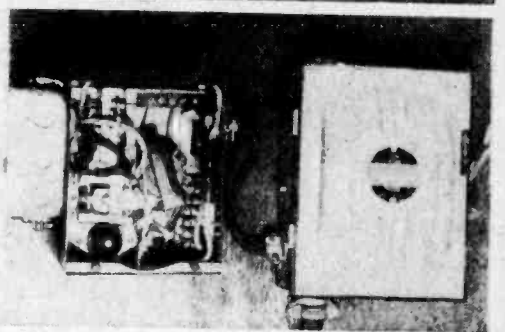
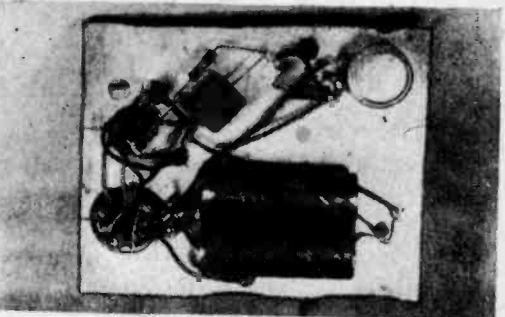
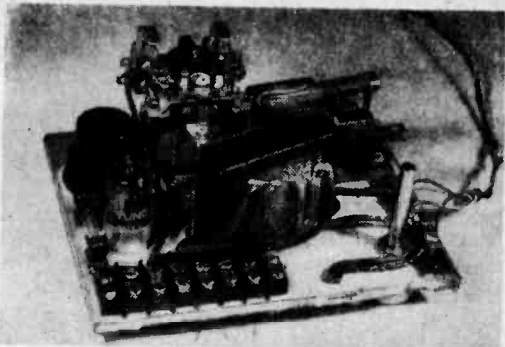
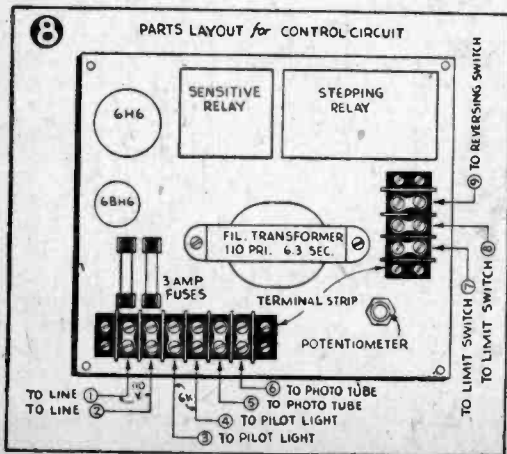

Fig. 9 (top). Control circuit parts on Masonite board. Fig. 8, which shows the improved parts layout, should be followed in preference to this photo. Fig. 10 (center). Underside of Masonite board. Fig. 11 (bottom). Control circuit installed.



Without removing the piece from the lathe, turn the ring to form part of a ball. Now reverse the unit in the lathe chuck and turn a recess for the back Bakelite cover. Next bore out 2 large discs or washers a little smaller than the ball ring, so that when squeezed together they hold the unit firmly at any desired angle.

Use Bakelite or other insulating material for the back cover and the baffle plate. Both pieces are held together with screws tapped into 2 brass spacers. Mount 2 pilot light bases, one on each side of the center hole in the baffle plate. The 2 red bulbs flash when the sensitive plate relay closes, a positive assurance that the driver is on the beam. Mount the #922 photoelectric tube between 2 brass angles, making sure that the concave side of the sensitive plate in the glass tube faces the hole in the baffle plate (Fig. 2). If pos-

sible, have the whole unit chrome-plated.

Assemble the control circuit (Figs. 3, 8, 9, 10 and 11) on a piece of Masonite 7 in. long by 6 in. wide and 1/4 in. thick. Drill holes for the tube bases and mount all major pieces as shown in Fig. 8. The stepping relay used in this circuit has a rotating cam that makes contact when the coil is energized, and breaks contact the next time the coil is energized. The cam has 6 teeth, so by removing every other tooth (Fig. 3), the relay has to be energized 3 times to close the motor circuit, but only once to break it.

MATERIALS LIST—GARAGE DOOR OPENER

- 1 gear motor (MB5820S, 86 rpm, 110 volts, 1/20 hp ratio motors) Boston Gear Works, Inc., 106-A Brookline St., Boston, Massachusetts
- 1 piece of Masonite 10" x 7" x 1/4"
- 1 piece of tubing brass 3 1/2" long by 3" O.D.
- 1 piece of tubing brass 1 1/2" long by 3 1/2" O.D. 3" I.D.
- 1 lens (bull's eye) 3" dia. 3" focal length
- 1 single pole double throw (reversing) microswitch
- 1 single pole single throw (limit sw.) normally open microswitch
- 1 10 meg. 1/2 watt resistor
- 1 2.2 meg. 1/2 watt resistor
- 1 1 meg. 2 watt potentiometer
- 1 stepping relay, 110 volts ac, 200 ohms 210 mils. single pole single throw normally open S-120 code-A. Guardian Electric Mfg. Co., Inc., Dept. A, 1621 W. Walnut St., Chicago 12, Ill.
- 1 plate circuit relay, LM7 5000 ohms double pole single throw normally open, pull in 6 ma. drop out 4 ma. Potter & Braumfield Sales Co., Dept. R, 549 W. Washington Blvd., Chicago 6, Ill.
- 1 922 photoelectric tube
- 1 6BH6 tube and base
- 1 6H6 tube and base
- 1 6.3 v. 1 amp. transformer
- 1 .005 mfd. mica condenser
- 2 16 mfd. 150 v. electrolytic condensers
- 2 3 amp. fuses and holders
- 2 6.3 v. bulbs and bases
- 1 push button switch

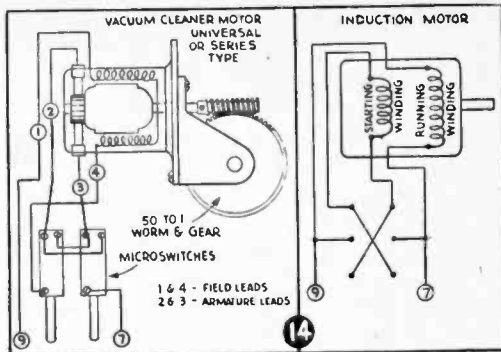
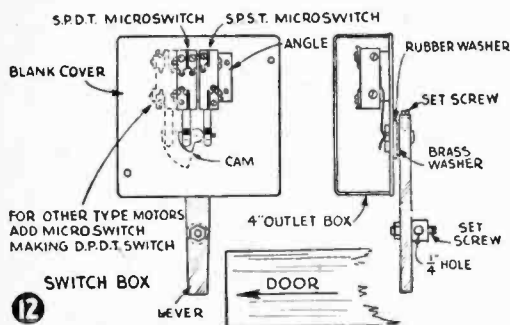

Fig. 15. Direct V-belt drive.



12

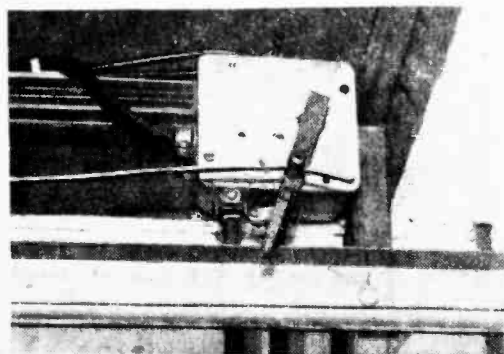

Fig. 13. Switch box stops and reverses motor.

Details on the switchbox and its mounting are shown in Figs. 12 and 13. The motor used in this door opener is a small 50 rpm gear motor requiring only three leads to reverse it. (Almost any motor can be used by adding another microswitch, and connecting it up as shown in Fig. 14.) The mounting of the motor, V-belt drive pulley and cable connections to the garage door are shown in Figs. 4, 5, 15, 16 and 17. Fig. 5 shows the relationship of the switch wiring to the door action.

After the control circuit has been wired, plug it in and allow a few minutes for it to warm up. Then adjust the sensitive plate relay by turning the potentiometer.

Place the photocell unit in the garage wall close to (but not on) the door, and out of the direct rays of the sun, making sure that it is in direct line with the beam on your headlight, or your spotlight if you have one (Fig. 2). To get the right location, drive the car within 10 ft. or so from the wall. Turn on the headlights and mark a cross where the beam shows strongest. On the same level as the cross mark, sound the wall with a hammer until a hollow sound indicates a

More Ideas To Build Useful Things

Here are some of our most popular projects. Each craft print gives complete dimensions and all necessary construction details. You'll enjoy making these projects. Order by number.

SPECIAL DISCOUNT: If your order is for 2 or more plans, you may deduct 10c per plan from the price listed. 2 plans deduct 20c, 3 plans deduct 30c, 4 plans 40c, etc. Order several and save.



- 1—WALL SHELF
Oak leaf design jig-saw job. .50c
- 4—MOTOR SCOOTER
Made from used parts.50c
- 16—"SANTA MARIA"
Model of Columbus' flagship
(3 large sheets)1.00
- 17—CIRCUS WAGON
Model for your "Big Top" . . .50c
- 19—M. G. ENGLISH SPORT CAR
1/4" scale model this popular
car50c
- 23—STATION WAGON
Model of 1850 English Rig. .50c
- 25—SPEED KING
Steam powered model boat—
plans include instructions for
building steam engine.50c
- 26—SCROLLED WALL BRACKET
Grape leaf pattern. Attractive. .50c
- 28—CURTISS HAWK
Control line model of fast bi-
plane50c
- 29—"STAR DUSTER"
Model motor sailer.50c
- 34—O-GAGE ELECTRIC LOCOMO-
TIVE
Model project for young and
old75c
- 37—A BREEZE
36" Maroon Rig model sloop. .50c
- 40—BLUE FALCON
Model high speed auto racer
for class "A" motors.50c
- 43—CANVAS KAYAK
A boat Junior can build.50c
- 45—TALLY-HO MODEL COACH
Authentic model of early Eng-
lish road coach.75c
- 51—DIRT TRACK RACER
How to build a hot-rod racer. .50c
- 68—GARDEN WINDMILL
Patterned after old Dutch wind-
mills. Brightens any garden. .50c
- 83—3-in-1 WALL SHELF
5 Jigsaw shelves from 1 plan. .50c
- 84—FOLDING LAWN CHAIR
Comfortable, easy to build. .50c
- 89—CABIN TRAILER
12-ft. plywood construction. .50c
- 118—LAWN ORNAMENTS
Patterns for 11 birds and
animals50c
- 118-A—LAWN ORNAMENTS
Patterns for 7 garden figures. .50c
- 145—WIG-WAGGING TURTLE
Action toy that thrills kiddies. .50c
- 146—WADDLING DUCK
Children love this toy.50c
- 151—ELECTRON 111
29-in. motor powered remote
controlled cabin cruiser.50c
- 156—POLE WAGON
Circus wagon for your "BIG
TOP"50c
- 158—1903 MODEL FORD
1/4" scale model.50c
- 166—WINCHESTER 73
Model rifle.50c

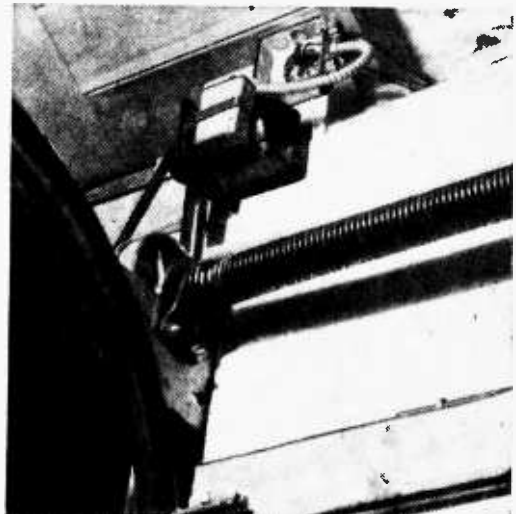
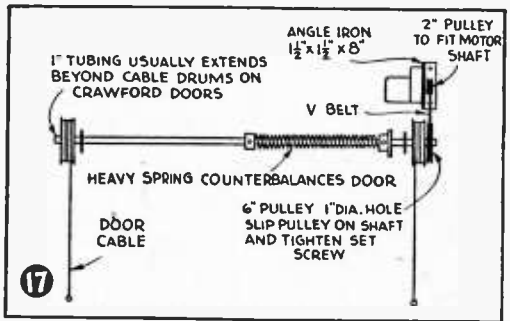

Fig. 16. Motor mounted directly above cable drum.



spot between the studs. Scribe a 5 in. circle and cut through the clapboards with a curved chisel. Next scribe a 3 3/4 in. dia. circle, bore a hole near the edge and cut out with a keyhole saw. The unit will fit into the outside wall where it is protected from the weather (Figs. 1 and 2).

The potentiometer adjusts the sensitivity of the photo cell, and ordinary line voltage fluctuations can be taken care of by making the unit less sensitive. Make your final adjustment on a bright sunny day, and adjust the potentiometer so that the plate relay does not close in the brightest sunlight, drive the car within 10 ft. or so from the cell, and try your headlights. If the relay fails to work, try reversing the line connections, for the circuit will work only one way. The wire from the cathode of the photocell cannot run close to any ac line unless it is shielded and the shield grounded to a point between the two 16 mfd. condensers. The unit should use less than 10 watts.

If your garage is so located that there is a chance that headlights from passing cars might strike the photocell unit, perhaps you can design a cover for it, to be used when you do not intend using the car.

—USE THIS HANDY COUPON—

SCIENCE AND MECHANICS MAGAZINE
450 East Ohio Street, Dept. R-552, Chicago 11, Ill.

Enclosed is \$..... for which send me Craft Prints

Nos.

NAME

ADDRESS

CITY, ZONE, STATE

(Sorry, No C.O.D.'s. Money back guarantee)

Plug-in Atom Bomb Radiation Alarm

You can use this Geiger counter, which signals presence of radioactive waves, through your radio loudspeaker for testing after A-bomb attacks

By
THOMAS A. BLANCHARD

THIS radiation detector (Fig. 1) plugs into the average home radio and records radioactive waves as a "dot and dash" kind of warning through the loudspeaker. You can attach the adapter (Fig. 2) to your set simply by pulling out audio output tube, inserting adapter plug in the tube socket, then replacing output tube into socket provided on adapter plug (Fig. 5). With this simple change, your set is equipped to record the presence of radioactions. And you can also use it with a small, portable battery set by adding a self-contained power supply shown in Fig. 6.

The Geiger counter tube used is a simple 2-element unit consisting of a cathode and anode across a high voltage supply. Just as a photoelectric cell allows a small current to flow through it when exposed to light, a similar effect takes place when a Geiger tube is exposed to radioactive waves. But whereas the photo-cell requires not more than 90 v. to excite it, the Geiger counter tube requires a much higher

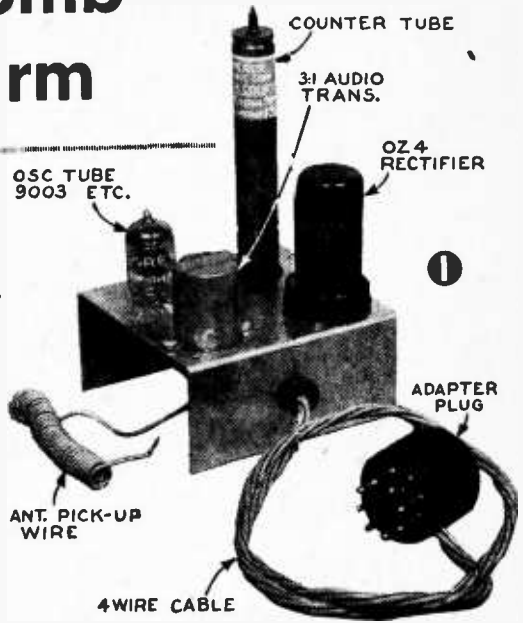

Radiation detector operates off radio set power, sends signal via radio loudspeaker. Midget audio transformer may be replaced with standard size.

MATERIALS LIST—RADIATION DETECTOR

- 1 Alum. 1½ x 3 x 3½" chassis (optional—parts may be mounted on wood baseboard, etc.)
- 1 Amperex counter tube #75NB3 (Amperex Electronic Corp., Dept. 4, P. O. Box 418, Hicksville, L. I., New York.)
- 1 OZ4 or OZ4A cold cathode rectifier tube
- 1 Pentode type tube (used as oscillator) 9003, 6AK6, or 50B5
- 1 Audio transformer. 3:1 ratio (Stancor miniature #354A2, or Stancor #A53C)
- 1 1.8 or 2 megohm, ½ watt resistor
- 1 Octal wafer socket, etc., for OZ4
- 1 7-pin miniature wafer socket for 9003, etc.
- 1 3-pin Amphenol socket #78-S33 for counter tube
- 1 Amphenol octal socket #78RS3 for adapter plug
- 1 Octal GT size tube base for adapter plug
- 1 SPST toggle "On-Off" switch
- 1 .005 mfd. paper capacitor, 600 w.v.
- Misc. mtg. screws, nuts, hook-up wire and cable.
- Self-Contained Power Supply (if desired)
- 2 50 to 100 ma. selenium rectifiers
- 3 20 mfd. 450 w.v. electrolytic condensers
- 1 4.7 or 5 ohm, 1 watt resistor
- 1 180 to 270 ohm, 5 watt resistor
- 1 400 ohm, 10 to 20 watt wire-wound resistor
- 1 SPST toggle switch

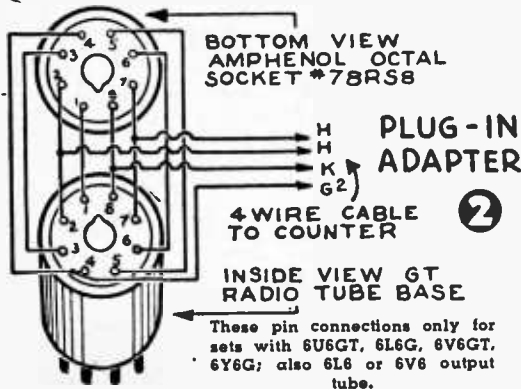

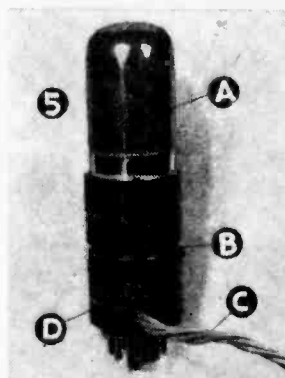
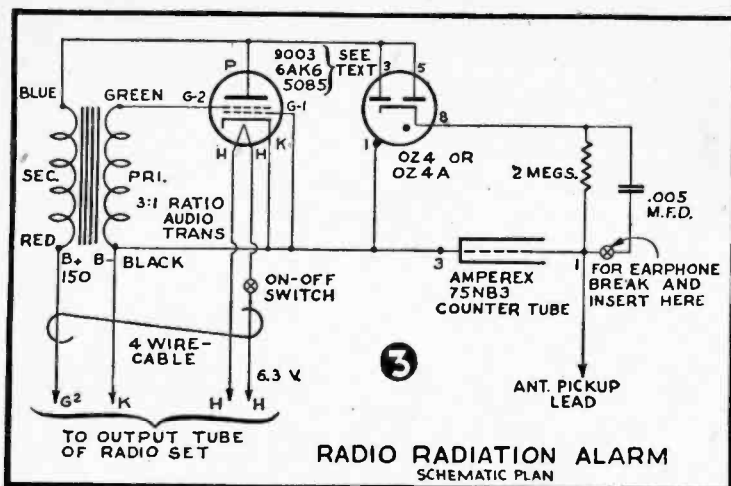

Close-up of adapter. (A) Radio output tube; (B) Amphenol 78RS8 socket; (C) wires to radiation counter tube; (D) octal GT tube base.

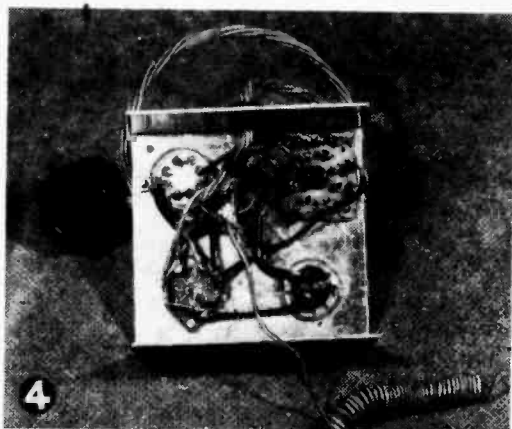

Bottom view of plug-in radiation alarm. Only standard radio parts are used to build it.

potential, anywhere from 300 to 900 v., depending on the particular tube. The few tubes operating at 300 v. are limited both in scope and life span. Higher voltage tubes, in particular those with unlimited life such as the Amperex 75NB3, are recommended.

To obtain the 700 v. potential required to activate the tube, we use here a "flea-power" version of the *flyback* circuit employed in TV receivers, where a single 6BG6G oscillator tube provides the picture tube's second anode with voltages ranging from 9" to 14 thousand volts. Our Amperex 75NB3 requires only 700 volts. To obtain this voltage a simple blocking oscillator consisting of a 3:1 ratio audio transformer and most any type pentode tube, does the trick!

Actually, this circuit is no different from those used for code practice sets. But, the high-voltage, low current output of the audio transformer is ample to operate a 700 volt counter tube. The signal which is in the order of 1200-1500 cycles is fed to the plates of an OZ4 or OZ4A cold-cathode rectifier. This is a gas-type

tube requiring no filament voltage. While designed to handle 300 volts maximum, it normally would carry a much larger current. By tying both plates together and using it as a half-wave rectifier, handling a minute current, it performs perfectly. The high frequency of the ac voltage developed by the oscillator (1500 as compared to 60 cycles from power lines) made filtering of rectified voltage unnecessary.

The audio transformer used in this detector was a Stancor #354A2 which is an ultra-miniature type and somewhat expensive. You should employ the "open-frame" type audio transformer such as the Stancor #A53C which costs about \$1.50. The center-tapped lead on this or other 3:1 audio transformers is not used. Miniature audios, with 4 primary and 4 secondary soldering lugs, should have the 2 center lugs on each side (primary and secondary) connected together to complete continuity.

Power to operate the oscillator can be derived from the radio set with which the radiation detector is used. That is the purpose of the adapter plug which consists of a Bakelite GT size base salvaged from a burned-out tube. After breaking glass and scraping out remaining glass and cement from inside tube base, apply a soldering iron to each base pin, and blow into Bakelite base to clear old solder and tube element wires. Drill a $\frac{1}{4}$ in. hole into side of base for 4-wire cable. An Amphenol octal socket type 78RS8 makes a tight friction fit inside GT-size tube base. First, however, connect 4-wire cable to cathode (K), screen grid (G-2), and heater (H) lugs of tube socket. Now cut eight 3 in. lengths of #22 tinned bare hook-wire and solder to all 8 lugs of tube socket. Thread free ends through tube base pin openings, push socket down tight into tube base, pull any surplus wire out the pin opening and cut off flush. Solder base pin tips so all 8 leads are secure.

This adapter applies only to tubes indicated in drawings. For other output tubes, refer to a

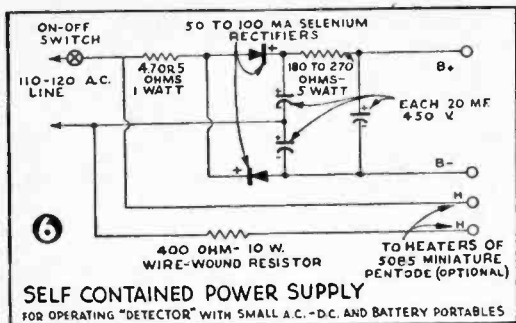

radio tube manual or tube base book available from your radio parts dealer (try the RCA Tube Manual). This adapter system is not, however, suitable for ac-dc and portable battery sets since there is only 60 to 90 v. available from screen grid connection of output tube. To operate detector in conjunction with such sets, a separate power supply is employed (Fig. 6). Note the voltage-doubler circuit with a 150-180 output using 2 inexpensive selenium rectifiers.

The oscillator tube employed in this detector is an inexpensive 9003 miniature type; it is also a type with a low current heater (150 ma.) so that added to the 6.3 v. filament string in set, the small additional load does no harm. Some sets have power transformers husky enough to handle an extra tube rated up to 400 ma. But it's best to use a 150 ma. tube to prevent over-

loading transformer. The 9003 may be replaced with miniature 6AK6. This tube has an additional grid (G-3), however. Tie G-3 to G-2 or P, whichever provides most satisfactory operation. The independent power supply (Fig. 6) shows a separate heater circuit which you may use with a miniature 50B5 tube as oscillator in your detector unit. Thus, all power required to operate the radiation detector may be obtained without use of plug-in adapters.

To operate this detector, turn on radio set with adapter plugged in. Also turn on independent power unit if one is used. Wind insulated antenna pickup lead from adapter around lead-in wire of set antenna, or place it anywhere near set—but don't connect it directly at any time. When set and detector have warmed up, you'll hear a steady high-pitched tone. Tune radio to point on dial where signal is strongest, and where no station comes in. Now, if you bring a radioactive ore sample or even a clock with a radiant dial near Geiger counter tube, you'll hear a series of sounds exactly like the dots and dashes heard on shortwave radios.

The steady tone signal shows the counter is working and the change from continuous tone to dots and dashes means radioactive waves are present. You don't have to disconnect the detector once it's installed. A toggle switch installed in heater circuit of 9003, 6AK6, or 50B5 oscillator tube will cut off the tone signal so your radio performs as usual.

Get This Valuable Book

FREE



Just for Examining COYNE'S New 6-Volume Set

"Applied Practical Radio-Television"

**ON 7 DAY
FREE
TRIAL!**

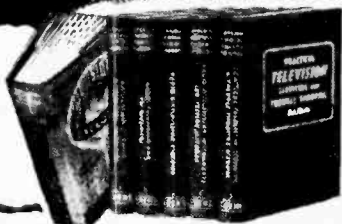

Yes, you get this big, brand new book, "150 Radio-Television Picture Patterns and Diagrams Explained", absolutely FREE! Just off the press! Gives complete wiring circuits and diagrams on the latest Radio and Television Sets. Easy-to-read, large 8 1/4 x 11" pages, with full instructions on how to read and use the diagrams. A "must" in every Radio and Television service-man's repair kit. You get this valuable book as a FREE Gift for asking to see Coyne's great new 6-book set, "Applied Practical Radio-Television!"

Here's "Know-How" That Makes You Worth More!

You'll get into the big money faster in TELEVISION-RADIO if you know where to find the answer to servicing problems. Coyne's great new 6-volume set gives you all the answers—quickly! For basic "know-how" that is easy to understand, you'll find everything you want in volumes 1 to 5 which contain over 5000 practical facts and data. They cover every step from principles to installing, servicing, trouble-shooting and aligning all types of radio and TV sets. So up-to-date it includes COLOR TV and UHF adapters and converters.

762-Page Television Cyclopedic Included

And then, for speedy on-the-job use, you get volume 6—the famous Coyne TELEVISION CYCLOPEDIA. It answers today's television problems on servicing, alignment, installation and others. In easy-to-find ABC order, cross indexed. Use this 6 volume TV-RADIO LIBRARY free for 7 days; get the valuable Servicing Book ABSOLUTELY FREE!

SEND NO MONEY! Just mail coupon for 6-volume set on 7 days free trial. We'll include book of 150 TV-Radio Patterns & Diagrams. If you keep the set, pay \$3 in 7 days and \$3 per month until \$23.00 plus postage is paid. (Cash price \$22.00). Or you can return the library at our expense in 7 days and owe nothing. **YOU BE THE JUDGE.** Either way, the book of TV-Radio Patterns is yours FREE to keep! Offer is limited. Act NOW!

FREE BOOK—FREE TRIAL COUPON!

COYNE ELECTRICAL & TELEVISION-RADIO SCHOOL, Dept. 92-RE
500 S. Paulina St., Chicago 12, Ill.

YES! Send 6-volume "Applied Practical Radio-Television" for 7 days FREE TRIAL per your offer. Include TV-Radio Patterns & Diagram Book FREE.

Name..... Age.....

Address.....

City..... Zone..... State.....

Where Employed.....

Check here if you want library sent COD. You pay postman \$22 plus COD postage on delivery. 7-day money-back guarantee.

COYNE ELECTRICAL & TELEVISION-RADIO SCHOOL
500 S. Paulina St., Dept. 92-RE Chicago 12, Ill.

**S & M
Data
Sheet**

Portable Radio and Hearing Aid Batteries

By HAROLD P. STRAND

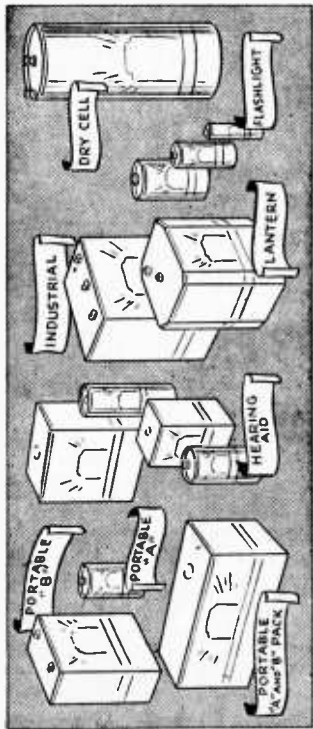

PORTABLE RADIO "A" BATTERIES

Burgess	Eveready	Ray-O-Vac	Volts	Size*
2R	850	2LP	1½	2½x1½x 1/8" dia.
2F	742	P24A	1½	2½x1½x 4/8"
4F	742	P84A	1½	4½x2½x 2½"
4FL	743	P94L	1½	37/64x1 1/8x 51/8"
8F	741	P88A	1½	4½x2½x 4 1/8"
8FL	745	P88A	1½	3¾x2¾x 5 1/8"
G3	746	P83A	1½	3¾x11/8x1011/8"
F4PI	744	P894A	4½	4 x1½x 4 1/8"
F4PIX	—	—	6	2½x2 5/8x 4"
F4L	—	P894L	6	2½x2½x 4 1/8"
FX	—	—	6	4 x1½x 8 1/8"
2F4	717	P888A	1½	4½x2½x 4 1/8"
2F4L	747	P888L	6	3¾x211/8x 5 1/8"
G5	887	P85A	7½	3¾x1 7/8x1011/8"
T5	—	—	7½	3¾x211/8x 4 1/8"
	—	—	7½	21/8x21/8x 3 3/8"

Above "A" batteries for portable radios require special adapter plugs of various types as found on radio lead wires. Three makes of batteries are listed, with comparable type numbers, so that a choice can be made.

*Dimensions are taken from Burgess data sheets, but the other makes are quite close in size. They are electrically the same and usually can be interchanged.

PORTABLE RADIO "B" BATTERIES

Burgess	Eveready	Ray-O-Vac	Volts	Size
K20	—	—	30	1½x 1 1/8x2 3/8"
W20PI	—	—	30	1 1/8x1 1/8x4 1/8"

Burgess	Eveready	Ray-O-Vac	General Dry	Volts	Size
XX16E	428P	PN16	901	22½	11½x 1 1/8x3 7/8"
XX22E	433P	PN22	902	33	21½x 1 1/8x3 3/8"
XX30E	455P	PN30F	903	45	21½x 1 1/8x4 1/8"
K10E	417E	—	—	15	7 1/8x1 1/8x1 1/8"
K15E	420E	—	—	22½	7 1/8x1 1/8x2 1/8"
K20E	430E	—	—	30	5 1/8x1 1/8x2 1/8"
U10E	411E	—	15	15	1 1/8x 1/8x 1 1/8"
U16E	412E	—	22	22½	1 1/8x 1/8x 1 1/8"
U20E	413E	—	30	30	2 1/8x 1/8x 1 1/8"
T2R	142	—	EP135	3	1 1/8x211/8x4 1/8"
T3R	165	—	EP131	4½	1 1/8x3 1/8x4 1/8"
T2WE	130	WE141	EP269	3	1 1/8x211/8x4 1/8"
T3WE	145	WE161	EP270	4½	1 1/8x211/8x4 1/8"
C3WE	—	—	—	4½	1 1/8x3 1/8x2 1/8"

In the Burgess listing, the first group is "A" batteries, all of 1½ volts, but of varying dimensions. XX series consists of general purpose "B" batteries of economy size. The K and U series batteries are "B"s for self-contained hearing aids and are of comparatively small size. T batteries and the C3WE type are for carbon hearing aids.

In general, the same type of batteries should be used for replacements as the original equipment. If no batteries are included with the hearing aid when you receive it, contact the manufacturer or his accredited agent to obtain correct battery model numbers and refer to the list above. Some manufacturers of hearing aids have their own batteries with special model numbers, but Burgess and Eveready usually have replacement batteries.

IGNITION—TELEPHONE—LANTERN—DOOR BELL BATTERIES

Burgess	Eveready	Ray-O-Vac	General	Volts	Size (Burgess)
4FH	No. 6	94IS	4FTS	1½	4½x2½x2 1/8"
4F2H	—	88T	—	3	5 1/8x3 1/8x2 1/8"
4F3H	—	—	—	4½	5 1/8x3 1/8x3 1/8"
4F4H	1461-2	641 or B	641-2	6	8 1/8x8 1/8x2 1/8"
4F5H	1562	651B	651	7½	8 1/8x7 1/8x4"
4F6H	1662	661B	662	8	8 1/8x8 1/8x4"
F4H	(lantern) 409	941	V4F	6	2 1/8x2 1/8x3 1/8"

The four makes listed above have comparable type numbers, but size refers to the Burgess make because only the electrical comparison has been made in this case. Where space is not a factor, this is of little importance. As an example, the No. 6 dry cell of Eveready is round, about 2 1/8" in. dia. and 6 in. high, and it delivers 1½ volts. The Burgess 4FH square battery could be substituted since it also delivers 1½ volts, and takes up less space.

FLASHLIGHT BATTERIES

Burgess	Bright Star	Eveready	Ray-O-Vac	General	Volts	Size
1	111M	835	1	C	1½	1 1/8x1" dia.
2	7 & 10M	950	2LP	D	1½	2 1/8x1 1/8" dia.

Z	59-1	915	7R	AA	1 1/2	1 1/4 x 3/8"
	1917M		121	C2	3	3 3/4 x 1 1/2" dia.
					3	3 1/2 x 3/4" dia.
	90-17M	790	221	D2	3	4 3/4 x 1 1/2" dia.
	05-17M	705	231	D3	4 1/2	7 1/2 x 1 1/2" dia.
					3	2 1/4 x 1 1/4 x 1 1/4"
	50-17	750	421	2A	4 1/2	2 1/4 x 2 x 1 1/4"
	51-17	751	531	H3AF	4 1/2	2 5/8 x 2 1/4 x 1 1/4"
	03-17	703	431	H3BF	4 1/2	

Batteries may be either one cell or made up in a cardboard container which contains 2 or 3 cells. For example, the first 3 types listed are 1 cell and give 1 1/2 volts. The next 3 batteries contain 2 cells in series and therefore give 3 volts. The next one has 3 cells and delivers 1 1/2 x 3 or 4 1/2 volts. This group is of the round type.

The last 3 batteries are of the flat type and contain either 2 or 3 cells, as indicated by the voltage.

Batteries listed in this data sheet may be purchased at your local radio and electrical stores from mail order radio supply houses, or from the manufacturers: Burgess—The Burgess Battery Co., Dept. 651, Freeport, Ill.; Eveready—National Carbon Co., 312 Eveready Div., 30 E. 42nd St., New York, N. Y.; Ray-O-Vac—Ray-O-Vac, 2328 Winnago, Fourth Fl., Madison, Wis.; General—General Dry Batteries, Inc., 13000 Athens Ave., Rm. 832, Cleveland, Ohio; Bright Star—Bright Star Battery Co., Dept. SM, Clifton, N. J.

SINGLE CELLS OR BATTERIES CAN BE CONNECTED TO INCREASE VOLTAGE OR CURRENT

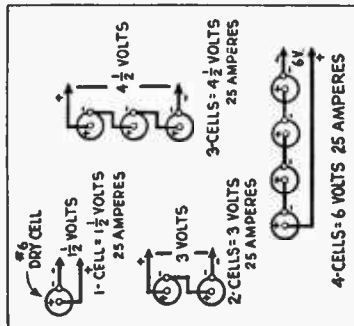

SERIES CONNECTIONS OF SINGLE DRY CELLS
Voltage of 1-Cell X Number of Cells = Voltage of Group. Current Remains Amperage of 1-Cell.

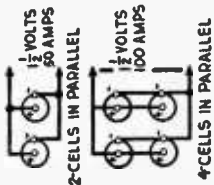

PARALLEL CONNECTIONS
Voltage Remains that of 1-Cell. Current of 1-Cell X Number of Cells = Amperage of Group.

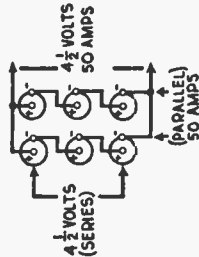

6-CELLS IN SERIES-PARALLEL
SERIES-PARALLEL CONNECTIONS
Voltage of 1-Cell X Number in Series = Voltage of Group.
Current of 1-Cell X Number in Parallel = Amperage of Group.

A30		45	3 1/2 x 2 1/4 x 4 1/2"
A30M		45	3 1/2 x 2 1/4 x 4 1/2"
B30		45	4 1/2 x 2 1/4 x 4 1/2"
Z30		45	3 1/2 x 2 1/4 x 4 1/2"
M30		45	3 1/2 x 1 1/2 x 4 1/2"
W30P1		45	3 x 1 1/2 x 4 1/2"
XX45		67 1/2	2 1/2 x 1 1/2 x 3 3/4"
Z59		88 1/2	3 5/8 x 2 1/2 x 5 1/2"
A60		90	4 1/4 x 3 1/4 x 4 1/4"
XX30		455	2 1/2 x 1 1/2 x 3 3/4"

Above portable radio "A" batteries take special adapter plugs, as required by individual radios. Compatible model numbers are given for 3 makes whose dimensions and electrical characteristics are similar.

PORTABLE RADIO BATTERIES "A" AND "B" PACKS

Burgess	General	Ray-O-Vac	Volts	Size	Plug
2TX40	40C-W2CF		1 1/2	2 1/2 x 1 1/2 x 7 1/2"	
F6A60P			9	9 3/4 x 2 1/2 x 4 1/4"	2768
D4B50		AB685	6	12 1/2 x 2 1/2 x 4 1/4"	M64
D4A60			6	5 1/2 x 2 1/2 x 7"	2745
4GA41			1 1/2	1 1/2 x 8 1/2 x 9 1/2"	2791
2FA460		AB-694	6	4 1/2 x 2 1/2 x 11 1/2"	2900
F5A60			7 1/2	4 1/2 x 2 1/2 x 11 1/2"	
G6B60		AB995	9	4 1/2 x 2 1/2 x 13 1/2"	2908
3FA60		60A4F1	6	4 1/2 x 2 1/2 x 10 1/2"	120
G5A42		AB-794	7 1/2	4 1/2 x 2 1/2 x 9 1/2"	2900
F5M45		AB767	7 1/2	4 1/2 x 2 1/2 x 9 1/2"	
G6M60		AB878	9	4 1/2 x 2 1/2 x 10 1/2"	
4GA42		AB419	1 1/2	4 1/2 x 2 x 9"	2745
5DA60			1 1/2	5 1/2 x 2 1/2 x 8 1/2"	120
6TA60			1 1/2	4 1/2 x 2 1/2 x 9 1/2"	
4FA60			1 1/2	4 1/2 x 3 1/2 x 7"	5705
F4B60			6	5 x 2 1/2 x 10 1/2"	2778
2FA860		10896	5	4 1/2 x 4 1/2 x 10 1/2"	M64
4TA60		10793	6	4 1/2 x 2 1/2 x 8 1/2"	120
LF460		AB84	6 1/2	6 1/4 x 1 1/2 x 11 1/2"	2745
F4A41		AB648	6	4 1/2 x 2 1/2 x 9 1/2"	M64
F6A60		AB994	9	4 1/2 x 2 1/2 x 9 1/2"	

Above combination "A" and "B" battery packs, designed for portable radios, use adapter plugs as specified. Burgess complete model numbers are given, together with 2 other makes with model numbers that will usually replace them. Dimensions given may vary a little with different makes.

In addition to those mentioned above, special "A," "B," and "C" batteries are available for farm use.

HEARING AID BATTERIES

Burgess	Eveready	Ray-O-Vac	General Dry	Volts	Size
1ES	1035	1LP	828	1 1/2	1 1/2 x 1 1/2" dia.
2ES	1150	2LP	828	1 1/2	2 3/4 x 1 1/2" dia.
TE	1052P-1005E	PF-1	728	1 1/2	2 3/4 x 1 1/2" dia.
5ES			900	1 1/2	1 1/2 x 1 1/2 x 1 1/2"
2ZE	1018E		20	1 1/2	1 1/2 x 1 1/2 x 1 1/2"
CL	1040		925	1 1/2	1 1/2 x 1 1/2 x 2 1/2"

Fun with a One-Tube ELECTRONIC ORGAN

THIS novel electronic organ employs a simple tuned oscillator circuit, much like that employed in elaborate electronic instruments. However, where the real organ uses many individual oscillators as well as mechanical devices for its effects, the little organ described here limits its scope to a simple one-tube circuit. Yet with its simplicity and limitations, this organ produces musical effects ranging from tuba-to fife-like tones. In the middle ranges, it sounds much like any reed type organ. The organ keyboard consists of 20 chromatic notes. These may be played in a choice of four ranges from treble to bass. The tap-switch on the keyboard functions much like the "stops" on a conventional organ.

The heart of the instrument is the oscillator. A small metal chassis 3¾ in. long, 3¼ in. wide, and 1½ in. high is made to general design shown in illustrations. However, oscillator can be wired up on a wooden base, if desired. Our pictorial wiring plans show oscillator details so that assembly may be left to individual choice. The oscillator employs a type 117L7/M7GT tube. This tube is really two tubes in one glass envelope: a power pentode and a half-wave rectifier. And since it has a 117 volt filament, no resistor or transformer is needed to lower "heater" voltage.



Completed electronic organ consists of: left, 20-key console with control providing 4 tone ranges; center, 5 in. PM speaker; and right, 1-tube oscillator.

It plays tunes with tone effects ranging from a reed organ to a bass tuba

By THOMAS A. BLANCHARD

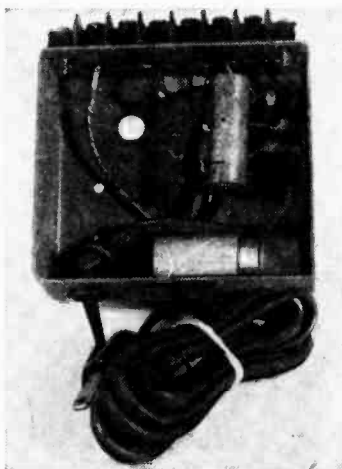

Bottom view of oscillator-amplifier which is heart of organ. Lower right, 20 mf. condenser; center, .05 mf. condenser, with tube socket below it. Tube and input transformer are located on top of chassis.

The 117L7/M7GT contributes much to the circuit's simplicity.

A 6-post terminal strip on front of chassis provides means for connecting PM speaker, keyboard, and range control. Since the oscillator is a complete assembly in itself, overall construction of organ is greatly simplified. After obtaining components given in materials list, wire according to picture plan.

With the oscillator completed, test it by connecting a .00035 mfd. fixed mica condenser across terminals #1 and 2. Then attach a 470,000 ohm, ½ watt resistor across terminals #3 and 4. Finally attach a PM speaker, (through a matching PM output transformer) to terminals #5 and 6. Plug cord into power line and allow oscillator to warm up. After warming up, oscillator should produce a high whistle. If not, check wiring carefully. If everything is in order, reverse primary connections of 3:1 ratio audio input transformer. This will place primary and secondary polarity in proper relation and unit will then oscillate.

Now if the 470,000 ohm resistor is replaced

BOOKS TO HELP YOU

● On pages 190 and 191 you will find a list of the latest books on radio and television. Whether it's for pleasure or profit, hobby or business, these books will

guide you in answering your every radio and television question. A handy coupon makes it easy to order the books of your choice.

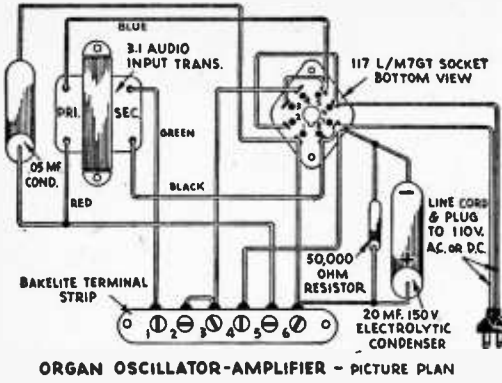

ORGAN OSCILLATOR-AMPLIFIER - PICTURE PLAN

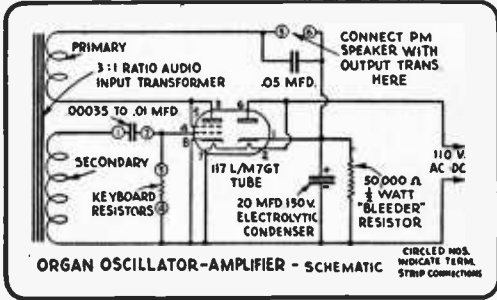

ORGAN OSCILLATOR-AMPLIFIER - SCHEMATIC

with a somewhat higher value, a different tone will be heard. Therefore, since each change in grid return resistance produces a different tone, a string of resistors, each with a "tuned" value, will reproduce all tones in the musical scale. The keyboard, therefore, is actually nothing but a series of switches—each black and white key closing the circuit along a series resistance network, and causing a different resistance to be placed between grid and ground of oscillator tube.

To save time, you can use well-seasoned white pine Xylophone keyboard (see drawings) in place of piano-type keyboard. Use only dry material unless you want organ to be out of tune or worse! Arrange 20 nickled or brass thumbtacks in the manner shown. Under each tack secure resistor leads. It is very important that all connections are solid! Inspect tacks to be sure they are not tarnish-proofed with clear lacquer. If so, soak them in acetone to remove this film. Be certain that keyboard resistors are exactly the values given in Table A, and that no open or poor connections exist anywhere between R1 and R20.

With Xylophone keyboard finished, solder length of wire to free end of R20. Connect this lead to terminal #3 on oscillator. Run another length of flexible insulated wire from terminal #4 to a radio test probe. With the .00035 mfd. condenser still across terminals #1 and 2, you are ready to go. Touch each tack head with the probe tip and you get an electronically-produced note corresponding to those given on the keyboard diagram. Now shut off oscillator and

change .00035 mfd. condenser to a larger value: .0006, .001 or .01 mfd. The .01 mfd. will produce very low tones; .0006 and .001 mid-ranges.

Now with a working knowledge of the gadget, you can build up a regular type keyboard, if you wish, entirely from scratch, or get a head-start by purchasing a 20-note toy piano for about \$3.00. In the latter case, remove bells or chimes and revise key actions into individual switches in the following manner. There is usually enough room inside the average toy piano to include oscillator and a small PM speaker, making the organ completely self contained. You'll find that key actions in most toy pianos, as well as real instruments, work on knife-edge pivot system (see "exploded" plan of keyboard). Base of keyboard consists of two pieces of well-seasoned 1/4 in. plywood.

Each of these pieces measure 12 in. long by 4 3/4 in. wide. Take one panel and rip-saw into two pieces making cut 2 3/4 in. from the edge to give you one panel 2 3/4 x 12 in. and another 2 x 12 in. With brads and glue, attach 2 3/4 x 12 in. panel to 12 x 4 3/4 in. sub-base. The knife-edge pivot strip is placed against edge of 2 3/4 in. panel, and sandwiched-in by the remaining strip of 12 x 2 in. plywood which is also glued and nailed to sub-base.

The knife-edge strip is a 12 in. length of 3/8 in. steel band such as is used to secure shipping containers. If you can't secure one, use a 12 in. hacksaw blade or have a tinsmith cut a strip of 20 gage sheet metal to 12 x 3/8 in. Next cut out

TABLE A—KEYBOARD RESISTORS

(All resistors 1/2 watt size and 5% or 10% accuracy. A silver band on resistor is 10% grade. Gold band, 5% grade.)

R1 and R2....	88,000 ohms	R11	39,000 ohms
R3, R4, R5....	56,000 ohms	R12, R13, R14.	33,000 ohms
R6	88,000 ohms	R15, R16, R17.	27,000 ohms
R7	47,000 ohms	R18, R19	22,000 ohms
R8, R9, R10 &		R20	470,000 ohms

These resistors are STANDARD RMA values and not "freak" components.

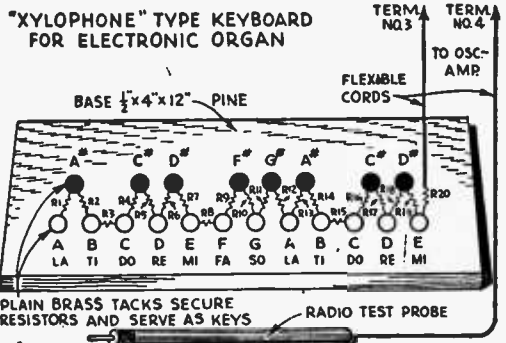

PLAIN BRASS TACKS SECURE RESISTORS AND SERVE AS KEYS RADIO TEST PROBE

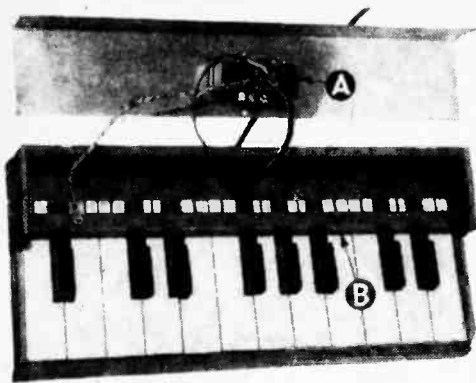

Console with aluminum cover removed. Note condensers and tone switch (A); position of contact bar (B). Keys slip under safety pin springs. Depressing key causes pin to raise and contact bar.

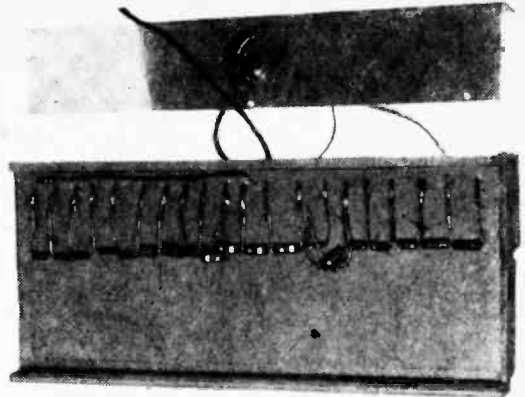

Bottom of keyboard showing resistors R1 to R20 soldered to projecting ends of safety-pin springs.

keys to dimensions on a jig saw. Use as narrow a saw blade as possible to slot each key on the underside to a depth of $\frac{1}{16}$ in. Now arrange keys on base according to positions shown in photos. You'll find the individually-notched keys will ride on the steel edge in teeter-board fashion.

With all keys in place, draw a line across rear of base $\frac{1}{16}$ in. in from edge. At center of each key position, make a centermark on parallel guide line. Do this manually as plotting off fixed spaces will possibly result in key-springs falling in the wrong position. Obtain two cards of #2 safety pins (20 pins) and with diagonal wire-cutting pliers, clip off clasp from each. Now, at each of the 20 marks along previously plotted parallel line, drill a hole (slightly smaller than

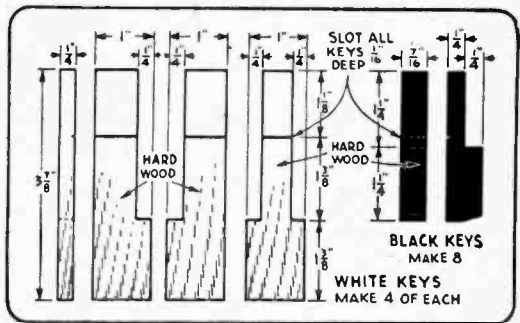

spring so that it falls in center of respective key. Now turn keyboard over and wire in the 20 resistors as shown. Projecting portions of springs serve as soldering lugs.

Finish the console with front, side and rear panels tacked and glued as shown. Now cut a strip of wood 12 in. long, $\frac{3}{4}$ in. high, and $\frac{3}{8}$ in. thick for the contact bar. To the $\frac{3}{8}$ in. side fasten a strip of brass, aluminum, or tinplate with several brads. At a point where it won't interfere with the key action, solder length of insulated wire, or mount a soldering lug as shown. Set this bar, metal-faced side down, into the console. Position it as close to springs as possible, but

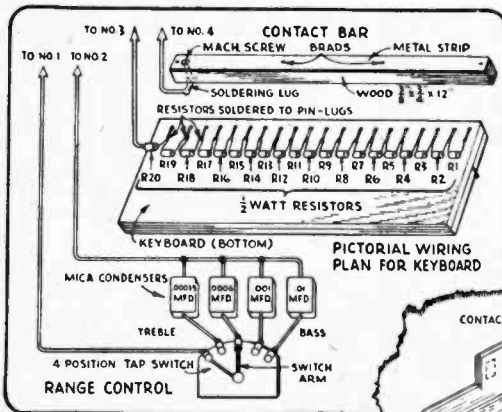

safety pin) through keyboard base. Now push a spring through each hole. Bend projecting portion of pin on underside of base down (see cross-section view in plans). With all safety pin springs in place, raise each one up and slide proper key in place. When key is depressed, it will now spring back. Align and adjust each

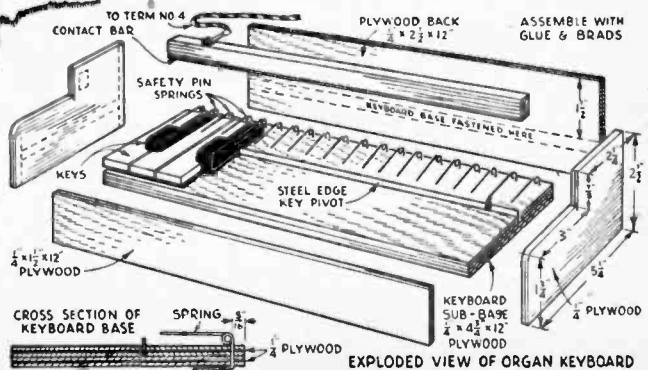

Soldering Iron Rest

- A short, narrow strip of sheet metal can be quickly made up into a convenient holder for the soldering iron by drilling a large hole near the soldering iron by drilling a large hole near

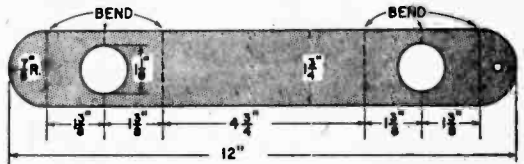
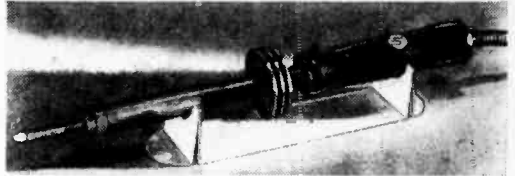

Keyboard base ready for keys. Lift spring and slide key under so slot (B) pivots on steel strip shown at (A).

without actually touching them. Now fasten bar securely at each end of console with small wood screws. As each key is pressed, lever action causes individual spring to raise and contact the bar. This closes circuit and sounds that particular note. Springs may be individually adjusted by careful bending with flatnose pliers.

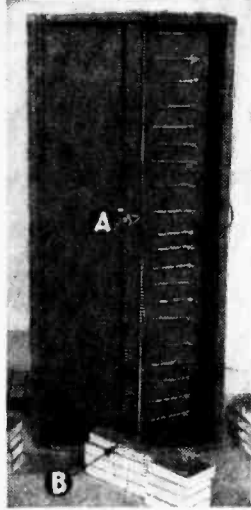

A metal cover consisting of a piece of light aluminum conceals the actions and provides a mounting for the 4-position tap switch and mica condensers which make up the range control. By notching end panels of console as shown, cover front slips into these slots and requires only three small screws across rear top edge to secure it.

Since this organ employs but a single oscillator, it is necessary to strike only one key at a time. The natural limitations of the circuit do not permit the playing of chords.

However, a little practice with the device will result in rapid fingering that is not possible with any instrument other than those of electronic nature. The novel effects greatly offset its shortcomings.

each end and bending to shape. First cut the strip to length, round the ends and drill the two large holes in each end. Bend the ends over at the exact center of each hole. Insert the piece between jaws of a vise a depth of 1 3/8 in. from the folded ends and bend both projecting pieces horizontal.—C. W. WOODSON.

First Aid for Little Speakers

- Speakers on inexpensive small radios can often be given a new lease on life with a little fingernail polish applied around the center of the cone. The fuzziness of sound may be cut down by stuffing a bit of Kleenex or tissue paper between the cone and the speaker arms.—ROBERT LEE NIELSEN.

Surplus Control Box Becomes Multimeter Case

By HENRY ZAVE

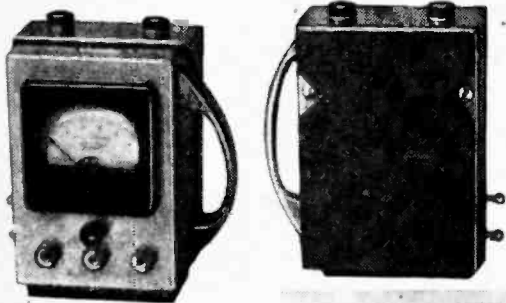

equipment, since they are generally made of strong die cast aluminum or magnesium alloys.

The multimeter illustrated uses a typical standard circuit with the usual multipliers and shunts. Pieces of thick felt are cemented to the back and one end so that the unit may be placed in the most readable position. Note that two triangular cuts in the felt on the back allow easy

removal of the screws which serve to hold the case cover on. At first glance the handle shown may seem unnecessary on so small an instrument, but it will be found to be a great convenience since it helps to prevent inadvertent damage to the instrument by providing a definite place to grip it.

MANY radio constructors have purchased surplus jack and control boxes in order to obtain the parts in this equipment. It will be found that these boxes make excellent cases for multimeters and other similar

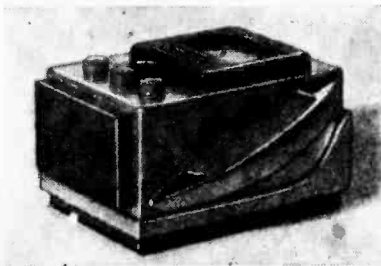

Three views of control box case with multimeter installed.

Putting 'Electric Eyes' to Work

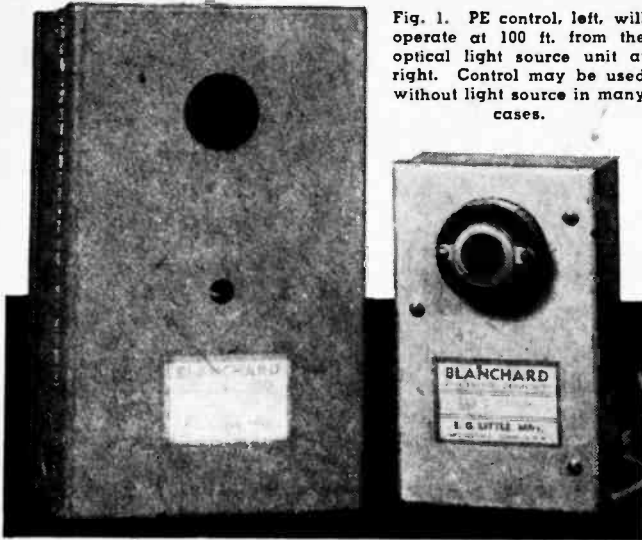

Fig. 1. PE control, left, will operate at 100 ft. from the optical light source unit at right. Control may be used without light source in many cases.

or automatic feed controls (Fig. 2).

Units exactly like the control shown here are working day in and day out. In one plant making medical supplies, several controls *exactly* like the one in Fig. 2A have been running 4 years without breakdown. In this instance, the production machines apply small medicated cotton pads and starch-gauze packing at uniform spaces on a mill roll of adhesive tape. The tape passes along to a die-cutter which stamps out the individual first-aid bandage you find inside the small glassine wrapper.

The problem, prior to installing the PE controls, was to keep the tenacious adhesive tape moving without having to unwind it manually from the mill roll. Pulling the sticky tape free was by far the operator's most difficult task. It also cut production way down. Production was doubled

MOST people think of photo-electric controls as burglar alarms or gadgets to automatically open garage doors. While these applications are possible, neither—believe it or not—have ever been very practical. But, there are scores of home and industrial uses for PE (photo-electric) controls where consistent and reliable results can be expected, such applications as fire detectors, store signals and liquid level

when photo-electric controls were installed. A flat wooden pulley covered with abrasive cloth was placed just ahead of the mill roll of adhesive tape. The pulley was driven by a 1/4 hp motor which in turn, operated off the PE control.

Enough space on the machine was left between the abrasive pulley and the pad applicator for mounting the PE control and light source shown in Fig. 2A. When the machine was started, light

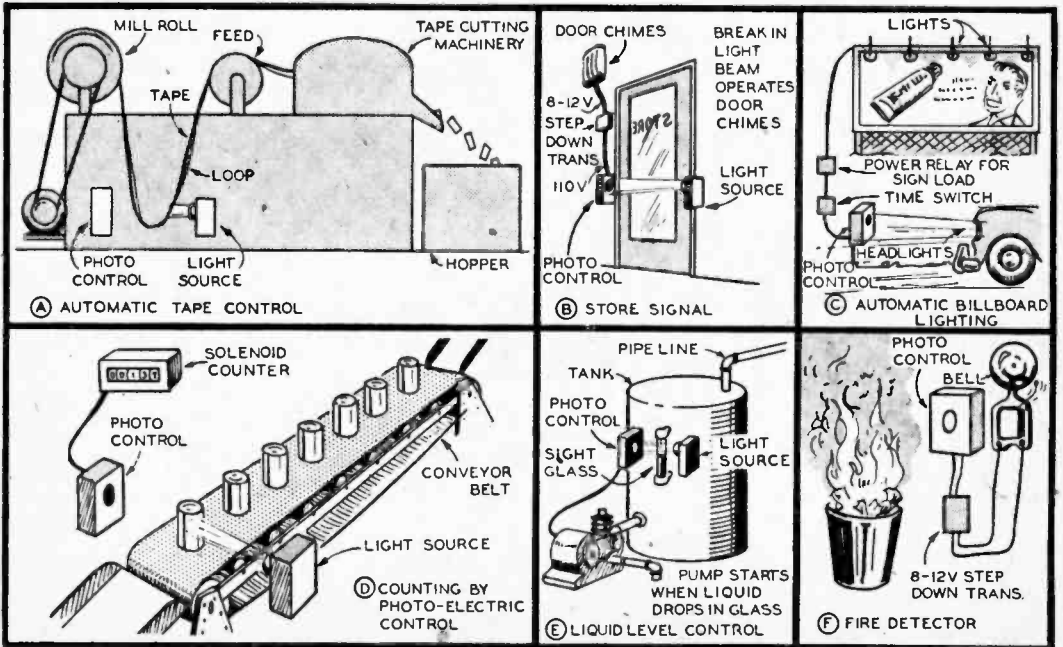

Fig. 2. Practical applications for photo-electric controls.

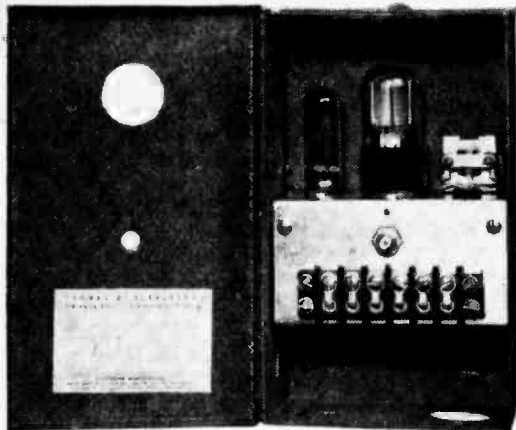

Fig. 3. PE control is housed in standard UL box allowing for permanent installation according to code rules.

struck the photo-electric tube; the 1/4 hp. motor turned the abrasive pulley which unwound the tape—pulling the smooth side—until it dropped down, in loop fashion, and cut off the light between photo tube and light source. The tape roll then remained stationary until the machine applying the pads consumed the existing supply of loose tape. As soon as the loop of tape again shortened to expose the light to PE control, the abrasive pulley again unwound more tape, etc.

Controls of this simple PE type are ideal for counting or rejecting cans, boxes, bottles, etc. coming off a conveyor belt (Fig. 2D). Instead of a motor connected to terminals #5 & #6 (Fig. 5), a solenoid counter or "kick" would be attached. Solenoid valves may, likewise, be connected to #5 & #6 where the PE control is used to control pneumatic or steam operated devices.

The control shown in Figs. 5 and 5A is designed to apply 110-120 volts across terminals #5 & #6 when a ray of light strikes the 930 RCA photo tube. There are many instances, however, where a device is to operate only if the continuous light beam is broken. In this instance values of bias resistors, and polarity of the photo tube are modified as shown in Fig. 5B. Form the PE control chassis of #16 gage aluminum to the dimensions shown in Fig. 5, making the socket and component mounting holes and bending chassis to the shape (as shown).

On the top deck of the chassis provide a 1-in. hole for the 930 octal tube socket; a 5/8-in. hole for the 50B5 pentode tube; a 3/8-in. hole for the rubber grommet, plus six 1/8-in. holes for mounting sockets and relay. Slot the center section as shown for

the 6-terminal connecting strip, and drill for four 6-32 mounting screws. The potentiometer mounts in a 3/8-in. hole. For the bottom deck, provide two 1/8-in. holes for mounting the 500 ohm voltage drop resistor.

This PE control uses only standard components available from all radio parts suppliers with the

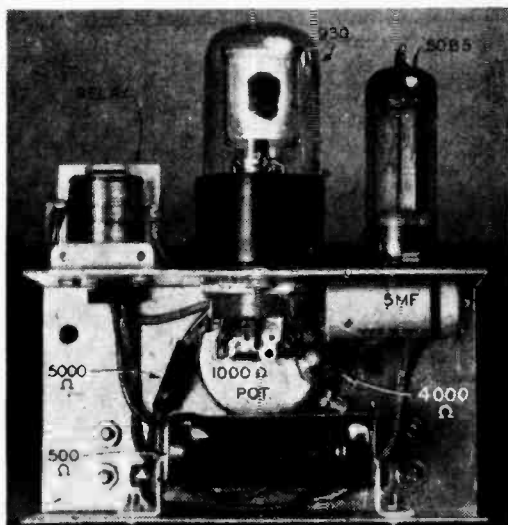

Fig. 4. PE control chassis, rear view. Chassis is in the form of a "C" for protection of components.

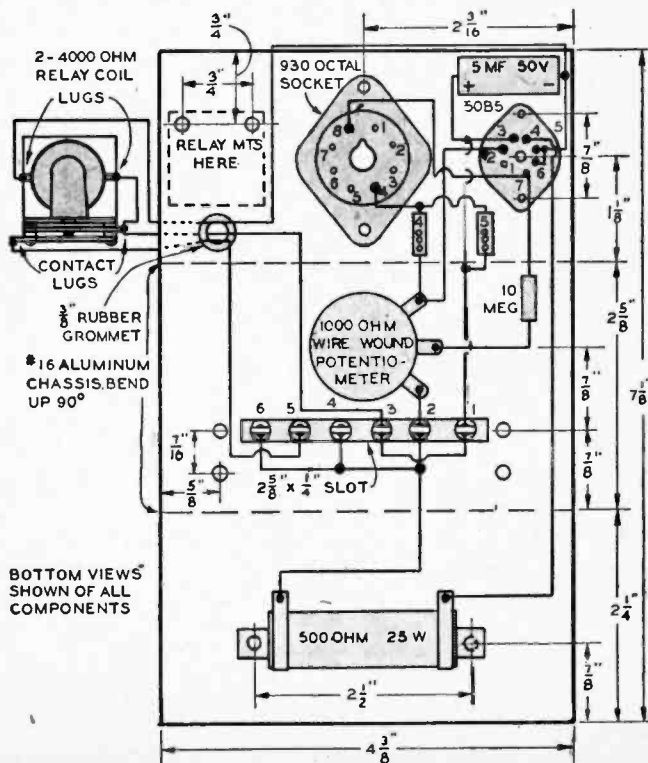
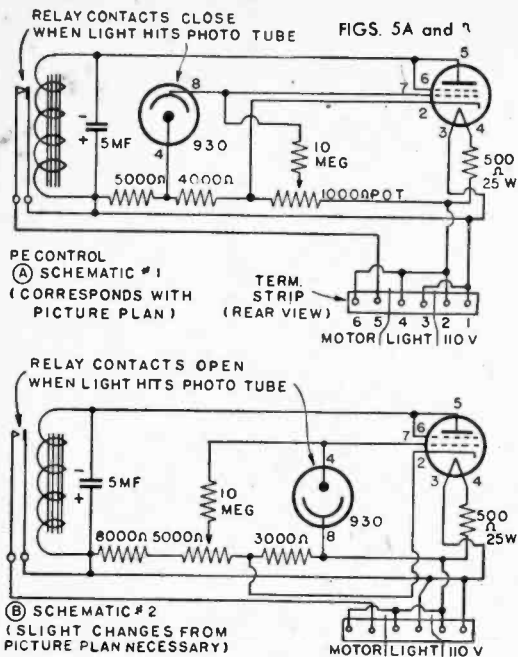

Fig. 5. Pictorial wiring plan and chassis layout for PE control.



exception of the metal housings, which are stocked in various sizes by all electrical supply houses. The boxes are normally used to house time switches, fuse blocks, switch gear, etc. Some boxes, such as the Paragon Type J used here, have two metal mounting ears to which the PE control chassis is secured. You can alter the chassis dimensions to suit the metal box used.

After carefully wiring the control with 50-50 grade

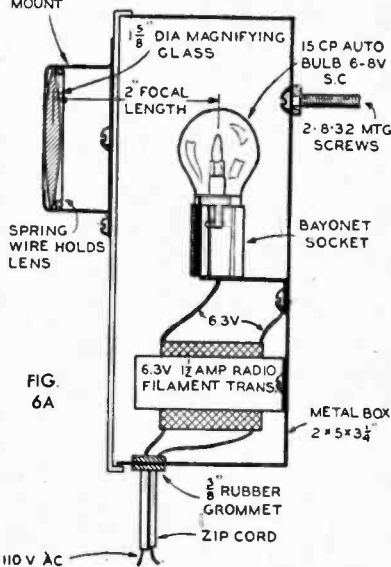
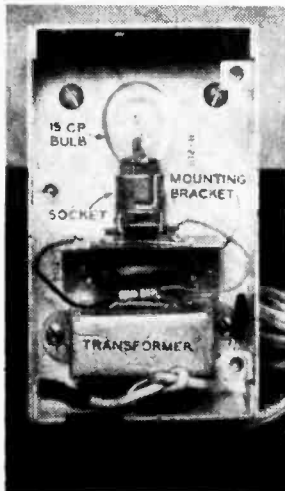

Fig. 6. Light source with cover removed. Transformer and lamp socket bracket are mounted to bottom of box.

rosin core solder (never use acid core), connect 110 volts to terminals #1 and #2. Drill a 1-in. hole in the box cover, along with a 3/8-in. hole to provide access to potentiometer adjusting screw, to permit control to be tested with a flashlight. Attach an ordinary Mazda lamp to screws #5 and #6 to test whether control works properly. Turn the potentiometer to far right, flash a beam aimed at the box opening and then slowly turn potentiometer counter-clockwise until the relay closes and turns on the Mazda lamp. Of course, the control has ample sensitivity to operate on moderate daylight illumination. Passing the hand across the 1-in. box opening should cause the Mazda lamp to go on and off.

The PE control lends itself to fire detection (Fig. 2F), and turning on or off lights with the coming of sunset or sunrise. Billboards along railroad right-of-ways, or highways, may be operated on a time-delay system by approach of train or auto headlights (Fig. 2C).

For industrial applications you need fast and positive control action. In such instances, a concentrated light source is desired so that even a very small object passing through the light beam will produce enough shadow to shade the photo tube and actuate the control. Use any small

metal container to house the light source; this model (Fig. 6) used a 2x5x3 1/4 in. aluminum box. To obtain the intense, concentrated light necessary, use a 15 candlepower auto spotlight bulb. The 6 to 8 volt lamp operates off a 6.3 volt radio filament transformer rated at 1 1/2 amps (Fig. 6A). Never try to use a bell transformer as they do not have the current capacity needed.

A single contact bayonet socket for the 15 candlepower bulb can be obtained at auto supply stores. Socket is mounted on a bracket over the transformer. In line with the center of bulb filament, a 1-in. hole is drilled in box cover for light to pass through. To concentrate the lamp filament use a simple optical projecting system (Fig. 6A). The lens is an ordinary magnifying type having a focal length, in this instance, of 2 in. and a diameter of 1 1/2 in. A local optician can grind the lens if you don't have a suitable reading glass handy.

To determine focal length, with the light source on, hold lens in front of the box opening and move it back and forth until the lamp filament is seen projected sharply on a wall at least 15 ft. away. The distance

MATERIALS LIST—PHOTO-ELECTRIC CONTROL

PE Control Parts

- 1—pc. #16 gage alum., 4³/₈ by 7¹/₈ in. for chassis
- 1—metal electrical box (Paragon J, etc.) approx. 8 x 4¹/₂ x 3 in.
- 1—Jones Barrier terminal strip #141, 6 screw type
- 1—sensitive DC plate relay, 2000 to 4000 ohms, s.p.s.t. or s.p.d.t. (All ed, Concord, etc.)
- 1—500 ohm, 25 watt wire wound resistor (Mallory, IRC, etc.)
- 1—octal plastic-molded or wafer socket (Amphenol, Cinch, etc.)
- 1—7-pin miniature molded or wafer socket (Amphenol, Cinch, etc.)
- 1—5mf., 50v. electrolytic capacitor (C-D, Aerovox, etc.)
- 1—10 megohm, 1/2 watt carbon resistor, IRC
- 1—type 930 RCA phototube
- 1—type 50B5 miniature pentode tube
- Misc. hookup wire, and hardware as needed; two 3/8" rubber grommets
- Parts for Fig. 5A Circuit**
- 1—4000 or 3900 ohm, 1 watt carbon resistor, IRC
- 1—5000 or 4700 ohm, 1 watt carbon resistor, IRC
- 1—1000 ohm wire wound potentiometer, IRC
- Alternates for Fig. 5B Circuit**
- 1—8000 or 8200 ohm, 1 watt carbon resistor, IRC
- 1—3000 or 2700 ohm, 1 watt carbon resistor, IRC
- 1—5000 ohm, wire wound potentiometer, IRC
- Light Source**
- 1—6.3v., 1/2 amp. radio filament transformer (Stancor, etc.)
- 1—metal box, about 5 x 2 x 3/4" (see text)
- 1—Amphenol "S" Above-Surface Socket Mount
- 1—single contact auto lamp socket
- 1—15 candlepower auto spotlight bulb
- 1—1 5/8-in. dia. reading glass, 2-in. focal length

measured between center of lens and the 15 candlepower lamp is the focal length (Fig. 6A). Should this distance be 4 instead of 2 in., use two lenses in the mount instead of one.

For lens mountings, attach Amphenol above-surface-mount (for Amphenol "S" type radio sockets) over the box cover opening with 3 screws. Fit the 1 5/8-in. dia. lens inside, and secure it with a band of string wire. Where precise focal adjustment is desired, you may slot the bracket to which the auto lamp socket is attached to permit bulb to be moved forward or back in the event that lens used has more or less than an exact 2 in. focal length.—T. A. BLANCHARD.

Clip Holder Keeps Service Manual Open

• Service manual pages or construction prints have a habit of shifting or closing after being opened at the desired page. One method of keep-

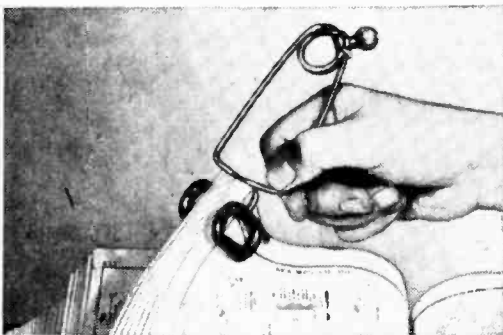

ing such data sheets open where wanted is to use a clip-on holder from a lamp. The clip jaws are rubber covered and, if kept clean, will not damage sheets of book or prints.—H. LEEPER.

**RADIO EXPERIMENTERS:
MIDGET
POWER SUPPLY KIT**

110 VOLT FILTERED DC at 40MA

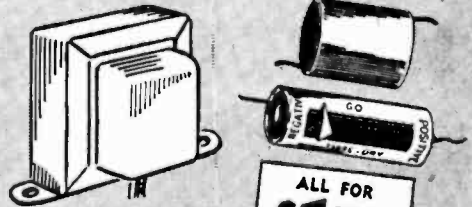

**AMAZING
LOW PRICE**

Here at a Big Saving you get Top Quality basic components for a Power Supply with many applications . . . for Mike or Phono Pre-Amp, Midget Radios or Audio Amplifiers, Photo Cell equip., Garage Door Openers, Code Practice Oscillators, TV Boosters, Test Equipment, etc.

Kit consists of a compact, fully enclosed Power Transformer, pri: 117 V, 60 cycle AC 110 V @ 40 MA. H.V. Sec., and 6.3 V @ 1 amp. for filament. A 35 MA-130 V. Selenium Rectifier and a 16 Mfd-150 V. DC wkg-225 V. peak electrolytic Filter Condenser . . . both very compact and easy to mount with the tinned wire leads. Wt. 1 1/2 lbs.

You Get All Above
No. 14B993. PER KIT **\$1.79**

COMPACT CABINET & CHASSIS



Cabinet is blank (no holes) except for ventilating slots. Modern design brown bakelite, size 8" W. X 4 1/2" H. X 4 1/2" D. Open side can be used as bottom or back. Adaptable for a wide variety of uses.

Chassis—Sturdy construction 7 1/4" W. X 3" D X 1 1/2" flange. Has hole for miniature socket, and drill holes for mtg. of other components. Can be easily altered for more socket holes and to specific needs. Exactly fits above cabinet and fastens to studs in cabinet by means of spring wires (included). Wt. 2 lbs.

No. 32A189. Cabinet & Chassis Both For . . . **\$1.29**

POWER SUPPLY KIT, CABINET & CHASSIS

No. 31B85. ALL FOR **\$2.98**

Order Direct from this Ad—Remit, with order including shipping charges—over-payment promptly, refunded.

FREE CATALOG—a complete listing of Everything in Radio Electronics, Television. Write for your copy if you do not already have one.

BURSTEIN-APPLEBEE CO.

1012-14 MCGEE ST. KANSAS CITY MO.



Fig. 1. The completed amplifier ready for connection to an FM tuner or phonograph.

MATERIALS LIST—AUDIO AMPLIFIER

- | No. | Item |
|-----|---|
| 1 | .0005 mfd. 400 v. paper condenser |
| 2 | .05 mfd. 400 v. paper condenser |
| 1 | .02 mfd. 400 v. paper condenser |
| 1 | 8 mfd. 450 v. tubular electrolytic condenser |
| 1 | 8/8 mfd. 450 v. electrolytic condenser (Mallory SR-638) |
| 2 | 50 mfd. 50 v. tubular electrolytic condenser |
| 1 | 220 ohm. 2 watt resistor |
| 1 | 1000 ohm resistor |
| 1 | 47,000 ohm resistor |
| 2 | 100,000 ohm resistors |
| 1 | 220,000 ohm resistor |
| 2 | 270,000 ohm resistors |
| 2 | 500,000 ohm potentiometers |
| 1 | 25 watt audio output transformer (Thordarson T22S74) |
| 1 | power transformer, 600 v. 120 ma., 5 v. 2 amp., 6.3v. 5 amp. (Thordarson T2-R05) |
| 1 | filter choke, 12 hv. 80 ma (Thordarson T20C53) or Amphenol 78RS8 |
| 4 | octal sockets |
| 2 | 2 connector terminal strips |
| 1 | chassis mounted microphone type connector (Amphenol 75-PC1M) |
| 1 | open circuit jack |
| 2 | bar knobs |
| 1 | replacement line cord and plug |
| 4 | mounting strips, 2 lug type |
| 1 | 2 foot length each: blue, red, yellow, green, black, push-back wire, No. 20 stranded wire |
| 1 | S.P.S.T. Toggle switch |
| 1 | 5Y3 tube |
| 1 | 6SL7 tube |
| 2 | 6V6 tube |
| 1 | 5 x 10 x 3" amplifier chassis |
- All resistors 1 watt unless noted otherwise.

10-Watt Multi-Purpose AUDIO AMPLIFIER

By ROBERT H. HAWKINS

THIS multi-purpose amplifier can be used with AM or FM tuners, or with a record player. The original has needed no service in the three years of its use. Three different types of connectors give a versatile input arrangement.

To begin construction, lay out on stiff paper a full sized template to dimensions shown on

Fig. 2. Fasten template to 5x3x10 in. steel chassis with Scotch tape, marking all hole centers with a center punch. Drill smaller holes with drills of proper size; cut those over 1/2 in. dia. with circle saws or punch with Greenlee sheet metal punches. The 1/4 in. holes shown near filter choke are for the filter choke leads. Put rubber grommets in holes to prevent wires

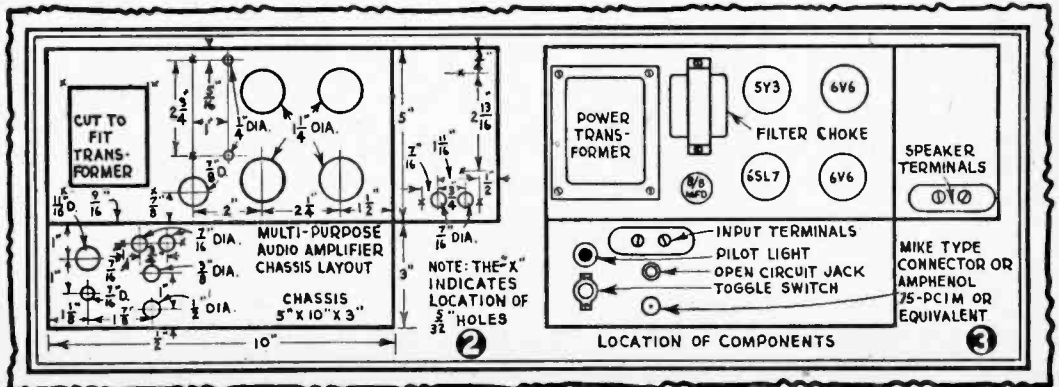

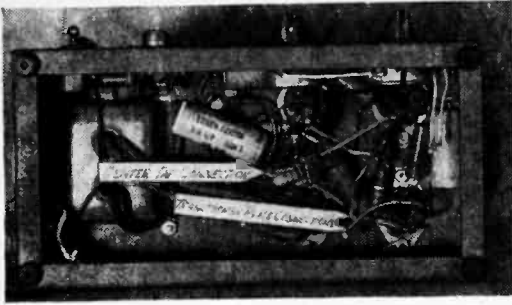

Fig. 4. Bottom view of chassis with output transformer removed to show wiring on sockets of 6V6 tubes. Single-pointed paper strip points to center-tap connection; double-pointed strip shows transformer plate connections. Note 2 white leads from output terminals at upper right.

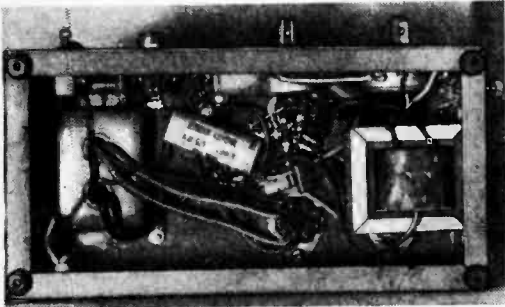

Fig. 5. Bottom view of chassis showing output transformer mounted in place at right hand side. White leads from the output terminals on end of chassis can be seen connecting to bottom of output transformer.

chafing on chassis. After all holes are drilled, remove any metal burrs from underside of chassis. Cut-out hole for mounting power transformer has been left with no dimensions, so use any transformer meeting the electrical specifications shown on the list of materials. An ampli-

fier foundation chassis was used in constructing the original (Fig. 1). While not necessary it does make a more portable and more attractive unit. Model used by the author was a Bud Radio, Inc. chassis #1750.

When chassis is completed, assemble major components in position (Fig. 3). Place ac leads for power transformer near back of chassis. Pins No. 5 of the 2 sockets for 6V6 tubes should be placed as near the 6SL7 socket as possible. This allows short leads and prevents the picking up of any ac hum. Placement of several solder lugs as well as the 4 mounting strips makes for ease and neatness in wiring the amplifier.

A color code system of wiring was used for ease in checking circuits. Use blue for plate leads, red for power supply B plus leads, yellow for screen grid leads, green for control grid leads, and black for filament and ground con-

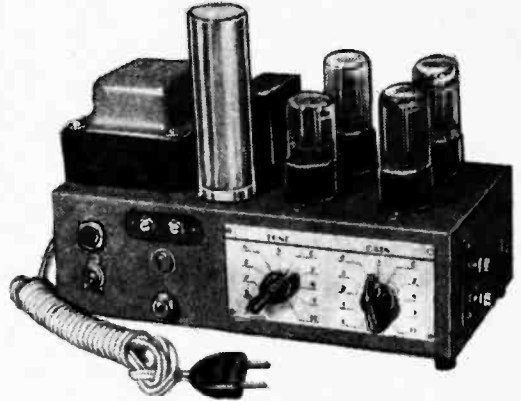

Fig. 8. Amplifier with cover removed to show parts placement. Filter choke is directly back of electrolytic condenser and 6SL7 tube near front of chassis is as close to input connectors as possible.

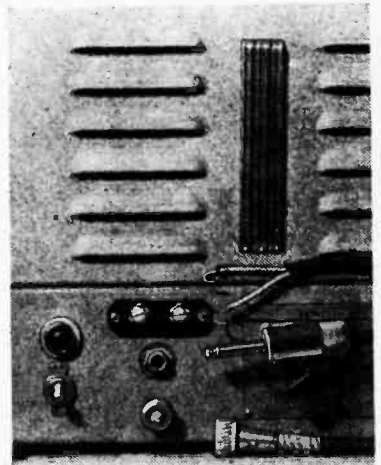
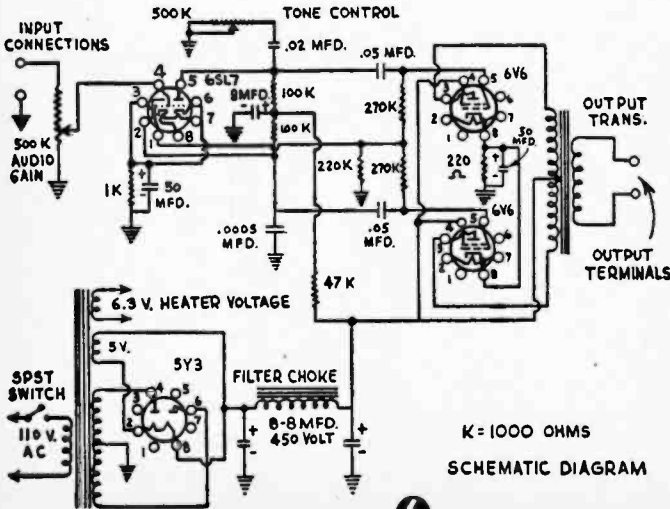

Fig. 7. Close up view of input connectors showing 3 types of connections possible with this amplifier.

nections. Do not mount volume and tone controls until most of the wiring is completed. First, wire all 6.3 volt heaters. Complete power supply wiring by using short, direct connections (Figs. 4 and 5). Next, place tubular capacitors flat against chassis which allows less chance for hum pick-up and gives more room for systematic placement of resistors. Connect three input connectors in parallel and add wire connecting them to volume control only after other wiring is completed. Metal chassis is used as a common ground connection, so be sure to remove paint under any solder lugs used for grounds. Make leads (white) from output terminal strip on end of chassis long enough to allow soldering to output transformer before it is fastened in chassis. Also leave plate leads from pins 3 of the 6V6 tubes slightly long. Any excess length can be removed after mounting output transformer into chassis. To add to finished appearance of unit use a Croname double style dial plate having tone and gain markings.

After completion of wiring, check it carefully. Connect a record player or FM tuner (using any of the 3 types of connectors shown) to input terminals and a good 10 or 12 in. permanent magnet loudspeaker to output terminals, and unit is ready to test. The 3 types of input terminals are connected in parallel, and only one terminal should be used at a time. Tone control in this amplifier is of the attenuator type which cuts off high frequency notes when adjusted to bass position, thus causing more bass notes to be heard in loudspeaker. This type of tone control will have some effect on the volume, so slight adjustments may be necessary on gain control when setting tone control to the most pleasing point.

Kitchenware for UHF Experimentation

• Plastic food containers make good looking loss chassis and cabinets for various ultra-high-frequency assemblies. Many of these containers are made of Styron, a member of the polystyrene family and a very good insulator. Containers are cheaper than sheet polystyrene, and come already formed. Photo shows 2 styles which are especially handy. The round one is an experimental FM crystal set using a germanium diode, which slope-detects close-by FM stations.—A. T.

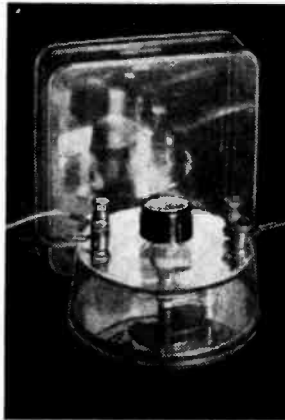

Handy Reel for Solder

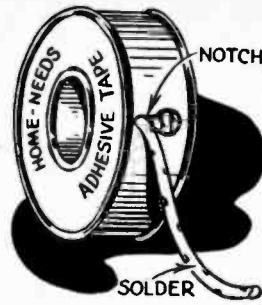

• Small household packages of solder that are not regularly supplied on a reel can be transferred onto a handy dispenser and holder by coiling them on a used adhesive tape reel as shown in the drawing. This does away with much of the direct contact with the solder and any escaped flux. Cut a hole at the side of the can for uncoiling the solder. A wedge-shaped notch at the side of the hole will lock the solder from receding back into the can.

Keeping Wire Solder Handy

• By supporting the spool of wire solder by wire hangers beneath the top of your metal working bench, and running the end through a hole

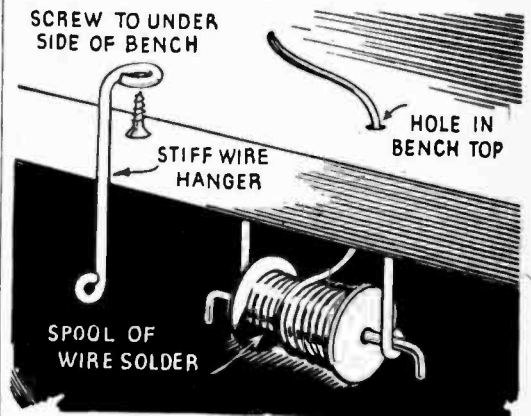

in the bench, you will have solder always within handy reach. A bend in the end of the wire will prevent its slipping through the bench.

Soldering Flux in a Spool

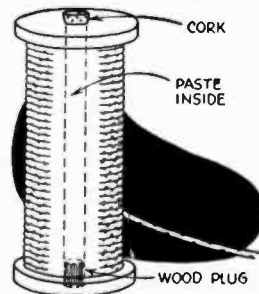

• Soldering flux, in paste form, can be kept inside of the hole in the spool on which the wire solder is wound. Tightly close one end of the spool with a wooden plug and insert a small cork in the other end. Time and space can be saved by this arrangement, and the flux and solder wire are always together. 105 North Street
Coral Grove, O.

JACK BRYANT

Portable SUPERHET

This 3-tube, superhet, battery receiver is ideal for your camping, biking or boating trips this summer

By MILO A. ADLER

COMPACT and entirely self contained, this 3-tube receiver will even fit in a picnic lunch basket. Its performance is equal to that obtained from the average 5-tube table top radio. Since it is battery operated no rectifier tube (found in most table top models) is required, and the use of headphones eliminates the need for a power amplifier tube. Only the tubes needed for maximum sensitivity and selectivity are used. By eliminating the power tube, B battery drain is reduced from 12 *ma.* to about 3 *ma.* (milliamperes) and A battery drain from 250 *ma.* to 150 *ma.* This reduced battery drain greatly increases battery life and keeps cost of operation very low.

The receiver is built into a wooden cigar box which may be obtained from your corner cigar store. The box used here was a "Corina Larks" box with metal hinges and a catch to keep the cover closed. First remove printing stamped on the box by sanding until letters can no longer be seen. Next with a clean damp cloth, moisten outside of box



Tuning in the finished receiver.

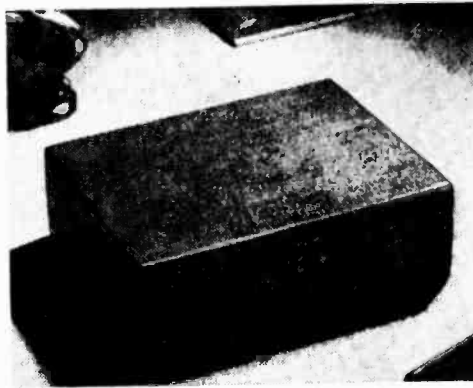

Cigar box finished and ready for the receiver to be mounted in it.

and allow it to dry thoroughly. Then sand box smooth and moisten again. After drying, give box a final, thorough sanding, and then apply two coats of shellac, rubbing with fine steel wool after applying each coat. A final coat of paste wax will put a glossy surface on the box. The chassis from a $\frac{1}{16}$ in. aluminum sheet, the surface of which is rubbed lightly with fine steel wool to produce a satin finish.

Tube sockets require a round $\frac{5}{8}$ in. mounting hole and the I.F. transformers require square $\frac{3}{8}$ in. holes which are notched in the corners to clear insulating studs protruding from transformers. The volume control requires a $\frac{3}{8}$ in. mounting hole. Make hole for variable condenser large enough to allow condenser to mount flush on back of panel. For simplicity only the centers for various mounting holes are shown on chassis layout. Arrows pointing from centers for tube sockets indicate direction blank section on tube socket should point. When mounting I.F. transformers, rotate them so that

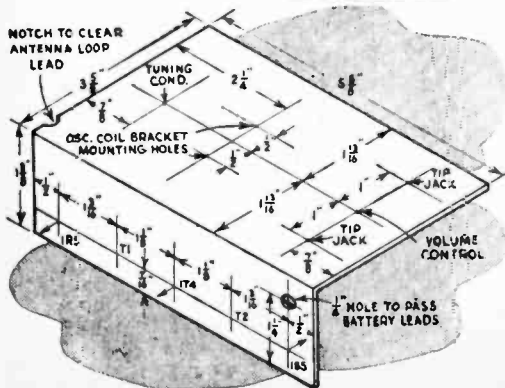

when terminals are bent they will almost reach correct terminals on tube sockets. Colors shown on schematic diagram are standard RMA color codes which identify 4 terminals of the I.F. transformers.

You can use any type standard loop antenna but loop should be small enough to fit into $5\frac{7}{8}$

$\times 6\frac{3}{4}$ in. cover of cigar box which has inside dimensions of $5\frac{7}{8} \times 6\frac{3}{4}$ in. You may obtain a new loop from a radio supply house or use the loop from a discarded radio receiver. One of the miniature loops now on the market may be used if desired. However, due to their extremely small size they do not have as much

signal pickup which will reduce the sensitivity of the completed receiver. The loop is mounted by cementing it to the inside of the box lid. Connections to loop may be made to tubular rivets mounted in the paper frame of the loop before cementing it in place.

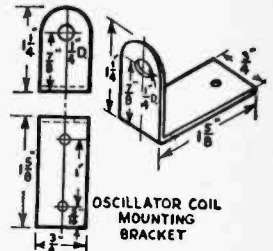
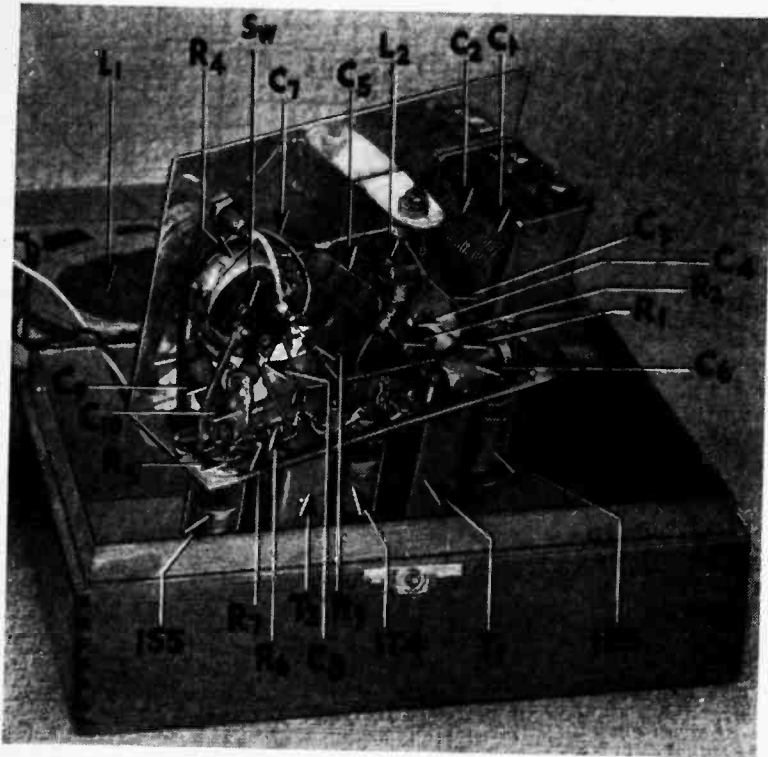

At left, underneath view of receiver, showing wiring of components. Identify parts by referring to schematic diagram. Note wooden block in right hand corner on which receiver chassis rests. A similar block is cemented in front right hand corner.

MATERIALS LIST—PORTABLE SUPERHET

- C_1-C_2 —2 gang cut plate variable condenser with trimmers (Allied Radio 61-008)
 C_3 —.00005 mfd. mica condenser
 C_4-C_5 —.02 mfd. 400 volt condenser
 C_6 —1 mfd. 200 volt miniature condenser
 C_7 —.0001 mfd. mica condenser
 C_8 —.005 mfd. 200 volt miniature condenser
 C_9 —.03 mfd. 150 volt miniature condenser
 C_{10} —.01 mfd. 200 volt miniature condenser
 R_1 —100,000 ohms $\frac{1}{2}$ watt resistor
 R_2 —10,000 ohms $\frac{1}{2}$ watt resistor
 R_3 —3.3 megohm $\frac{1}{2}$ watt resistor
 R_4 —1 megohm control (Mallory MR-53)
 R_5 —10 megohm $\frac{1}{2}$ watt resistor
 R_6 —4.7 megohm $\frac{1}{2}$ watt resistor
 R_7 —1 megohm $\frac{1}{2}$ watt resistor
 L_1 —Loop Antenna
 L_2 —Meissner 14-1040 Universal Oscillator Coil
 T_1-T_2 —Stanwyck Midget I.F. Transformers
 Sw.—DPST Switch mounted on R_4 (Mallory M27)
 Misc.—3 amphenol type 147-500 miniature 7 prong sockets
 2 phone tip jacks; hardware; wire; solder
 1 1R5 tube; 1 1T4 tube; 1 1S5 tube

Now for the receiver wiring. Oscillator coil is a universal type with an adjustable iron core which may be adjusted to match any type of cut plate tuning condenser. Terminal numbers on oscillator coil in schematic diagram may be determined by chart furnished with oscillator coil (see diagram). Condenser listed in parts list is recommended because of its small physical size.

Wire the filament circuit first. Next connect blue and green leads of I.F. transformers to correct terminals on tube sockets. By carefully bending terminals you can make them almost touch one another so that only a short connecting wire need be used. If these wires are longer than about $\frac{1}{4}$ in., either or both tube sockets and I.F. transformers have been mounted incorrectly.

All ground terminals are connected to soldering lugs on chassis; these, in turn, are wired together. Connecting grounds together in this manner keeps resistance in ground circuit at a minimum and assures maximum performance from the receiver. One phone tip jack is not insulated from chassis and the ground connections are made to this jack. Another solder lug is

mounted under one of the nuts holding oscillator coil bracket. A jumbo-type solder lug is slipped over mounting stud of oscillator coil before this coil is mounted in its bracket. One ground is made by soldering a wire on frame of tuning condenser. The round metal tube protruding from the bottom center of the tube sockets acts as a shield between the terminals and should also be grounded.

Make connections to B battery using snap-on connectors which may be obtained from any radio supply house. Solder the three A batteries together with a heavy copper wire which will hold them in place. Flexible leads from this heavy wire connect the batteries to the set.

The receiver switch and tuning knobs must be extremely thin to allow lid of box to close. The large tuning knob was made from a piece of 1/4 in. tempered Masonite. The excess shaft cut from

the control was mounted in an electric drill and the Masonite blank for the knob was fastened to it. Knob was then "turned down" using the point of a sharp knife, and then hollowed out in back to clear heads of the three binder-head, 3/32x1/4 in. machine screws mounting the tuning condenser. Knob for volume control is made from a 1 in. plastic knob which is also "turned down" to reduce the knob thickness.

After the set has been completely wired and loop and batteries connected, it is ready for adjustment. Turn the set on and, with core of oscillator screwed completely in, turn tuning condenser until you hear a station. Then adjust I.F. transformer trimmers for maximum volume. These factory set transformers require little adjustment. If a signal generator is available, align I. F. transformers at 455 kilocycles. Next rotate tuning condenser until it is approximately 10 to

15° from the fully closed position. Now adjust oscillator coil core until local station nearest to 550 kilocycles can be heard.

Next rotate tuning condenser until local station at extreme high end of the band can be heard. Rotate tuning condenser until station can just be heard and then adjust padder condensers on oscillator or cut-plate section until station is received at maximum volume. If there has been an increase in volume repeat the above step until station is received with maximum volume. If the above steps reduce the volume, rotate tuning

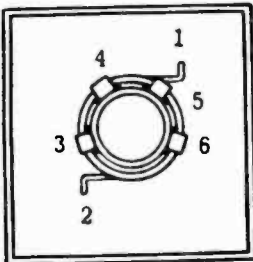
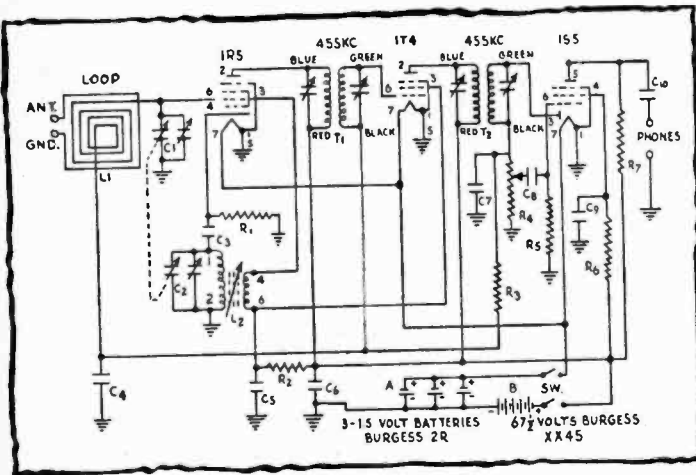

Universal oscillator installation data. Note space between lugs 3 and 6.

At right, completely wired chassis is shown in place in cigar box with batteries removed to show tube arrangement. Cigar box lid is propped open with a wire bent at each end and inserted into brad holes drilled in lid and box side.

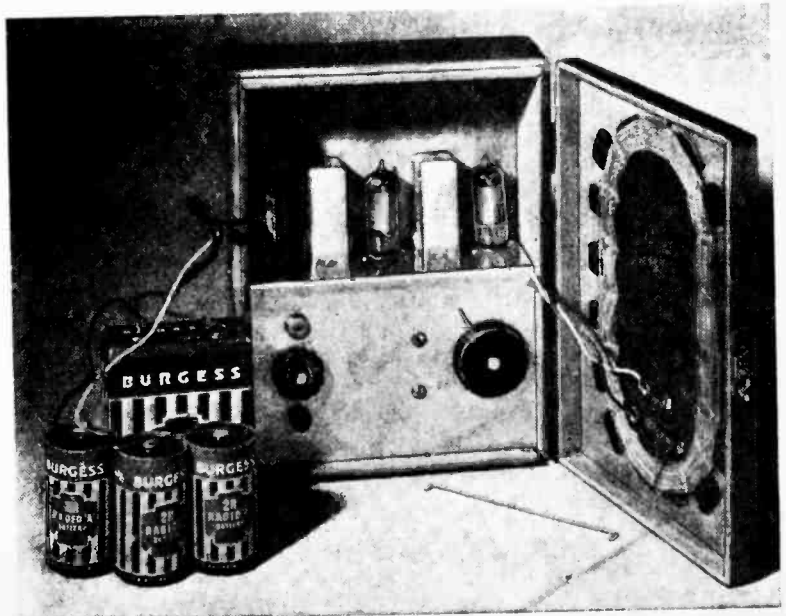

condenser in the opposite direction. Next adjust trimmers on large R.F. section of variable condenser for maximum volume. Then readjust core of oscillator coil as previously described and lock core in position. Then readjust oscillator and R. F. trimmers in the same manner as before.

Use headphones with a 2000 ohm or higher impedance. Loudest volume will be obtained from the phones with the highest impedance. If desired a paper dial may be mounted on the panel and the stations marked on the dial. However stations may be located without dial.

Loudspeaker for Your Superhet

Here's a method of converting your 3-tube superhet, battery operated receiver into a portable loudspeaker set for less than \$6. To make this conversion you add to the original battery receiver (See Fig. 5 and schematic) a power amplifier stage and speaker for loudspeaker perform-

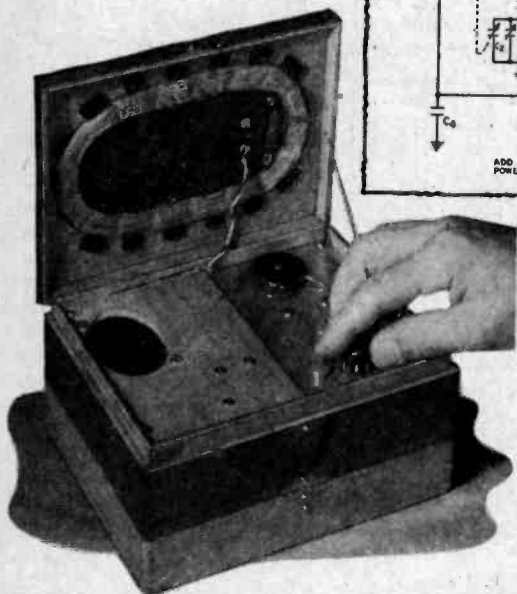
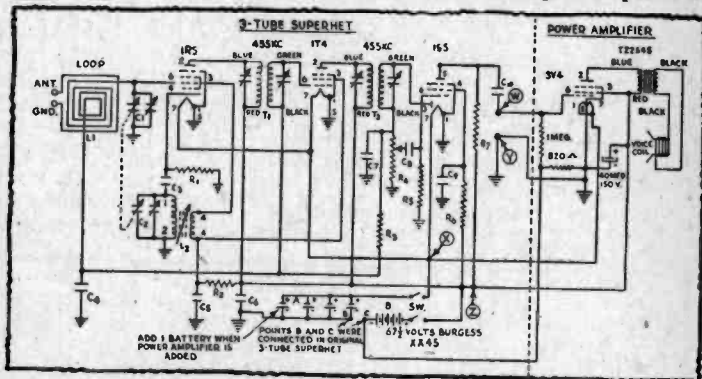

ance and increased sensitivity.

First secure another *Corina Larks* cigar box like the one which houses the original set. Remove the markings from the box as described in the preceding battery set article (*Portable Superhet*). Next pry off hinges and catch. Then cut bottom half of box down so that inside depth is 1 3/8 in. and sand edges smooth. Place box for the original 3-tube superhet on top of cut-down box, which is then marked and sanded so the two boxes match when fitted together. After fitting the two boxes, install hinges and catch so cut-down box is fastened to bottom of original box with both pairs of hinges and catches in line. Then finish bottom half of box to match top part. Start construction of power amplifier stage



Fig. 1. Battery compartment showing extra 67 1/2 volt "B" battery and parallel connection of four 1 1/2 volt "A" batteries. Note holes for passing leads and space for extra batteries.

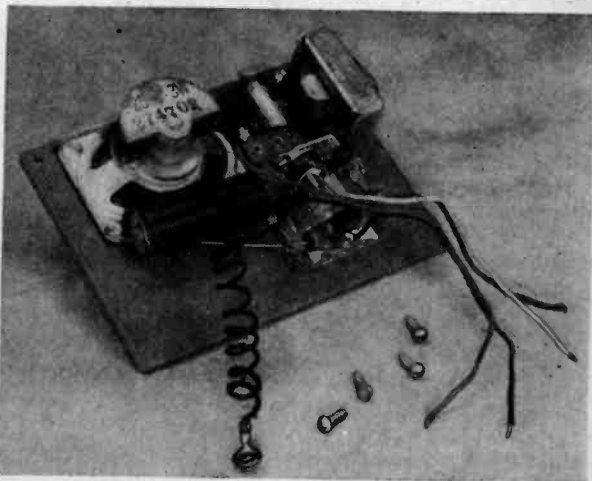
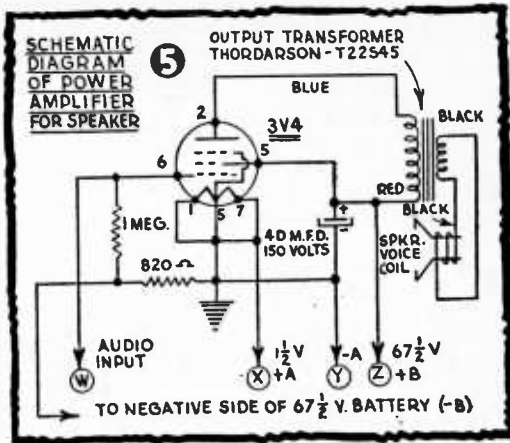
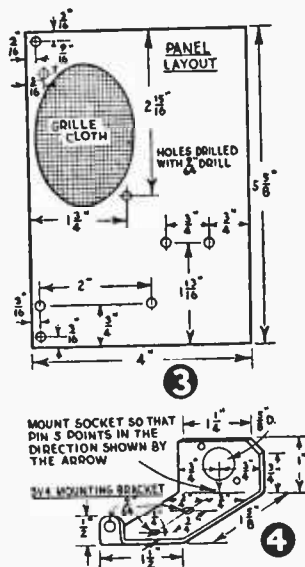

Fig. 2. Bottom view of power amplifier showing all new parts. The four wires are for connecting to points W, X, Y and Z. The coiled lead shown in the foreground is the negative lead for the 67 1/2 volt battery.

by making the front panel from the top of the dismantled box. Although dimensions in Fig. 4 are correct for items in the parts list, to insure proper clearance, check mounting position of each part as it is mounted. Install grille cloth or screen on front of speaker when it is mounted.

In wiring power amplifier make all leads as short and direct as possible and solder all connections carefully. Next remove all



play, check all connections and be sure there are no short circuits. One of the I.F. transformer cans may be shorting a terminal in the power amplifier.

Since adding power amplifier stage increases battery drain, use at least 4 A batteries. Although only one 67 1/2 volt battery is needed, for maximum battery life 2 of these batteries can be connected in parallel. There is also more than enough room in the battery compartment for more than 4 A batteries. Movement of batteries within battery compartment can be prevented by stuffing with newspaper or any similar packing.

Output transformer used was selected to provide proper match for the tube and 11.75 ohm voice coil of the 423S1 RCA replacement speaker. If any other type of speaker is used select an output transformer with a 10,000 ohm primary and secondary to match the speaker used.

PARTS LIST—SUPERHET LOUDSPEAKER CONVERSION

- 1—2 x 3 in. oval type speaker (RCA type 423S1)
- 1—820 ohm 1/2 watt resistor
- 1—1 megohm 1/2 watt resistor
- 1—40 mid. 150 v. elec. cond.
- 1—Thordarson T22S45 output trans.
- 1—3V4 Tube
- 1—7 prong miniature socket
- 2—Single insulated tie lugs
- 2—Solder lugs
- 8—8.32 x 1/8" machine screws
- 7—8.32 x 1/4" hex nuts
- 1—Corlin Larks cigar box
- 1—3 1/4 x 1 1/2 x 1/16" piece of aluminum

battery leads from the original 3-tube receiver. Then pass 4 wires from power amplifier for connecting to points W, X, Y, Z through hole in chassis formerly occupied by battery leads. Connect proper wire to point W, the phone tip jack, which is not grounded. Point X is A+ which is the side of the switch connected to pin 7 of the 1S5 tube socket. Point Y is the phone tip jack, which is grounded. Point Z is B+ which is the side of switch connecting to +B terminal on output I.F. transformer.

Reconnect battery leads for A+, A-, and B+ as they were connected in the original set. The B- battery lead comes from power amplifier. Then pass battery leads through the two 1/2 in. holes drilled in bottom of box. Secure receiver and power amplifier in the case with No. 6 screws in the small blocks glued in all 4 corners. Drill two 3/4 in. holes for passing these screws in receiver panel. (Screws were not needed in headphone model since batteries held receiver in place.)

Connect loop antenna leads and battery leads and turn on receiver, which should play immediately without any adjustments. If it doesn't

Versatile Alligator Clips

- You can increase the usefulness of your alligator clips by simply soldering 1 in. lengths of 12-gage copper wire to the back of one jaw of the

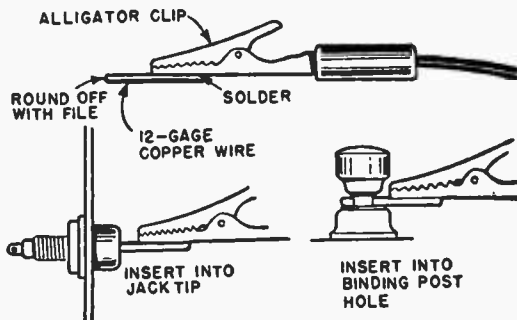

clips. Besides using the clips to snap on connections you can use them as test-prods, plug them into phone-tip jacks, or insert them into the holes in binding posts with non-removable screw-tops. —ARTHUR TRAUFFER.

Precision Electronic Timer

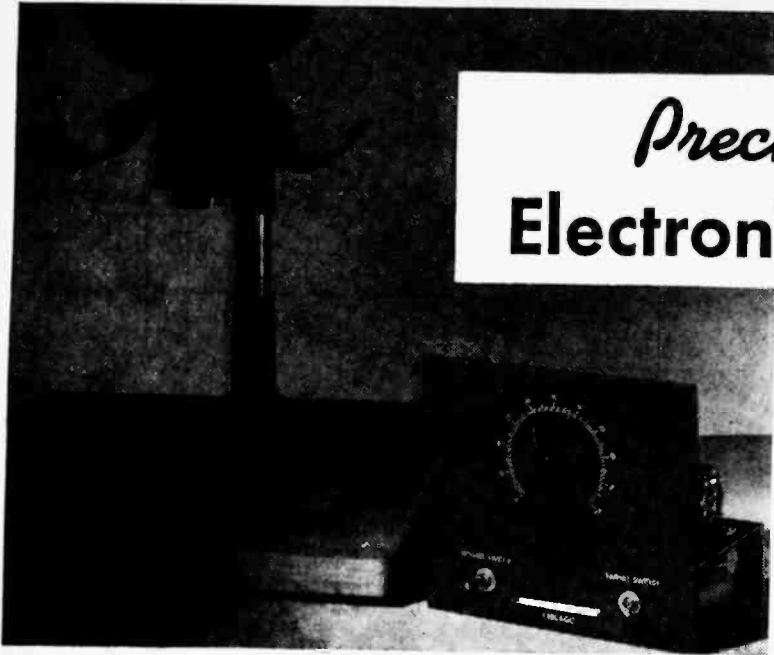

Try this versatile unit for photo printing, experimenting, or making flasher displays

By MILO A. ADLER

SIMPLICITY, dependability, and the ability to maintain accuracy after calibration were the three main factors considered when designing this electronic timer. The circuit is not complex and the number of components has been kept at a minimum. This timer will give accurate timing intervals in ranges from less than one second to over sixty seconds, regardless of line voltage variations, over the extremely wide range of 90 to 130 volts.

The plate relay used has double-pole double-throw contacts that are independent of the internal circuit of the timer. This versatile switching arrangement enables the builder of this unit to find countless applications for this timer. The experimenter may use the timer to accurately time the "on" or "off" period of an electrical device. The photographer may use it for accurately timing the exposure of photographic prints. Two of these units may be connected together for use in a flasher system where it is desired to regulate the duration of the "on" and "off" period of a window display or sign.

Parts needed may be purchased from radio suppliers by mail without difficulty. Special components are not used and all parts are standard units made by reputable manufacturers. The chassis used for the model shown in the illustration is 6 x 5 x 2 inches, and the panel is 6½

by 5½ inches. The chassis is laid out as shown in the pictorial diagram and illustration. The arrangement of the components is not critical and the only precaution necessary is to be sure the tube guide slots face in the direction shown in the pictorial diagram.

When wiring, either the pictorial or schematic diagram may be used. The pictorial is preferred for it shows the exact placement of wires and parts. Wire the filament circuit before wiring resistors, condensers, etc. Work slowly, checking each connection as it is made. An extra few minutes spent in careful wiring and thorough checking may save hours of trouble-shooting later. Be sure that the polarity of the electrolytic capacitor

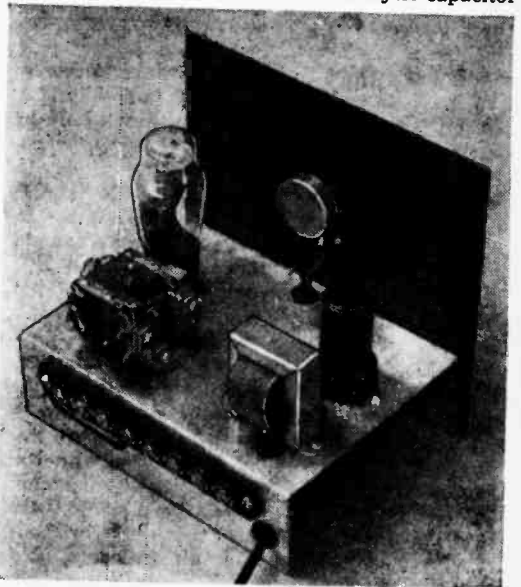

Rear view showing wire jumpers for automatic shutoff.

is observed when wiring it across the relay. The negative side must be connected to the plate of the 2050 tube. The right and left hand terminals of the timing control potentiometer may be determined by viewing the control from the back with the terminals pointing downward.

After the timer has been completely wired and the tubes inserted, the unit is ready for operation. The timer operates on 90 to 130 volts, 50 to 60 cycle ac only. The double-pole double-throw relay, as previously stated, permits the control of a large variety of circuits and of more than one unit at a time. To time the operation of any electrical device not drawing more than 800 watts from a 110 volt line, connect terminals 3 and 4 (or 6 and 7) in series with the device and the current source. Turn the power switch "On" and allow about one minute for the tubes to warm up. To start a timing cycle (the period of time for which the timer is activated), turn the timer switch "On." There will be a slight time lag of approximately one second; then the relay will close and the apparatus will operate until the timing cycle is completed. The timer switch must be left on for the duration of the cycle. If the switch is turned "Off" before the cycle is complete, the timing operation will stop. When the timing cycle is completed, the relay opens and current flowing to the device being operated is stopped. The switch may then be turned off, and the timer will be ready for a new cycle. To time an "Off" period for an electrical device that is normally on, connect terminals 4 and 5 (or 7 and 8) in series with the device and the current source. A remote switch, if desired, can be connected to terminals 1 and

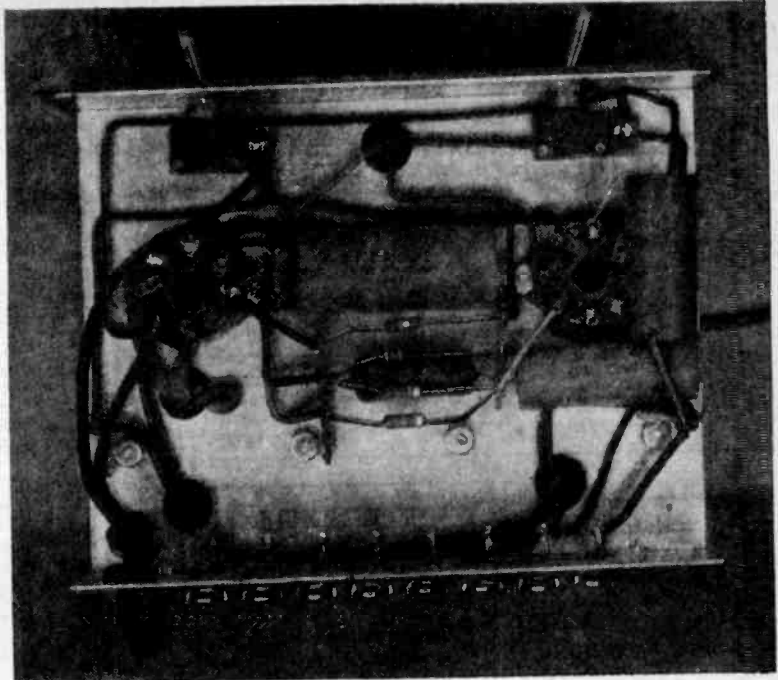

Underneath view showing components of the timer.

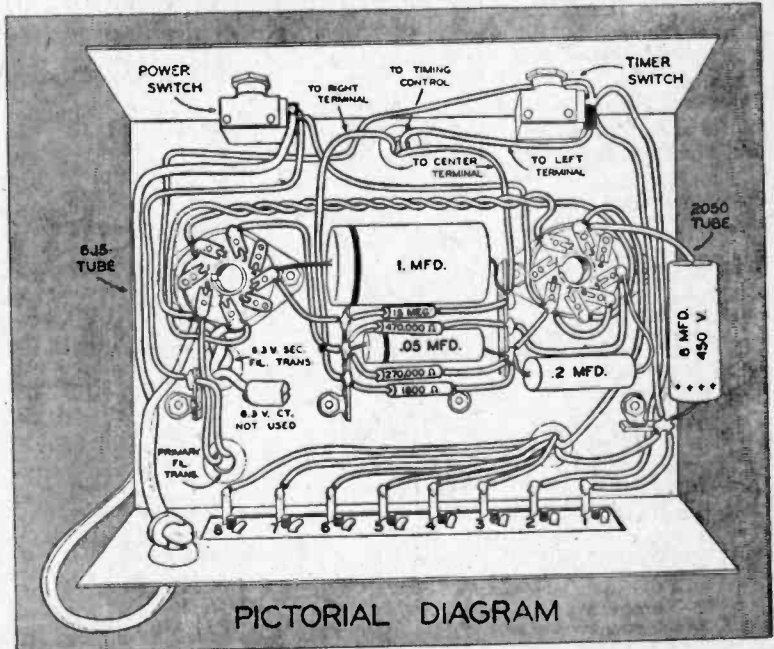

PICTORIAL DIAGRAM

2 on the terminal strip. If this remote switch is a momentary push-button type, connect terminals 1 to 3, and 2 to 4 with wire jumpers. Then it is only necessary to depress the push button until the relay closes. The switch may then be released and the timing cycle will complete itself.

The duration of the timing cycle is dependent

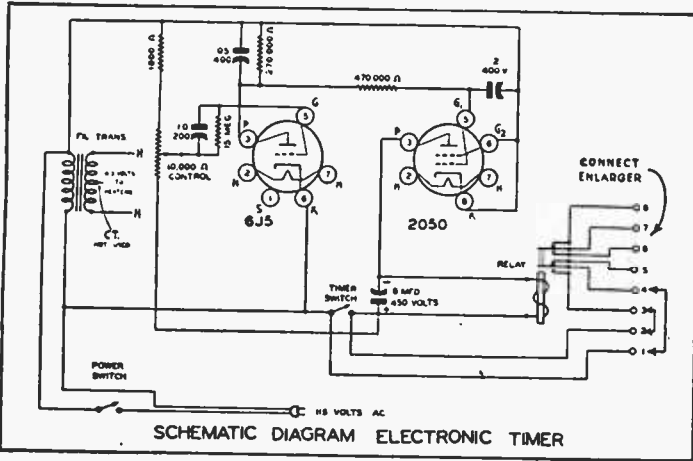

SCHMATIC DIAGRAM ELECTRONIC TIMER

upon the setting of the potentiometer and the value of the resistor across the 1.0 mfd. capacitor. The shortest timing cycle is obtained by setting the potentiometer at "0" (zero) and the longest cycle at "100." The 15-megohm resistor shown in the diagram gives a time range up to about 48.5 seconds. By using other values of resistors across the capacitor the max-

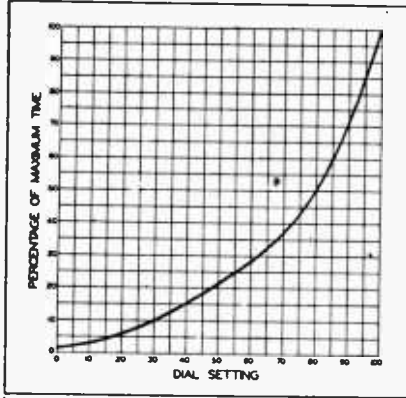

of resistor and condenser. Cycles of *in-between* duration lie between the two extreme pointer positions. These cycles do not vary in proportion to dial scale markings. The graph shown indicates with approximate accuracy the relation between the dial setting and the percentage of maximum time provided by any resistor. For example—when using the 15 megohm resistor—to obtain a time cycle of 4.85 seconds (or 10% of its maximum time limit of 48.5 seconds), observe the point on the graph where the curved line crosses the "10%" line and you will find that the dial setting should be 30. In cases where extreme accuracy is desired the builder of this unit may make his own calibration chart or graph. This graph should have the actual time in seconds, plotted along the left side in place of the "percentage of maximum time" as shown.

The 110-volt ac relay used in this timer has contacts rated to carry 8 amperes at 110 volts ac. If it is necessary to *time* the operation of an electrical unit drawing more than 8 am-

peres, a power type relay capable of handling higher currents may be controlled by this timer relay.

Balance of this discussion is a consideration of theory of operation and is not directly related to contact ratings of relay. With the *timer switch* open, as shown in the pictorial diagram, no plate

MATERIALS LIST—PRECISION ELECTRONIC TIMER

- 6 1/2" x 7 1/2" .064 Al. Alloy Sheet, Chassis
- 9" x 7" .064 Al. Alloy Sheet, Chassis
- 1—6J5 Tube
- 1—2050 Tube
- 15—Megohm 1/2 W. Carbon Resistor
- 1—470,000 ohm. 1/2 W. Carbon Resistor
- 1—270,000 ohm. 1/2 W. Carbon Resistor
- 1—1,800 ohm. 1/2 W. Carbon Resistor
- 1—10,000 ohm. wire wound potentiometer
- 1—1.0 mfd. 400 volt paper tubular condenser
- 1—.2 mfd. 400 volt paper tubular condenser
- 1—.05 mfd. 400 volt paper tubular condenser
- 1—8 mfd. 450 V. electrolytic condenser
- 1—6.3 V. filament transformer
- 1—DPDT 110 volt AC relay
- 1—2 1/4" bakelite pointer knob
- 2—SPST toggle switches
- 2—Octal tube sockets
- 1—8 terminal binding strips
- 2—3 terminal mounting strips
- 2—1 terminal mounting strips
- 1—Line cord and plug
- Hardware, wire and solder

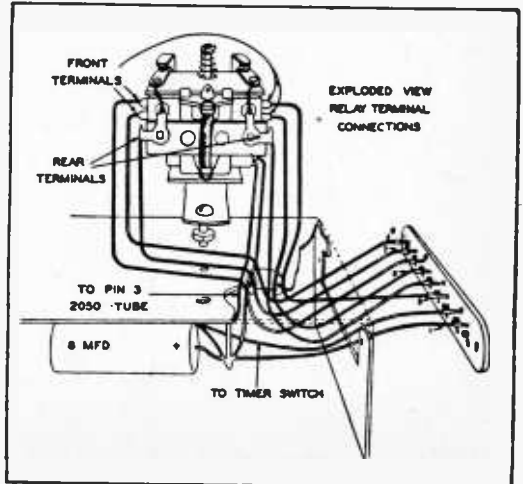

imum can be changed as follows: 1 megohm provides a maximum time of 3.5 seconds; 5 megohms, 14.8 seconds; 10 megohms, 23.5 seconds; 12 megohms, 30.5 seconds. Other ranges may also be obtained by changing both the value

voltage is applied to the 2050 thyratron tube. Therefore no plate current will flow and the timing relay will stay open. At the same time the grid and cathode of the 6J5 tube act as a diode, charging up the 1 mfd. condenser in the grid circuit of the 6J5.

270,000 ohm resistor. The resulting voltage drop across this resistor is applied as a negative bias on the grid of the 2050 thyratron tube.

The plate voltage applied to the 2050 is pulsating dc and the dc bias which has been applied to the grid of this tube stops the plate current flow. With the 2050 plate current flow stopped the timing relay is deactivated and it opens to complete the timing cycle. This process is repeated when the *timing switch* is opened and again closed for another timing cycle.

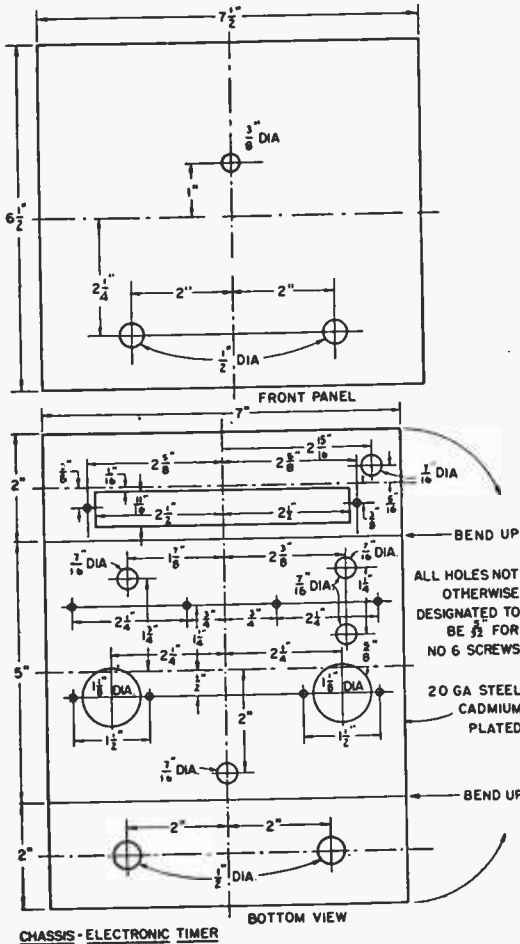

CHASSIS-ELECTRONIC TIMER

When the *timing switch* is closed the charge on the 1 mfd. condenser biases the 6J5 beyond the cutoff point, and no plate current flows through the tube and the 270,000 ohm plate load resistor. With no current flowing through this resistor no bias is applied to the 2050 tube and the tube conducts plate current which also flows through the timing relay and closes it.

The setting of the *timing control* determines the point at which the charge on the 1 mfd condenser no longer biases the 6J5 to cut-off. As the 1 mfd condenser discharges through the 15 megohm resistor in parallel with it the voltage across the condenser gradually decreases until this voltage is approximately equal to the voltage between the center arm and bottom end of the *timing control*. At this point the 6J5 tube conducts plate current which flows through the

Handy Counter from Radio Dial

- When keeping count of various products, jobs or parts you won't have to use paper and pencil, or rely too much on the memory, if you make this handy counter from a radio tuning dial salvaged from an old battery radio or from the junk

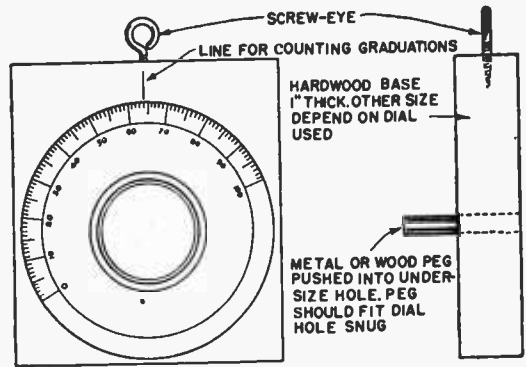

yard. Mount the dial on a 1 in. thick hardwood base with a hardwood peg friction tight in the dial hole. The length and diameter of the peg depends on the hole in the dial. A screw-eye allows the counter to be hung on the wall.—ARTHUR TRAUFFER.

Mounting Polystyrene UHF Coils

- Here are two methods for mounting home made polystyrene UHF coil forms. Drill an undersize hole in one end of a length of polystyrene

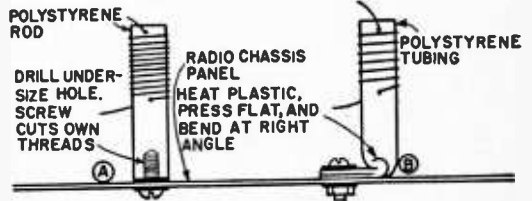

rod (A), and let the mounting screw cut its own threads. Use lock-washers when mounting. Heat one end of a length of polystyrene tubing, press the end flat, bend flat end at right-angles, and hold until cool (B). Drill a hole for the mounting screw through the flat portion.—ARTHUR TRAUFFER.

Electron III

Craft Print Project
No. 151



Side view of the completed Electron III.

How to build a 28-in., motor-powered, remote controlled cabin cruiser

By GILBERT M. TURK

Research Engineer

HERE is the very latest in scale model cabin cruisers—a model that will run rings around any single channel radio-controlled job on the lake. A unique remote control system permits you to run it without any expensive radio transmitters or receivers. What's more, no FCC license is required to operate the remote control unit. You just aim a beam of light, from shore, at the rotating photocell on the model and she responds to your command. You can make the model go right, left, forward, reverse, stop or start depending on the number of pulses or command signals transmitted. The transmitter is basically a source of light, having a concentrated beam that can readily be turned on and off. The receiver on the boat

consists of a simple amplifier and selector circuit. The command signal is received by the photocell, amplified and transferred to the selector circuit to obtain the desired operation. The rudder of the boat is held fixed; directional control being obtained by means of port and starboard propellers. The cost of building this model is about \$15.00 if you buy all parts (many parts may be salvaged from old gadgets, etc., however).

The boat is an exact scale model of the Owens 42 ft. cabin cruiser flagship, except for modifications in cabin to house photocell assembly, and use of 3 instead of 2 propellers. Hull con-



Above, view from port quarter shows hull and superstructure combined.



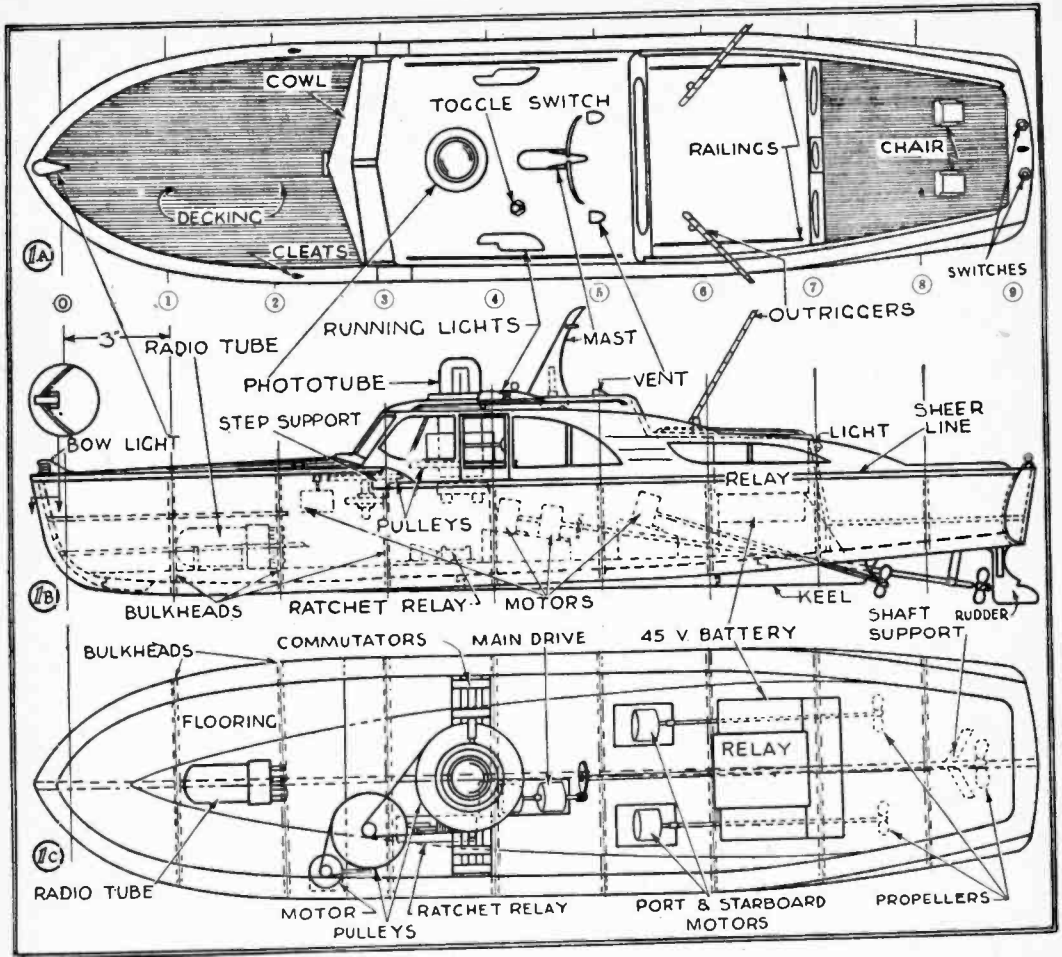

struction, as on the prototype, uses planked runners over a ribbed frame. All inverse curves are built up with $\frac{1}{16} \times \frac{1}{16}$ in. strips. A good grade model airplane glue is used for bonding all joints.

Start hull construction by tracing stem, keel sections and half views of frames on $\frac{1}{8}$ in. sheet balsa (Figs. 3 and 4). Tracing of each frame is inverted to obtain the full section. Cut along outer edges of outlines to allow for sanding the high spots. Undercut frame notches for $\frac{1}{8}$ in. square battens to insure a tight fit. The stem and 4 keel sections are laid along profile view of boat (Fig. 1B), and glued together. Glue the 3 sections of each frame together, number frames and sand outer edges with fine sandpaper.

Trace sheer lines and bulkhead stations on tracing paper. Use brads to fasten 2 building boards together (Fig. 2A). Cut tracing along third frame station and tack the 2 halves to the building boards to provide for the stepped deck. If the smaller building board is not the required height, use $\frac{1}{32}$ in. balsa shims to obtain the proper level. Now pin bulkheads to the tracing in their respective positions, with the deck side

facing the board. Make 4 vertical, equally-spaced shallow razor cuts on outer side of transom. Crack transom slightly along these lines to give the proper curvature, then fill cracks with glue. Cement keel and battens to notches in each frame. Add transom to frame, gluing keel and battens flush with outer edge of transom.

Before planking hull, locate all high spots on frames by laying a plank over a few frames at a time, noting whether or not it touches all points evenly. Sand all high spots lightly and glue thin shavings on all low spots. Next plank the hull from stern to bow, beginning at the keel. Put glue on section of each frame covered by a single plank, and hold plank in place with pins driven through plank into frame. Cut $\frac{1}{16}$ in. planking stock into $\frac{1}{2}$ in. strips, using these for lower section and upper stern section of hull. Use $\frac{1}{16} \times \frac{1}{16}$ in. planking on upper forward section of hull (Fig. 2A) to build up the inverse curves. The hull is constructed so as to have planking parallel to sheer line and keel. Planks along chine are lapped into place by running a scribe along the last laid plank, mak-

ing a pencil line along the following temporary plank. This plank is then cut along the line and sanded to give a snug fit. After planking has been completed, let glue dry 24 hours before removing pins. Trim and sand entire hull with a fine sandpaper.

At this point, make a rough working stand for the hull to facilitate further construction, using profiles of second and seventh bulkheads

BULKHEADS
 $\frac{1}{16}$ " SQ. Balsa

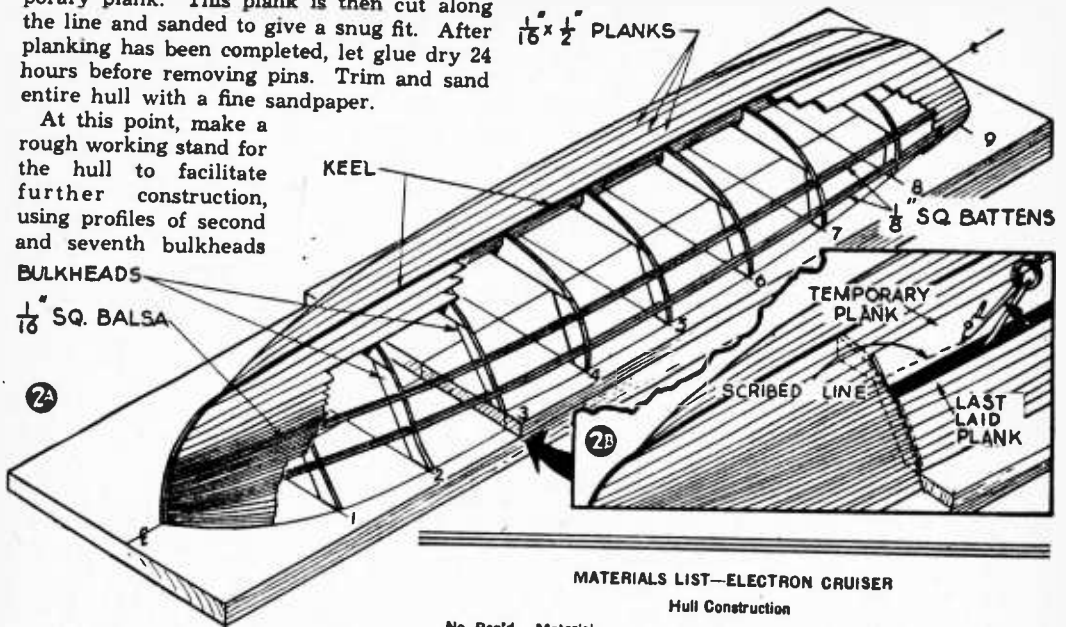

MATERIALS LIST—ELECTRON CRUISER

Hull Construction			
No. Req'd	Material	Size	Use
1	building board	8 x 44½ x ¾"	(for the base)
1	building board	8 x 33 x ¾"	(for the step)
50 strips	medium hard balsa	¼ x ¼ x 36"	(for deck and hull planking)
10 strips	medium hard balsa	¼ x 3 x 36"	(for hull planking)
6 strips	medium soft balsa	¼ x 3 x 36"	(for bulkheads and cabin assembly)
4 strips	medium hard balsa	¼ x ¼ x 36"	(for battens)
1 strip	medium soft balsa	¼ x 2 x 36"	(for photocell assembly)
1 strip	medium soft balsa	¼ x ¼ x 36"	(for photocell assembly)
1 strip	soft balsa	1¼ x 3 x 36"	(for stand)
	copper screening	8 square inches	(for lower cabin windows)
	caluloid	38 sq. in.	(for upper cabin windows and lights)
2	brass drill rods	10" long, ¼" dia.	(fishing outriggers)
	copper wire	24" long, ¼" dia.	(railings)
Propeller Shafts and Tubes			
1 pc.	tubing	¼" O. D.	(main sleeve)
2 pcs.	copper tubing;	11½" long	(auxiliary sleeves)
1 pc.	brass drill rod	¾", 8½" long	(main shaft)
2 pcs.	steel wire	¾", 11½" long	(port and starboard shafts)
1	propeller	1¼" dia. x 6" pitch	(right hand)
1	propeller	1¼" dia. x 6" pitch	(left hand)
1	propeller	1½" dia. x 6" pitch	(right hand—main propeller)
1	Mini-motor or Electrotor		(electric motors)
1		12-tooth gear	
1		36-tooth gear	

Note: Electrical and mechanical parts for the amplifier and selector circuit will be covered in Part II.

Tools Required

Safety razor blades; straight pins to hold pieces while drying; sandpaper; small hammer; pliers; soldering iron (pencil type is best because of its size and the limited working space); ½ pint of glue.

as templates. Trace outlines on ¼ x 3 x 36 in. balsa stock and sand smooth to fit hull curvature. Space 2 stand supports to 2 corresponding bulkheads in the hull, and join supports with sufficient ¼ x ¼ in. bracing to make a sturdy stand.

Apply 2 coats of clear dope or prepared wood filler to inside and outside of hull to seal all cracks and crevices along planking; it will dry quickly. Add 2 coats of light grey, flat oil paint, allowing 24 hours for first coat to dry. Then sand entire hull smooth before applying second coat. Use turpentine or Varsol to thin paint to a watery consistency for brushing or spraying. Before putting in flooring and sides, test hull for leaks under full load. Weigh 6 pounds of dry sand or other ballast and spread evenly along hull bottom. Float hull in your nearest pond (or bathtub) and check dry sand for leaks after 10 minutes in the water. Use Plastic Wood to fill leaky seams before applying another coat of flat paint. With hull watertight you are ready to install sides and flooring.

Flooring is constructed of ½ x 1 in. planks glued together on a building board and then fitted into hull. Draw a plan view of flooring by measuring floor width at each bulkhead and laying out these dimensions along their respective bulkhead stations. Flooring extends from stem to midpoint of sixth and seventh bulkheads.

Draw planking lines 7 in. apart along length of plan view and trace these onto ⅛ in. balsa. After cutting planks and gluing them together, fit flooring assembly into hull. Sand edges to insure a close fit on each bulkhead and glue complete assembly to bulkheads.

Sides are constructed of ¼ x 1 in. planks built up from flooring to deckline, and running from stem to transom. Since height of both sides decreases from stem to transom, you'll

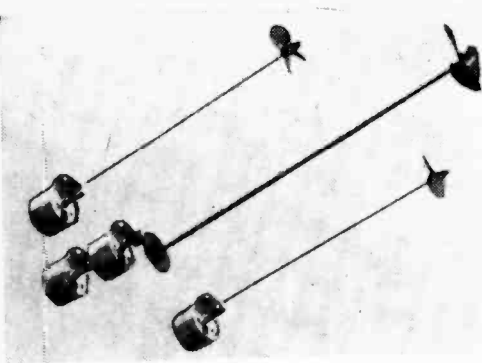

Power plant consists of 2 coupled motors geared to main prop shaft which propel boat forward or backward (center) and 2 auxiliary motors and props for turning controls (above and below).

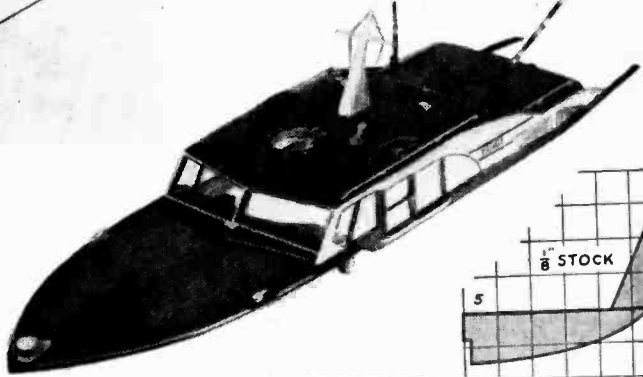
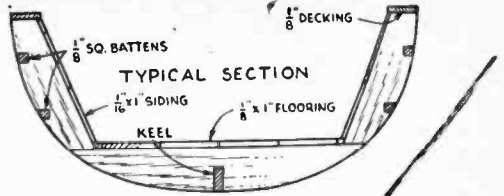

Right, superstructure is built as a complete assembly separate from hull.

need more planks along forward bulkheads. This means the planks will extend above deckline along the rear section of the hull. These may be trimmed level with deckline after the glue has dried hard. Trace 2 forward decking strips (Fig. 4) on $\frac{1}{16}$ in. sheet balsa. The center and rear decking strips are traced on $\frac{1}{8}$ in. sheet balsa. Cut these strips along outlines and glue them to tops of bulkheads to form a base for the superstructure.

The boat is propelled by 2 electric motors coupled together and geared to main propeller shaft using a 3-to-1 gear ratio (see photo). Make main propeller shaft sleeve of $\frac{1}{4}$ in. outside diameter tubing. Before installing sleeves, cut them to required lengths and roll them between 2 steel flat plates to insure perfectly straight sleeves. Remove all burrs from the ends after cutting. Since sleeves are somewhat larger than shafts, ends must be silver-soldered and drilled out to exact sizes of shafts. Bore a hole for main shaft sleeve through keel about on centerline of seventh bulkhead. Fill hole with wood filler and glue, then seal one end of sleeve with soap and insert sleeve. Adjust pitch of sleeve so 36 tooth gear at end of sleeve clears inside of hull. Sleeve should extend about $4\frac{1}{2}$ in. behind seventh bulkhead. Solder $1\frac{1}{2}$ in. diam. main propeller to shaft and insert shaft in sleeve. The 36-tooth gear is soldered or set-screwed to end of main shaft. Motors are coupled by a $\frac{1}{8}$ in. diam. rubber tube. Measure distance between motors accurately and bolt them to a $\frac{1}{8}$ x 1 x $2\frac{3}{8}$ in. aluminum platform. Drill holes in platform large enough to permit motors to be adjusted for perfect alignment. Use a set-screw or solder to fasten 12-tooth gear to extended shaft and mount entire platform on $\frac{1}{4}$ in. balsa supports. Supports form a box-like structure with a slanted top—the top being the aluminum

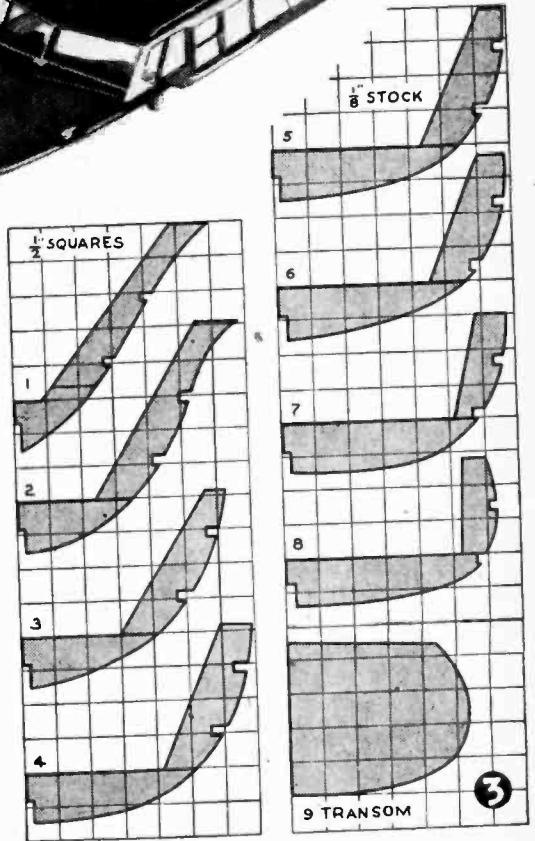

motor platform. Dimensions of supports are not given since they depend on sleeve pitch.

For top efficiency, align gears for a loose mesh, using balsa shims under main supports before gluing supports to hull. For turning, main power plant is automatically disconnected and 2 auxiliary propellers are used. Installation of port and starboard motors is the same as that for the main drive with a few exceptions. The $\frac{1}{8}$ in. copper tubing used for each shaft is located parallel to main shaft in top view and through bottom of seventh bulkhead, $1\frac{1}{2}$ in. on each side of keel. Auxiliary shafts should extend about $1\frac{1}{8}$ in. behind seventh bulkhead. The propeller

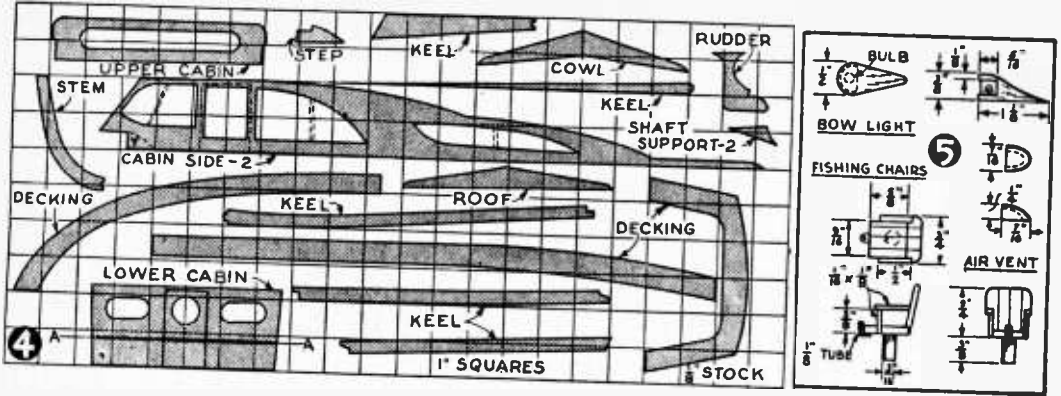

shafts are $\frac{1}{16}$ in. steel wire supported by silver solder bearings at each end of sleeve. Solder propellers to shafts and insert shafts into sleeves. The motors are directly coupled to propeller shafts by $\frac{1}{8}$ in. O. D. (outside diameter) rubber tubing. The supports are made similar to the main drive support, using a $1\frac{1}{2}$ x $1\frac{1}{4}$ in. aluminum platform. After accurately aligning motor shafts with propeller shafts, apply a heavy coating of glue to both shafts and slip rubber couplings over motor shafts. Insert propeller shafts through sleeves into couplings, allowing $\frac{1}{16}$ in. spacing between motor shaft and propeller shaft to take up any misalignment. Let glue dry for about 2 hours, put a few drops of light oil in each sleeve and connect 2 flashlight batteries in series to each motor. The propellers should spin freely about 1000 rpm; if not, recheck alignment of shafts. Since these motors are directly coupled to drive shafts, friction reduces speed much more than on the main drive shaft where torque is multiplied threefold.

Trace auxiliary shaft supports (Fig. 4) on $\frac{1}{8}$ in. balsa. Cut along outer edges and sand them down to conform to shape of hull directly above auxiliary shafts. Scrape a narrow section of paint from underside of hull above each shaft and glue supports to hull and shaft sleeves, being sure not to bend the sleeves. Main drive shaft sleeve is supported by a simple "V" type support of $\frac{1}{16}$ x $\frac{1}{4}$ in. balsa strips (Figs. 1B and 1C). Next trace rudder on $\frac{1}{8}$ in. balsa, cut out and sand the trailing edges. Insert a small polished rivet head or staple into leading edge of rudder directly in line with main propeller hub; this acts as a thrust bearing for the main shaft and removes excess play between mating gears. Scrape a narrow section of paint from hull and glue rudder in place, using $\frac{1}{8}$ in. supports on each side.

The forward deck and cabin is constructed as a complete assembly, separate from the hull. Any electrical adjustments may be made prior to running the model by simply lifting the whole assembly from the hull. Trace cabin sides and deck outlines on $\frac{1}{8}$ in. sheet balsa. Cut out carefully and cement celluloid to inner side of forward cabin window frames. Use copper

screening on all rear cabin windows.

The complete assembly is constructed on the 2 building boards used for the hull. Lay forward planking over a $\frac{1}{16}$ in. balsa base made up of two 3 in. strips. Pin two $\frac{1}{16}$ x 3 x 9 in. strips to upper building board about $1\frac{1}{4}$ in. from edge of step. Using forward decking strips as a guide, cut 2 base strips to fit between decking strips. Use a $\frac{1}{8}$ in. shim under base strips to get required deck pitch. Now glue base strips together along centerline and glue decking strips to outer edges of base. Plank forward deck with $\frac{1}{16}$ x $\frac{1}{16}$ in. balsa strips. Glue planks to balsa base, starting at centerline and working towards sides. Before gluing each plank in, lap plank over decking and cut forward end of each plank with a sharp razor blade to match the contour of decking. Cut cowl from $\frac{1}{8}$ in. sheet balsa and cement in place over planking. Cabin sides are pinned to lower building board and supported by forward roof beam and rear upper cabin section. Run five or six $\frac{1}{16}$ x $\frac{1}{8}$ in. crossbeams from one cabin side to the other for extra support and plank cabin roofs with $\frac{1}{16}$ x $\frac{1}{8}$ in. balsa strips. Now slide forward deck and main

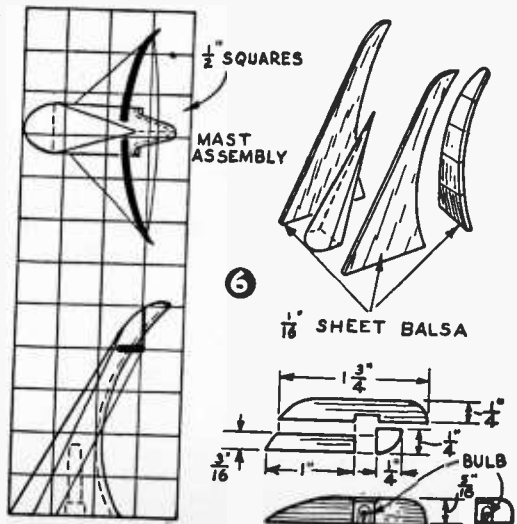

cabin assembly far enough from step on building boards so the 2 sections may be joined with the step supports. These step supports are cut from 1/8 in. sheet balsa and 4 are glued together for each side to equal width of decking strips, and glued to cabin sides (Y in Fig. 4). Slide forward deck section between cabin sides and step supports and firmly glue it in place.

Make the back of lower cabin in 2 sections (Fig. 4). Cut out portion above line A-A and glue it to cabin assembly. Cut 3 planking supports of 1/8 in. balsa sheet for rear section and glue them to sides of hull. Drill 2 holes through transom decking of superstructure and mount 2 toggle switches (Fig. 1A). Connect two 10-in. lengths of wire to each switch and run wires along inner edges of transom and underneath planking supports. These wires are connected later. After laying 1/16 in. square planking over supports, align glued lower section of rear cabin to planking, to match upper section of rear cabin.

Mounting Superstructure

With the basic superstructure completed, mark position of supports on each side of hull and cut a notch in hull planking to fit each support. Pin superstructure temporarily to hull and trim outer edges of the deck and cabin sides to get a perfect, square fit with the hull.

The 2 sides of each running light (Fig. 6) are carved from balsa blocks. After the pieces are assembled, glue a narrow strip of celluloid in a 90° arc to house the bulb. Tint penlight bulbs used for running lights red and green before installing them. Drill a hole for each bulb and push bulb through cabin roof until only glass envelope shows above roof. Sockets are eliminated by soldering wires directly to base of each bulb. Glue bulb to roof, then glue housing over bulb using filler or plastic wood around the edges for smooth contours. Carve bow light from solid balsa (Fig. 5). Cut a notch 1/4 in. wide and 1/16 in. deep and drill a hole through bottom section so complete assembly may be glued over the bulb. Drill a hole through forward decking and mount bulb and light assembly as shown. Mount rear cabin light in the same way.

Fishing Chairs and Mast

For the fishing chairs (Fig. 5), cut narrow slits in seat and back to simulate leather and cut a short length of 1/8 in. copper tubing for fishing pole supports. Whittle air vents from balsa blocks and hollow them out with a sharp razor blade (Fig. 5). Make outriggers of 1/16 in. diam. brass drill rods 10 in. long and paint black and white stripes on them, with a high gloss oil paint or lacquer. Don't mount outriggers until electrical controls are installed in the hull. Use 1/16 in. diam. copper wire for railings along cabin roofs. Roll wire between 2 steel flats to remove any bends and mount it using 1/16 x 1/16 x 1/16 in. balsa supports along the roof.



AUDEL'S T.V. RADIO SERVICE LIBRARY

2 VOLS. \$6 COMPLETE \$1 MO. PAY ONLY 10c.

HERE IS LATE INFORMATION IN A HANDY FORM FOR RADIO & TELEVISION REPAIRMEN, SERVICEMEN AND STUDENTS IT PAYS TO KNOW!

AUDELS T.V. RADIO SERVICE LIBRARY presents the important subjects of Modern Radio, Television, Industrial Electronics, F.M. Public Address Systems, Auto, Marine & Aircraft Radio, Phonograph Pick-Ups, etc. (Covers Basic Principles—Construction—Installation—Operation—Repairs—Trouble Shooting. Shows how to get Sharp, Clear T.V. Pictures, Install Aerials—How to Test, Explains Color Systems & Methods of Conversion, 1001 Facts—Over 1260 Pages—625 Illustrations of Parts & Diagrams—Valuable for Quick Ready Reference & Home Study. Tells How to Solve T.V. & Radio Troubles—Answers T.V. & Radio Questions.

Get this information for Yourself, 7 DAY TEST—ASK TO SEE IT!

MAIL ORDER
 AUDEL, Publishers, 49 W. 23rd St., New York 10, N. Y.
 MAIL AUDEL'S T.V. RADIO SERVICE LIBRARY 2 Vols. \$6 on 7 days free trial. If O.K. I will remit \$1 in 7 days and \$1 monthly until \$6 is paid. Otherwise I will return them.

Name _____
 Address _____
 Occupation _____
 Employed by _____ ANG

MONEY-SAVER KITS!

- No. 1—Basic one-tube training kit. Simple to construct. All parts: tube; headset; diagrams and instructions. Use 64 tube. Price less battery **\$3.95**
- 67 1/2 V. Battery.....
- Kit No. 2—2-tube amplifier kit—with 50L6, 35Z5 and 4" PM speaker—To convert Kit No. 1 to a 3-tube set for loud speaker operation..... **\$4.95**
- Kit No. 3—A low-priced, 6-TUBE KIT designed for high sensitivity, selectivity and good tone quality. Tubes: 25L6, 25Z6, 6XQ7, 6SA7, 6SK7, 6SK7, in an easily constructed circuit. Includes chassis, all parts, hardware, PM speaker, etc..... **\$6.95**
- Matched set of 6 tubes..... **\$3.25**

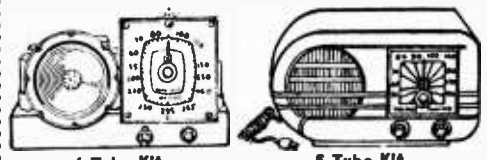

- 5 TUBE AC-DC SUPERHET KIT**
- Kit No. 4—5-tube superhet; AC-DC kit. Highly sensitive. Contains all components; complete with black Bakelite cabinet (less wire and solder)..... Price **\$7.95**
- Kit of tubes—12AT6, 12BE6, 12BA6, 35W4, 50C5..... **\$3.25**

ELECTRONIC CODE PRACTICE OSCILLATOR & Blinker Kit—AC-DC or Battery

- Kit No. 5—One of the most practical Code Practice Oscillators ever designed, yet simple to build and operate. Can be used with any number or type of earphones. Adjustable Pitch Control. No warm-up time needed. Simple and safe to operate. Can use AC-DC or 6U V. B-battery. Learn Blinker Code with flashing light. Can be used as Blinker signaling device. International Morse Code included. **\$2.95**
 - Kit \$1.95..... Assembled
- Satisfaction guaranteed on all merchandise. All prices subject to change without notice. Write for FREE Catalog.

RADIO DEALERS SUPPLY CO.
 154 Greenwich St. New York 6, N. Y.

The mast assembly (Fig. 6) is built up of 4 sides with a hollow center section to cover the potentiometer shaft. Cut 3 or 4 slits on inside of back piece and crack lightly along slits to obtain proper curvature. Cut front piece from solid balsa stock. Cut sides and crossbars from $\frac{1}{16}$ in. balsa. Glue sides and crossbars, and string mast with black thread as shown.

Now that the boat has been built, let's install the electronic controls

THE electrical control circuit for this cruiser was designed with 3 limiting factors in mind—space, weight and cost. Because the individual components are installed separately instead of mounting them on a single chassis, weight is distributed more evenly throughout hull. This also permits all component parts, excepting the photocell, to be placed within the hull and concealed by the superstructure, thus keeping the boat an authentic scale model of its prototype. Since the photocell protrudes only 1 in. above the cabin deck, it doesn't seriously detract from the model's realism.

The complete receiver consists of 2 basic amplifier and selector circuits (Fig. 8). The former amplifies a minute voltage change across the photocell (as light hits the cell) to a sufficiently high voltage to actuate a relay in the plate circuit. This relay in turn closes the selector circuit, energizing a ratchet relay which switches power on or off to the various motors. Since

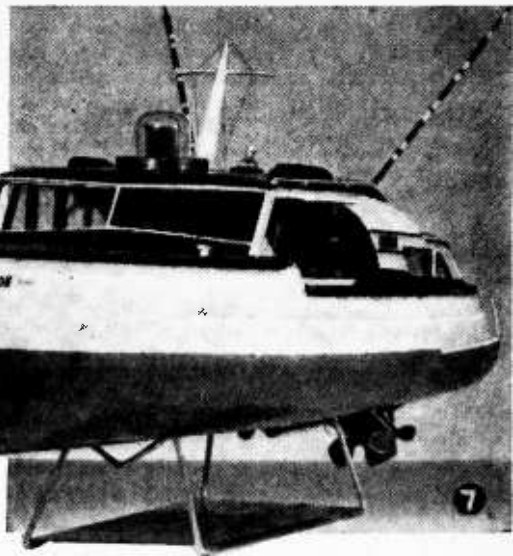

only 4 contacts are used on the 8-position ratchet relay, there will be a *neutral* or stop signal between each right, left, forward and reverse signal. Beginning at neutral, the first signal connects the auxiliary motors, propelling the boat to starboard. The next signal stops all motors; the third signal propels the boat forward, and so on. It may therefore be necessary to go through a complete cycle to follow a predetermined course. But this is no hardship, since the whole operation can be performed so rapidly that there is little noticeable effect. Just 5 or 6 quick signals and she's back on course. By means of a

rotating photocell, the light beam is always able to hit the cathode, regardless of the boat's position. The impulse signals may be made by the rotating photocell. Merely aim the light beam at the photocell. Each time the photocell cathode faces the

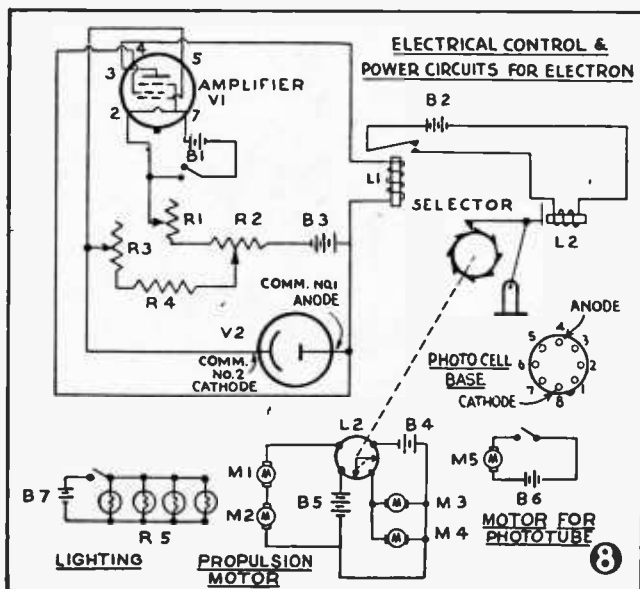

light beam, a signal will be transmitted to the relay. Keep light beam on the photocell until required number of revolutions has been made to obtain the desired operation. Having obtained desired action, turn light off before photocell makes another revolution.

You may buy the 8-position ratchet relay in this selector circuit (L2 in Fig. 8) from most hobby shops or #4014 from All-Nation Hobby Shop, 182 N. LaSalle St., Chicago 1, Ill. Remove one pair of contacts, leaving two contacts at a 90° angle. Or you may salvage it from an old model train engine. Ratchet switch is shown in an off position (Fig. 8); its 2 arms rotate clockwise together. Check relay secured to be sure it has switching arrangement shown in Fig. 8, and also check relay before installing it to insure positive action on 12 volts dc. (Fig. 10).

All control of boat is lost if relay sticks and fails to close electrical contacts. Apply a few drops of light machine oil to shaft and glue relay in place (see Figs. 1 and 1B).

Mount the 45 volt, hearing aid type battery (Eveready #455 or Burgess #XX30E) in plate circuit of amplifier on a balsa platform, perpendicular to keel and above the propeller shafts. If battery has no binding posts, insert a male plug in the socket before gluing battery onto platform. The single pole-single throw relay (L1 in Fig. 8) in plate circuit of amplifier may be purchased from most radio dealers or from The Lafayette Co., 100-A Sixth Ave., N. Y. C., for about \$1.50. This relay should have at least 2000 ohms resistance with positive action on 2 milliamperes current. Mount this relay on the 45

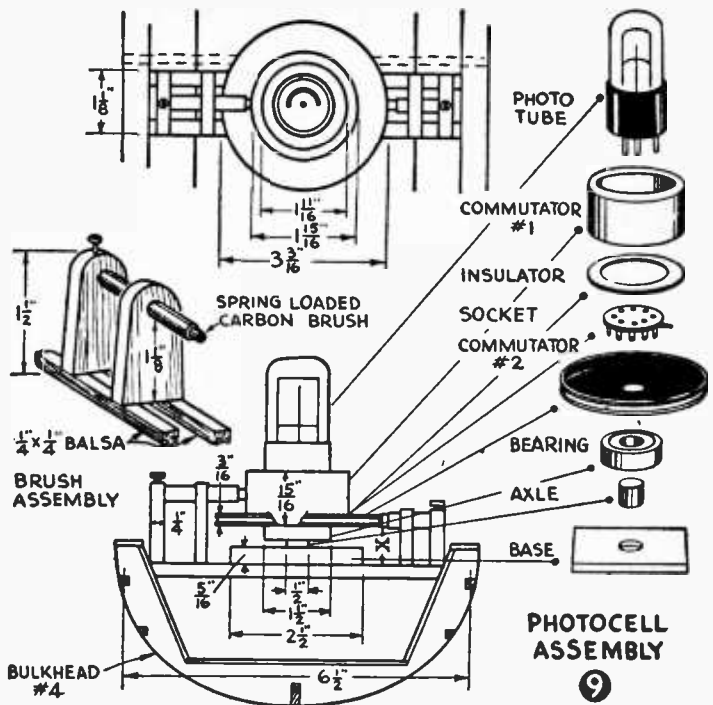

volt battery (Fig. 11) being sure the cabin roof clears the relay coils.

Mount IQ5 amplifier tube horizontally in the forward hull section (Fig. 1, Part 1). Measure tube diameter and cut 2 semi-circular templates from 1/8 in. sheet balsa for supports. Space these templates about 1 1/4 in. apart so as to fit under the tube's glass envelope and glue them to hull flooring (Fig. 1, Part 1). Push a wafer socket on the tube prongs before gluing tube to templates.

Fig. 9 shows entire photocell assembly. Rotating base for photocell is made by soldering a ball bearing (1/2 in. I.D., 1 1/4 in. O.D. by 3/8 in high) to a 3 1/8 in dia. x 1/8 in. pulley. Use acid core solder, then wash assembly in a neutralizing solution of baking soda. Pulley may be turned on a lathe or salvaged from the tuner assembly of an old radio; this pulley is commutator #2 in Fig. 8. It serves both as a speed reducer and as one of the photocell commutators. Solder all but one lug (the anode) of the phototube socket to the pulley, being careful to center socket on pulley. Use a metal cylinder (3/4 in. high, 1 5/16 in. O.D., 1/16 in. wall thickness) for commutator #1. An ornamental exhaust ring for car fenders may be bought from your nearest automobile supply store and used for this commutator. Saw mounting flange off the ring and mount it on the pulley, using a 1/16 in. balsa base to insulate it from the second commutator. Solder a short piece of wire from unsoldered socket lug to inside surface of commutator #1. Use an ohmmeter or a penlight bulb and dry cell to check for shorts between wired lug and commutator

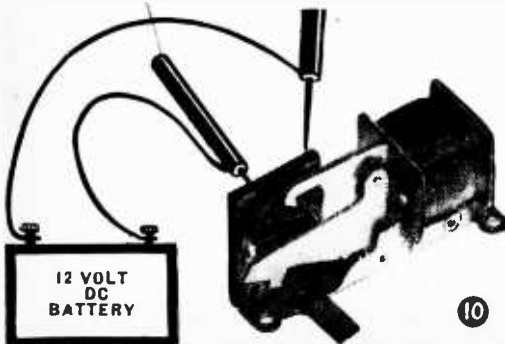

Check ratchet relay to insure positive action on 12 volts dc.

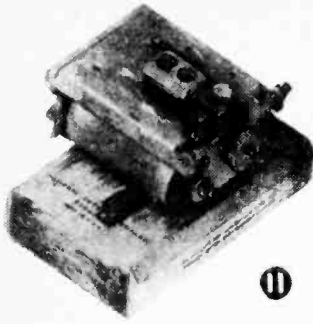

SPST relay mounted on top of 45 volt battery.

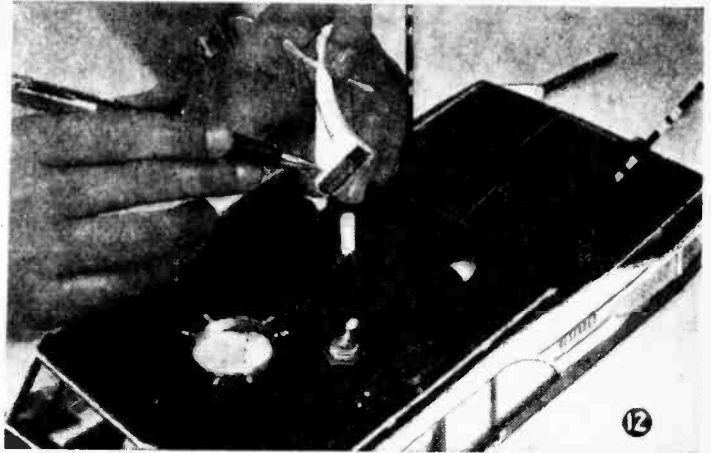

Mast has a hollow center section to cover the R2 potentiometer.

#2 (Fig. 12). Make the base of the rotating assembly of 2 pieces of $\frac{1}{4} \times \frac{1}{4}$ in. balsa cross-beams approximately $\frac{5}{8}$ in. apart. Glue a $\frac{1}{16}$ in. thick $x 1\frac{1}{8} \times 2\frac{1}{2}$ in. platform in the center of the cross-beam. Whittle a $\frac{1}{2}$ in. dowel to a slight taper to give a tight fit in the ball bearing. Cut dowel to $\frac{1}{2}$ in. length and glue it to center of platform. Now glue complete base in position slightly forward of #4 bulkhead. Glue cross beams high enough to sides of hull so that cathode of phototube clears top of cabin roof (Fig. 7). Check height of phototube assembly against that of cabin before gluing cross beams in place.

Make brushes for commutator of $\frac{1}{4}$ in. light coil springs or actual carbon brushes taken from any small electric motor, or the carbon element or center rod from the average flashlight battery. Mount these on balsa supports so they make firm contact with commutators, holding supports with pins until glue is thoroughly dry. Any foreign particles on commutators may cause a pulse in amplifier system and erratic operation of control circuit. Brush for commutator #2 rides on outer edges of pulley; the distance "X" in Fig. 9 depends on taper of axle.

Mount electric motor (Mini-Motor from Imperial Sales Co., 114-A E. 47th St., New York 17, N. Y.) which is used to rotate photocell assembly, vertically on balsa supports glued to hull siding. A $\frac{3}{8}$ in. dia., $\frac{1}{8}$ in. thick hardwood pulley is cut to shape and glued to upper end of motor shaft. Be sure top of this pulley lies below deck line. Mount a second $2\frac{1}{4}$ in. dia. pulley on a $\frac{1}{4}$ in. dia. shaft, $\frac{1}{8}$ in. from upper end. A short tuning dial shaft and bearing, purchased for a few cents at a radio supply store, will serve the purpose. Mount this shaft on a $1\frac{1}{4}$ in. balsa crosspiece so larger pulley is in line with the one on the motor shaft (Fig. 1, Part 1). Solder a metal cap to top of $\frac{1}{4}$ in. shaft to line up with commutator #2 on photocell assembly.

Use two, $\frac{1}{16}$ in. thick rubber bands for the pulleys, one from the motor to the $2\frac{1}{4}$ in. pulley; the other from $\frac{1}{4}$ in. pulley shaft to commutator pulley. Obviously, the center-to-center

distance of the shafts will determine rubber band sizes. Check tension of bands by turning motor shaft to see if photocell assembly will overcome friction of brushes. The pulley system should give the photocell a speed of about 40 rpm. An extra battery may be needed for the motor, depending on friction and tension of the system.

Locate position of photocell on cabin roof by accurate measurements or by smearing lipstick on top of phototube and putting superstructure on the hull so tube marks inside of cabin roof. Cut a hole through the roof with a sharp razor blade, and allow $\frac{1}{32}$ in. clearance around photocell. (This clearance may have to be increased if photocell is slightly off-center on commutator pulley.) A $\frac{1}{8}$ in. balsa or brass ring may be cemented on cabin roof around the hole to give the roof a "finished" appearance.

Drill holes through lower cabin roof for potentiometers R1 and R3 (R2 is mounted inside the mast—Fig. 13). Saw off potentiometer shafts so that shafts are only about $\frac{1}{2}$ in. above roof. Insert potentiometers from the bottom and secure them by a locknut above the roof. After final adjustments are made on these potentiometers, glue outriggers to deck and solder them to potentiometer shafts to lock the settings. The potentiometer under the mast is mounted in the same manner.

Don't glue the mast to cabin roof, since this potentiometer must be adjusted for the light conditions whenever the boat is run. Mount a toggle switch on the upper cabin roof as shown in Fig. 1, Part 1.

The wiring is all done with No. 18 gage wire. All leads from hull to superstructure are made at least 6 in. long so top may be removed and placed alongside hull. Glue 2 standard $1\frac{1}{2}$ volt flashlight cells to balsa supports on underside of upper cabin roof. Connect one toggle switch on the transom decking to filament of amplifier tube, the other to motor for photocell assembly. Make all battery connections by soldering wires direct-

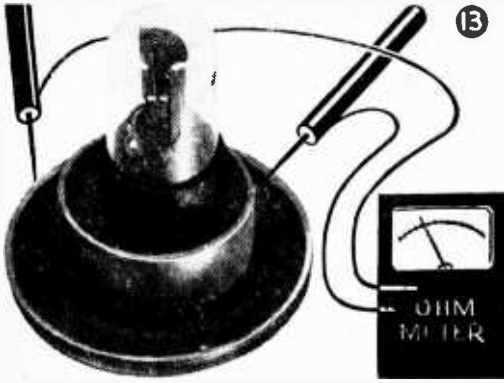

Use an ohmmeter to check for short between the 2 commutators.

ly to battery cases. Experience has shown that the life of the batteries is relatively long; however, battery holders may easily be made of hard balsa with copper terminal strips to facilitate battery replacements. You may glue running strips of $\frac{1}{16} \times \frac{1}{16}$ in. balsa along forward decking to match the appearance of this boat's prototype. The cleats may be purchased from any hobby store or whittled from balsa.

Apply one coat of clear outside varnish to forward deck and rear flooring, before using a light mahogany stain, to prevent stain from being soaked up too rapidly by dry planking. If you really want fine detail, cut narrow slits between each plank and insert thin pieces of white thread. After stain has thoroughly dried, add 2 coats of clear varnish, sanding with fine steel wool between coats. Give cabin sides and windshield frames 2 coats of flat white oil paint. Sand smooth and apply one coat of high gloss white oil paint. Give cabin roofs 2 coats of high gloss oil paint (dark blue or green). Trim the mast, hand rails, bow light, air vents and deck cleats in white. Paint bottom of hull (from keel to waterline) red, and hull section above waterline, white.

Since the range of control depends on the light source, an auto spotlight is recommended. Purchase an old automobile battery from any garage or connect spotlight directly to your car battery, providing you can drive your car close to the pond or lake. However, even a common flashlight will do the job over a limited range. You may want to improvise a sight on your light since you won't be able to see the light beam during the day, but after a few practice runs you will find that a sight isn't necessary. The area illuminated by the spotlight is large enough to make it fairly easy to hit the cathode simply by aiming "by eye."

To obtain accurate daytime control of the model, a shield is used to limit the amount of ambient light reaching the photocell (Fig. 14). By means of a fluted window on the shield, approximately 90% of light reaching photocell is generated by the light source. This shield ma-

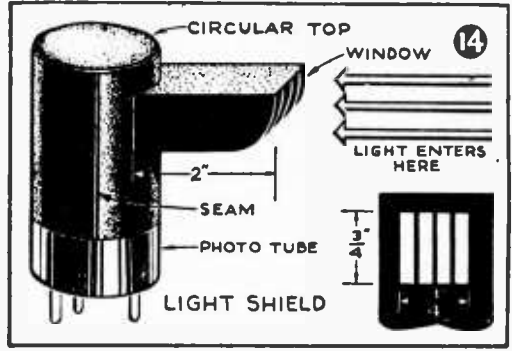

terially increases the daylight range of the unit and makes it possible to run the model any time during the day. Make the shield from thin cardboard or $\frac{1}{4}$ in. sheet balsa and place it over the photocell when the model is run. Measure distance glass envelope of phototube protrudes above deck and cut a rectangular sheet of balsa equal to this distance and long enough to completely encircle the envelope. Cut this strip in half and, to facilitate bending, hold 2 pieces around the tube with Scotch tape, and glue the seams together. When the sides are securely joined, slip this shell off the tube and cut out a top piece, by tracing the circular outline on another sheet of balsa. After gluing the top to the cylindrical shell, shield should slide snugly over envelope. With shield placed over phototube, cut out a small $\frac{3}{4} \times \frac{3}{4}$ in. window in line with cathode of the tube. Now cut 5 strips of $\frac{3}{4} \times 2$ in. balsa for the vanes. Top and bottom cover pieces are $\frac{3}{4} \times 2$ in. Cut ends of these pieces in an arc to conform to shape of tube. Round off lower leading edges of vanes to give a streamline appearance. Sand shield pieces smooth and apply 2 coats of black flat paint inside and out to kill all reflective surfaces.

Then stand vanes on edge, equally spaced, and glue top and bottom pieces to the vanes. Then glue this assembly over window on the cylindrical shield.

You are now ready to make the final adjustments and put your cruiser through its paces. Make the first few runs at night without the shield in order to get the "feel" of the controls and practice in aiming the light. The amplifier tube must be biased so that the relay is on the verge of closing under the ambient light conditions. This is done by adjusting the potentiometers on the deck. As seen in Fig. 8, R_2 acts as a vernier for R_1 , and R_1 is likewise used to get a finer setting of R_3 . Back off R_3 until relay fails to close with no light on the photocell. Repeat this same procedure for R_1 and make the final adjustment on R_2 . Then aim the spotlight at cathode of phototube, flashing light off and on while walking away from boat, until control mechanism fails to respond. Repeat this procedure for other settings of R_2 to determine maximum range of your control; this should be at

least 200 ft. Naturally the range may be increased considerably by using a higher powered light or an optical lens system on the spotlight and phototube. Having made the final adjustments, check control with phototube revolving. If phototube does not seem to respond to the light while it's turning, sand the contacts (brushes and commutators) to get a better connection and better operation.

Now you're all set to pilot your own cabin cruiser. Remember to take a kneeling position when using the spotlight so that light beam is parallel to the water and in line with the win-

dow on the shield when model is run during the day. It might be wise to tie a light piece of string to the bow of the boat for the first few runs until you can judge the control range accurately. From then on, cut the string and she's all yours, Skipper.

● Craft Print No. 151 in enlarged size for building the Electron remote-control model cruiser is available by order number for 50c (no C.O.D.'s). If you order more than 1 craft print (of this design or several designs), you may deduct 10c from the cost of each additional print. Address Craft Print Dept. L-52, SCIENCE AND MECHANICS, 450 E. Ohio St., Chicago 11, Ill.

A Safe Connection

● When making a wire connection for our radio, I cut two one-inch pieces from a half-inch rubber tube. I split these and put one around

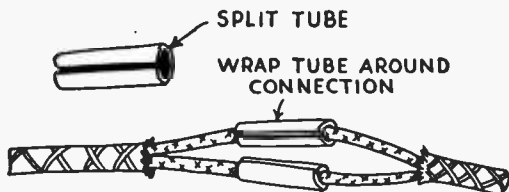

each wire at the connection point. Then I wrapped some tape over all, and it made a neat, safe job.—FRED CORNELIUS.

Polystyrene Tubing Insulates Chokes

● To protect the metal ends of an RF choke from accidental contacts in a crowded radio chassis saw a lengthwise slot on one side of a length of polystyrene tubing, and slip it over the RF choke. For straight-wound chokes, 1/2 in. OD tubing is about right, but for pie-wound chokes use larger tubing. Coil-dope or speaker-cement applied to wire leads where they enter tubing keeps tubing from slipping off choke. Or, heat the ends of the tubing and pinch them shut.—ARTHUR TRAUFFER.

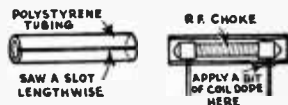

Repair Any of These

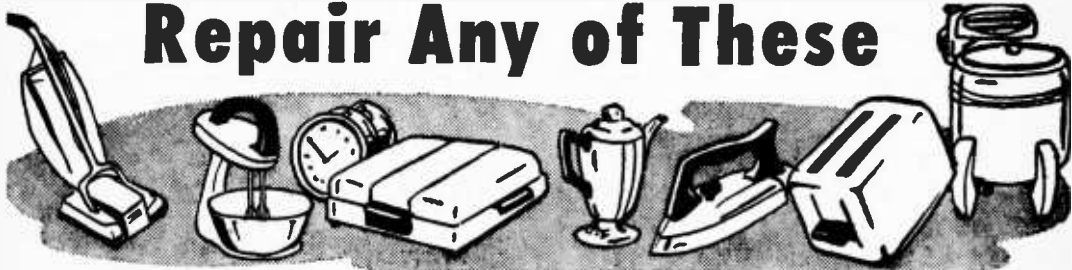

Handyman's Electrical Guide Makes You an Expert in an Evening

At last you can tackle any electrical job around the house with professional skill! The "Handyman's Electrical Guide," a new 192-page handbook for practical men, shows you exactly how to proceed on any electrical job. No questions are left unanswered. Written in simple, easy-to-understand language by men who are experts in their field. No previous electrical knowledge or experience needed! Now you can do your own electrical repair jobs and save hundreds of dollars. Nearly 600 illustrations—192 pages and 26 different "how-to-do-it" projects ranging from repairing toasters to rewinding motors.

TELLS HOW TO—Service Electric Mixers—Fans—Lamps—Washers—Irons—Vacuum Cleaners—Electric Grills—Toasters and Small Table Appliances—Car Clocks.—Service and Rebuild Motors—Build an Electroplating Outfit—Design Transformers—Repair Meters, and many others.

SCIENCE AND MECHANICS

450 East Ohio St., Dept. R-452, Chicago 11, Ill.

Send only **50c**



You will be amazed at the valuable information in this big handbook. On the very first job you can save 10, 20, or even 100 times the cost of the handbook. Order a copy today. Price 50c prepaid. (No C.O.D.'s, please.)

SCIENCE AND MECHANICS
Dept. R-452, 450 East Ohio St., Chicago 11, Ill.

NAME _____
STREET _____
CITY _____
ZONE STATE _____

"MAGIC ARM" Record Player

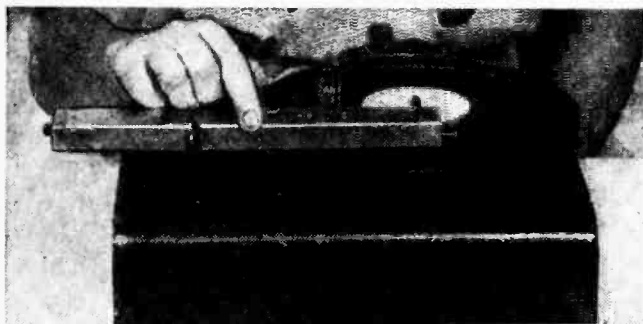

This self-operated, pocket-size pickup will "broadcast" music from your home, car or battery set

By THOMAS A. BLANCHARD

HERE'S an electronic record player you can carry in your inside coat pocket. Just set the "Magic Arm" alongside the turntable of a spring-wound or electric phonograph and turn on your regular radio. Music comes through the loudspeaker without connections. On picnics, use the "Magic Arm" pickup on your portable phono, turn on the car radio, and get high-quality phono-music audible for a couple hundred feet.

Old spring-wound phonographs, having a variable speed control, lend themselves to 33, 45 or regular 78 rpm discs. Because the "Magic Arm" operates on its own self-contained power supply, no damage or connections to either phono or the radio reproducing the music is involved. The secret is a flea-powered grid-modulated oscillator built into the pickup arm. Although the circuit employs only six components, results are really amazing. Cut pickup arm from a piece of light gage (#20) aluminum, copper, a tinplate salvaged from a 2-gal. cylinder oil can. If tinplate is used, reinforce metal channel on underside with soldered cross-braces to prevent twisting. Drill arm as shown in template plan. To make bends clamp metal in a vise between two strips of hardwood, or have some local tin-smith form the channel with his sheet-metal brake.

For swivel base use a large rubber suction cup sold by hardware and auto supply dealers or a rubber

cup sold for use under furniture casters, which provides a heavier and more desirable swivel base than the suction cup. This swivel is important and this bearing must turn freely.

Cut a strip of aluminum or steel and bend to form the swivel bracket. Attach to base with an 8-32 machine screw and nut and slip several washers on the screw to elevate pickup arm to suitable height to clear the turntable. Then draw nut almost tight on the bracket and smear a drop or two of Duco all purpose household cement on screw threads to keep swivel from working loose. A 6-32 x 3/8-in. screw in each side of pickup arm provides pivots so pickup rides in the forked bracket slots as indicated in photos. This arrangement is more convenient than hav-

ing swivel base permanently attached to pickup arm.

Mount the several components in positions shown in picture plan. The crystal cartridge may be any standard make. While unit shown is an American #CR-1, later tests proved that the Astatic #L-92-33 intended for LP records worked equally well with 78 rpm discs. However, the



The tube may be pulled out when pickup is idle. Note that arm merely rests in forked swivel base. For LP records, add a counter-weight to arm if needle pressure is excessive.

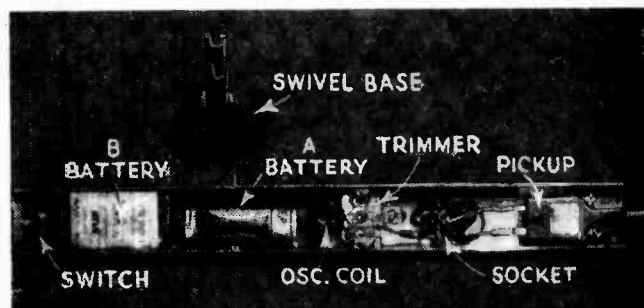

Bottom view of "Magic Arm." Parts positions correspond to accompanying pictorial wiring plan.

MATERIALS LIST—"MAGIC ARM"

- 1 pc. #20 aluminum, 10" x 2 1/4" (or tinplate—see text)
- 1 7-pin miniature wafer socket; 7/8 mounting centers
- 1 trimmer condenser (200 mmfd. to 500 mmfd. max.)
- 1 1/4 or 1/2 watt resistor; 1 megohm
- 1 1/4 or 1/2 watt resistor; 47,000 or 50,000 ohms
- 1 radio oscillator coil (Meissner or Bud "3-wire" bobbin type, etc.)
- 1 SPST slide or toggle switch
- 1 crystal phono cartridge; American #CR-1; Astatic #L92-33; Webster #C2; Shure #W42B; etc.
- 2 4-40 x 3/4" rh machine screws and nuts
- 2 1/2" spacers (or 4 extra 4-40 nuts) x 3/8"
- 2 6-32 rh machine screws and nuts
- 1 8-32 machine screw and nut
- 2 4-40 x 1/4" rh machine screws and nuts

MISCELLANEOUS

Hook-up wire and accessories

- 1 Olin #1915 22 1/2 v. B battery
- 1 Winchester or Bond size AA penlite cell
- 1 type 1T4 miniature pentode tube

Note: If you have a crystal pickup and do not wish to make up a special arm, you can obtain a kit from E. G. Little, Springdale, Conn. (\$3.00), which consists of all parts to build oscillator unit (including "L"-shaped aluminum chassis), but minus the tube, pickup and 2 batteries.

latter while it has the same mounting provisions as the American, is longer, and mounting holes for pickup must be moved 1/4 in. forward on pickup arm to accommodate it.

The crystal cartridge is supported on 1/2 in. spacers to elevate it sufficiently. Lacking suitable spacers, lock the two mounting screws to chassis with pair of nuts. Run another nut onto the screws, put crystal cartridge in place, and attach two final nuts to lock it securely. Pickup height is easily determined or varied by this method.

The "Magic Arm" is tuned by means of a trimmer condenser, which may have any value from 200 mmfd. maximum, to 500 mmfd. maximum. (The minimum values given in your radio parts catalog are not important). Mount trimmer on its accompanying bracket in position indicated.

If adjustment screw on trimmer does not have a mica, fiber, or ceramic insulating washer under it, make a washer to insulate screw head from metal leaf of trimmer. *Failure to observe this precaution will burn out the 1T4 tube.* The trimmer is usually furnished with a washer, but in some rare instances it may be missing.

The oscillator coil is a miniature unshielded bobbin type as used in superhet radios. All parts houses have them in 3- and 4-wire types. The 3-wire type is wired as shown in diagrams. The 4-wire type requires a jumper between end of primary winding and start of secondary winding; this point is then the tap. If you make the oscillator coil, first measure off 20 ft. of Litz coil wire and wind 10 ft. on a 3/8-in. wood or Bakelite rod. Leave a loop for the tap, then wind on the re-

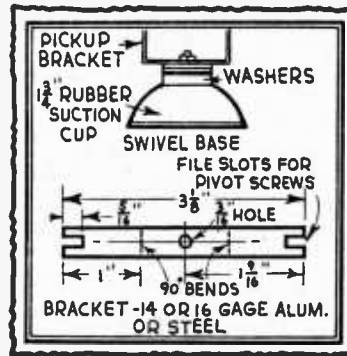
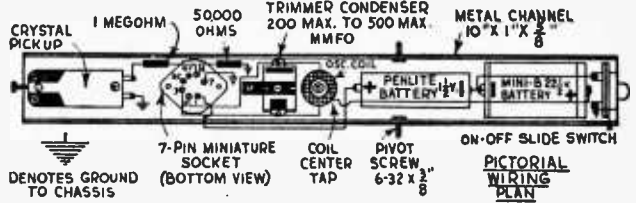
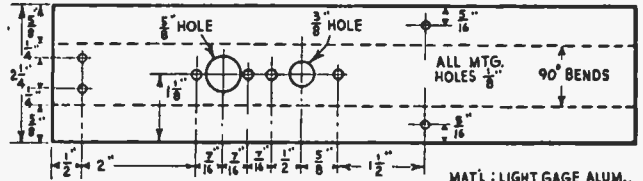

maining 10 ft. This coil may be scramble wound, but in order to fit the available space, layer-winding to form a neat bobbin is desirable. Ordinary enameled magnet wire about #32 B&S may be substituted. Homemade coils are not as satisfactory, however, as factory-made units. Two pies salvaged from an r.f. choke and placed close together may substitute for a factory coil.

The on-off switch is an inexpensive slide type soldered into the end of the pickup arm after cutting off the original metal mounting ears. Tin aluminum edges of arm with aluminum solder, and solder on slide switch with regular rosin core radio solder, 50/50 grade. For a simpler switch system mount an SPST toggle switch on top of the arm, close to the end so as not to interfere with the installation of the miniature 22 1/2 v. B battery.

The B battery (Olin #1915 as used in hearing aids) requires no gadgets to hold it in place since the metal channel was designed to provide a friction fit for it. The "A" battery is a Bond type AA or Winchester penlite cell. A short strip of light clock-spring or a corset stay forms a bow around it. The spring "stays put" through its natural expansion against inside of pickup chassis.

Wire components as in picture plan. Considerable wiring is eliminated by grounding parts, directly to pickup arm. Observe caution in connections to trimmer condenser lugs. Be certain neither of these lugs, nor wires attached to them, contact chassis, or a tube burnout will result.

To operate "Magic Arm," put a record on the turntable, turn on any home or car radio and set dial between 1600 to 1200 KC where no station is heard. Now turn on the pickup, and adjust trimmer screw until you hear a steady purr-

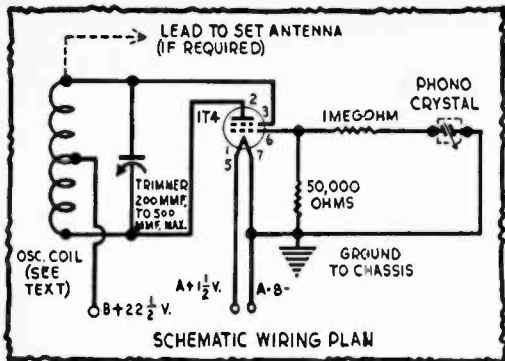

only of the inexpensive 1½ volt penlite cell. The miniature B battery will serve a long time. Solder leads from oscillator directly to batteries. Use light flexible wire for battery connections, so cells may be disconnected for easy replacement after removal from chassis.

A Tube Will Hold Screws

• If you have difficulties inserting screws in small space, you can solve this problem by putting a piece of rubber tubing on the end of the screwdriver. The tubing will hold the screw firmly and securely in place as you work the screw in.

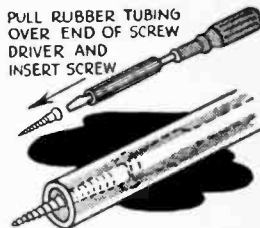

ing sound through radio loudspeaker. Once trimmer has been adjusted to a suitable frequency, it requires no further attention. Record volume and fine tuning, for best tone quality, is accomplished with radio dials.

When used with shielded car radios, and some sets lacking sensitivity, attach a length of insulated wire to one of the trimmer lugs. Merely twist the free end of the wire around the auto antenna or, if home set, to antenna terminal for ample pickup. It is not necessary to make a direct contact to antenna as ample capacitance will exist between set and pickup wire.

Your "Magic Arm" player will provide constant, trouble-free service, requiring replacement

Curling Iron Locater

• Finding a chain dropped down in a partition wall to pull electric wires to an outlet is simplified by using a curling iron for the purpose. Bend end of channel leg of iron slightly so chain won't slip out when tool is closed upon it.

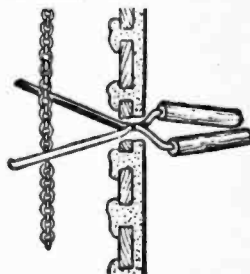

TRAIN *At Home* FOR OPPORTUNITIES IN

UHF-TV SERVICING

SET YOUR OWN PACE WITH THIS PRACTICAL PROGRAM!

Get in on the ground floor of this fast-growing field. Train now to cash in on the opportunities that are yours in UHF-TV SERVICING with proven, practical T.C.I. training. Here is non-mathematical training that's complete . . . down-to-cases . . . up-to-the-minute. Here is training you take in your spare time, without leaving your present job! Think of it—in your own home you learn TV set conversion, master antenna installation, the latest in UHF-TV, money-making short cuts and much more. You learn to trouble-shoot, test and repair TV sets the only practical way—by actually doing this work yourself!

HERE'S HOW YOU LEARN BY DOING!

You get the experience you need by working on a large screen, modern TV receiver that's given to you with the course and is yours to keep. As an optional feature you get two weeks of field experience on service calls and on the repair bench with one of Chicago's largest independent TV servicing organizations. You profit from the experience and know-how of men in the field. Not through books alone but by actually doing the work yourself, you get the knowledge you need to qualify for opportunities in UHF-TV SERVICING! Age is no barrier. Many T.C.I. students are over 40! Mail coupon for full facts, FREE Catalog and SAMPLE LESSON. Act NOW!

TELEVISION COMMUNICATIONS INSTITUTE
205 W. Wacker Dr., Dept. XP-1, Chicago 6, Ill.

MAIL NOW FOR FREE BOOKLET

THESE MEN LIKE YOURSELF SAY T. C. I. TRAINS YOU BEST!

"I've almost completed your course now, but have been servicing TV sets since almost the beginning of the course." E.R.M., Rhode Island

"Thanks to your course, jobs that used to take me several hours now take but a few minutes to complete." W.L.K., Wash.

"I like the easy way your lessons are presented. I'm very pleased with your course and have recommended it to a friend." L.R.S., Texas









TELEVISION COMMUNICATIONS INST.
Dept. XP-1, 205 W. Wacker Dr., Chicago 6, Ill.
YES! Rush full facts on UHF-TV training. Include FREE Catalog and Sample Lesson. I am not obligated. Salesman will not call.

Name..... Age.....
Address.....
City..... Zone..... State.....
 BEGINNERS: Check here for information on Pre-TV Radio Course.







**S & M
Data
Sheet**

Radio Symbols

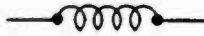
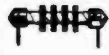
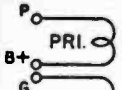
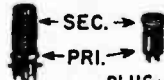



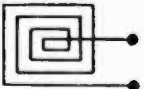







RESISTORS

	 COMPOSITION
FIXED RESISTOR CARBON COMPOSITION OR WIRE-WOUND	 WIRE WOUND
	 ADJ. WIRE
ADJ. OR TAP TYPE	
	 VOLUME CONTROL
VOLUME CONTROL OR WIRE POTENTIOMETER	 WIRE WOUND





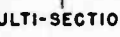





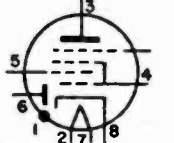

COILS (INDUCTANCE, ETC.)

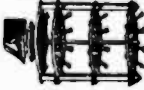
 R.F. CHOKE	
 PRI. PLATE WINDING OR ANT. COU- PLING	 ← SEC. → ← PRI. → PLUG-IN TYPE TYPE (AIR CORE)
 SEC. GRID WINDING ANT., R.F. & REGENERATIVE INDUCT- ANCE	
 LOUDSPEAKER	
 LOOP-ANTENNA	 MIDGET-FERRITE







CAPACITORS (CONDENSERS)

 VARIABLE	 GANG VARIABLE	 SINGLE	 GANG
 TRIMMER OR PADDER	 TRIMMER OR PADDER		
 FIXED	 PAPER OR MICA	 PAPER	 CAN ELECTRO- LYTICS
 ELECTROLYTIC	 MULTI-SECTION	 MICA	 TUBULAR

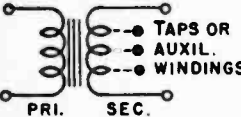
MISCELLANEOUS

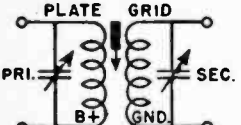
 NUMBERS INDICATE SOCKET CONNECTION	 MINIATURE TUBE	 OCTAL TUBE
 SWITCHES SELECTOR	 SINGLE SELECTOR	 TOGGLE OR MULTIPLE
 CRYSTAL DIODE	 DRY DISC RECTIFIER	 CRYSTAL DIODE RECTIFIER
 BROADCAST ANTENNAS TV, FM	 7 PIN MINI- TUBE SOCKET	
 GROUND	 8 PIN OCTAL TUBE SOCKET	

COIL & TRANSFORMERS

 PRI. SEC. TAPS OR AUXIL. WINDINGS	 AUDIO	 A.C. POWER
 PRI. PLATE GRID SEC. B+ GND. IRON CORE I.F. SHOWS ARROW SYMBOL. CAPACITOR TYPES SHOW BUILT-IN TRIMMERS	 R.F., ANT. & OSC. TYPES	 I.F. TRANS.
 IRON CORE CHOKE	 FILTER CHOKE	

IMPORTANT

All tube sockets are numbered (clockwise) starting at wide space on 7-pin tubes, and from keyway on octals. Socket No.'s read in consecutive order left to right from 1 to 7; 1 to 8, or 1 to 9 depending upon number of tube elements.

Useful Tables and Formulas

Compiled by Thomas A. Blanchard

STANDARD RESISTOR VALUES

• Table A, below, lists all *carbon type* resistors manufactured in the United States according to RTMA (Radio-Television Manufacturers Association) and JAN (Joint Army-Navy) Standards. The bold figures show the 10% accuracy values that are becoming the preferred electronic standard. For example, a circuit may call for a resistor of 50,000 ohms. However, noting chart, the nearest standard 10% value today is 47,000 ohms.

Except in cases where a very low ohms value is called for, any resistance under 500 ohms, it is usually safe to use the nearest value shown in bold face type in Table A.

TABLE A—STANDARD RESISTANCE VALUES

All values in OHMS					MEG OHMS			
1.0	10	100	1,000	10,000	100,000	0.1	1.0	10.0
1.1	11	110	1,100	11,000	110,000	0.11	1.1	11.0
1.2	12	120	1,200	12,000	120,000	0.12	1.2	12.0
1.3	13	130	1,300	13,000	130,000	0.13	1.3	13.0
1.5	15	150	1,500	15,000	150,000	0.15	1.5	15.0
1.6	16	160	1,600	16,000	160,000	0.16	1.6	16.0
1.8	18	180	1,800	18,000	180,000	0.18	1.8	18.0
2.0	20	200	2,000	20,000	200,000	0.2	2.0	20.0
2.2	22	220	2,200	22,000	220,000	0.22	2.2	22.0
2.4	24	240	2,400	24,000	240,000	0.24	2.4	24.0
2.7	27	270	2,700	27,000	270,000	0.27	2.7	27.0
3.0	30	300	3,000	30,000	300,000	0.3	3.0	30.0
3.3	33	330	3,300	33,000	330,000	0.33	3.3	33.0
3.6	36	360	3,600	36,000	360,000	0.36	3.6	36.0
3.9	39	390	3,900	39,000	390,000	0.39	3.9	39.0
4.3	43	430	4,300	43,000	430,000	0.43	4.3	43.0
4.7	47	470	4,700	47,000	470,000	0.47	4.7	47.0
5.1	51	510	5,100	51,000	510,000	0.51	5.1	51.0
5.6	56	560	5,600	56,000	560,000	0.56	5.6	56.0
6.2	62	620	6,200	62,000	620,000	0.62	6.2	62.0
6.8	68	680	6,800	68,000	680,000	0.68	6.8	68.0
7.5	75	750	7,500	75,000	750,000	0.75	7.5	75.0
8.2	82	820	8,200	82,000	820,000	0.82	8.2	82.0
9.1	91	910	9,100	91,000	910,000	0.91	9.1	91.0

Note: Values below one ohm are available for precise instrument or laboratory work. They are not ordinarily needed by the radio or TV experimenter.

10% accuracy resistors are less costly and can be used for most applications. All values may not be available from all manufacturers or radio supply houses.

It will be noted that resistors are standardized in *units, tens, hundreds, thousands . . .* reading across table. This simplifies reading of color codes. While standard values stop at 22 megohms, IRC and certain other resistor makers supply values up to 200 megohms for laboratory use. Special resistors may cost 100 times a standard value due to technically skilled labor required in calibration as against production-line labor.

RESISTORS IN MULTIPLE

• *Series.* Any number of resistors of identical wattage may be connected in series to obtain a desired resistance value. If wattage ratings are mixed, the total resistance will handle as much

FORMULA: $R_1 + R_2 + R_3 = \text{RESISTANCE TOTAL}$
 EXAMPLE: $15000 + 47000 + 22000 = 84000 \text{ OHMS}$



as the lowest wattage resistor in the "string."

Parallel. Identical resistors in parallel increase the wattage rating of the total resistance. At the same time the total number of resistors becomes the divisor for the unit combination.

(Using three 4700-ohm, 1-watt units.)

FORMULA: $R = \frac{R}{\text{NO. OF RESISTANCES}} = \text{TOTAL RESISTANCE}$

EXAMPLE: $\frac{4700}{3} = 1567 \text{ OHMS}$

FORMULA: $P \times \text{NO. OF RESISTANCES} = \text{TOTAL WATTAGE (POWER)}$

EXAMPLE: $1 \times 3 = 3 \text{ WATTS}$



Mixed value resistors connected in parallel employ this formula for multiples of two resistors only: (Using a 4700 and 3300 ohm 1-watt resistor.)

FORMULA: $\frac{R_1 \times R_2}{R_1 + R_2} = \text{TOTAL RESISTANCE}$

EXAMPLE: $\frac{4700 \times 3300}{4700 + 3300} = \frac{155100}{8000} = 1940 \text{ OHMS (APPROX)}$

Mixed resistances in parallel do not (theoretically) double in current carrying capacity (wattage). However, if above 4700 and 3300-ohm resistors were each rated 1-watt, the combination would handle almost two watts. If a large difference exists between two values, total wattage through circuit should not greatly exceed rating of lowest wattage single unit.

For multiple mixed parallel combinations, reduce resistors in pairs with above formula until arriving at final resistance. There are formulas

STANDARD RTMA TRANSFORMERS CODE

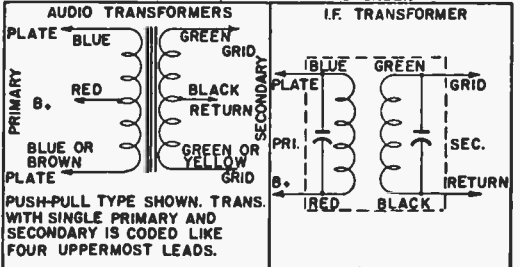
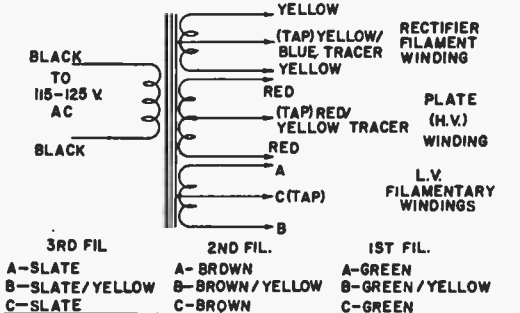

for multiple mixed resistor combinations, but they are much more complicated than simple reduction.

COLOR CODE CHART—FOR RESISTORS AND CAPACITORS

Color Dot A (mmf.) Color Band A (ohms)	Color Dot B (mmf.) Color Band B (ohms)	Color Dot C (mmf.) Color Band C (ohms)
Black.....0	Black.....0	
Brown.....1	Brown.....1	Brown.....Add 1 zero
Red.....2	Red.....2	Red.....Add 2 zeros
Orange.....3	Orange.....3	Orange.....Add 3 zeros
Yellow.....4	Yellow.....4	Yellow.....Add 4 zeros
Green.....5	Green.....5	Green.....Add 5 zeros
Blue.....6	Blue.....6	Blue.....Add 6 zeros
Violet.....7	Violet.....7	Violet.....Add 7 zeros
Gray.....8	Gray.....8	Gray.....Add 8 zeros
White.....9	White.....9	White.....Add 9 zeros

Example:
Band A is Yellow
Band B is Violet
Band C is Orange
Resistor will be 47,000 ohms.

Example:
Dot A is Red
Dot B is Green
Dot C is Brown
Capacitor is 250 mmf.

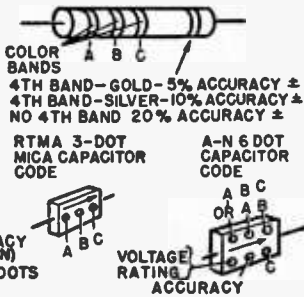

TABLE B—DECIMAL EQUIVALENTS

1/64 .0156	1/4 .2500	1/2 .5000	3/4 .7500
1/32 .0312	17/64 .2656	33/64 .5156	49/64 .7656
3/64 .0469	9/32 .2812	17/32 .5312	25/32 .7812
	19/64 .2969	35/64 .5469	51/64 .7969
1/16 .0625	5/16 .3125	9/16 .5625	13/16 .8125
5/64 .0781	21/64 .3281	37/64 .5781	53/64 .8281
3/32 .0938	11/32 .3438	19/32 .5938	27/32 .8437
7/64 .1094	23/64 .3594	39/64 .6094	55/64 .8594
1/8 .1250	3/8 .3750	5/8 .6250	7/8 .8750
9/64 .1406	25/64 .3906	41/64 .6406	57/64 .8906
5/32 .1562	13/32 .4062	21/32 .6562	29/32 .9062
11/64 .1719	27/64 .4219	43/64 .6719	59/64 .9219
3/16 .1875	7/16 .4375	11/16 .6875	15/16 .9375
13/64 .2031	29/64 .4531	45/64 .7031	61/64 .9531
7/32 .2188	15/32 .4688	23/32 .7183	31/32 .9688
15/64 .2344	31/64 .4844	47/64 .7344	63/64 .9844

TABLE C—METRIC LENGTHS TO INCHES

2.54 Centimeters = 1 Inch	
1 Millimeter (unit) mm	= .03937 inch
10 Millimeters = 1 Centimeter (cm)	= .3937 inch
10 Centimeters = 1 Decimeter	= 3.937 inches
10 Decimeters = 1 Meter (m)	= 39.37 inches

COMPUTING VOLTAGE-DROPPING RESISTOR FOR SERIES WIRED TUBES

• Small ac-dc radios are operated without use of a step-down filament transformer by wiring all tube filaments (heaters) in series. Tubes in a modern 5-tube set have individual filaments which total 121 volts, requiring no voltage-drop.

Sets with 4 or less tubes may require a resistor to make up the difference between their total and line voltage. Most miniature tubes and GT types draw .3 amp. if 6-volt filament type; or .150 amp. if 12-volt filament type.

To calculate voltage drop, add up total voltage of tubes in string (all must have same current rating as determined by checking in a tube man-

ual). Subtract the resulting figure from your power line voltage. Now divide the tube current into the voltage difference. The answer will be the value of the voltage dropping resistor in ohms. For example:

Line voltage 120 volts
Three 12 v. .150 amp. tubes total 36 volts
Voltage drop 84

R = Resistance in ohms
E = voltage in volts
I = current in amperes

$$R = \frac{E}{I} = \frac{84}{.150} = 560\text{-ohm resistor required}$$

To determine wattage rating use formula $W = I^2 R$ or $.150 \times .150 \times 560 = 12.60$ watts.

Since a 560-ohm, 12.60-watt resistor is not available, select next size; in this case 600 ohms rated at 20 watts.

FINDING THE UNKNOWN

Volts —E—	Milliamperes (Ma.) —I—	Ohms —R—	Watts —W—
Known	Known	1000 x volts milliamperes	Volts x milliamps 1000
Known	1000 x volts Ohms	Known	Volts x volts Ohms
Known	1000 x watts volts	volts x volts watts	Known
MA. x Ohms 1000	Known	Known	MA. x MA. x Ohms 1,000,000
1000 x watts MA.	Known	1,000,000 x watts MA. x MA.	Known
$\sqrt{\text{ohms x watts}}$	1000 $\sqrt{\text{watts}}Ohms$	Known	Known

Circuit component requirements are quickly established with this table so long as any two items in columns are known. Then simply read across the proper row for formulas that will provide the unknown information.

OHM'S LAW AND DIRECT CURRENT RELATIONS

(E = IR or Volts = Amperes x Ohms)

(E) VOLTS = IR or $\frac{W}{I}$ or \sqrt{RW} (I) AMPS. = $\frac{E}{R}$ or $\frac{W}{E}$ or $\sqrt{\frac{W}{R}}$

(R) OHMS = $\frac{E}{I}$ or $\frac{W}{I^2}$ (W) WATTS = EI or I²R or $\frac{E^2}{R}$

TABLE D—CONVERTING ELECTRONIC UNITS OF MEASURE

Amperes	× 1,000,000	= Microamperes
Amperes	× 1,000	= Milliamperes
Cycles	× .000,001	= Megacycles
Cycles	× .001	= Kilocycles
Farads	× 1,000,000,000,000	= Micro-microfarads
Farads	× 1,000,000	= Microfarads
Henries	× 1,000,000	= Microhenries
Henries	× 1,000	= Millihenries
Kilocycles	× 1,000	= Cycles
Kilovolts	× 1,000	= Volts
Kilowatts	× 1,000	= Watts
Megacycles	× 1,000,000	= Cycles
Microfarads	× .000,001	= Farads
Microfarads	× 1,000,000	= Micro-microfarads
Microhenries	× .000,001	= Henries
Microvolts	× .000,001	= Volts
Micro-microfarads	× .000,000,000,001	= Farads
Milliamperes	× .001	= Amperes
Millihenries	× .001	= Henries
Millivolts	× .001	= Volts
Ohms	× .000,001	= Megohms
Ohms	× 1,000	= Milliohms
Volts	× 1,000,000	= Microvolts
Volts	× 1,000	= Millivolts
Watts	× 1,000	= Milliwatts
Watts	× .001	= Kilowatts

This table is extremely versatile in that it may be used forward and backward. For Example: amperes x 1,000,000 = microamperes. Or 0.25

amp. x 1,000,000 = 250,000 microamperes. Reading the table from right to left, note that a micro-ampere is a millionth part of an ampere; a milli-ampere is a thousandth part of an ampere.

The center "multiplier" column is expressed both in whole numbers and decimals. This is done for mathematical simplicity.

When reading a decimal "multiplier" from right to left, it is read as a whole number. For example: Watts x .001 = Kilowatts. Or 10 watts x .001 = .01 (1/100th part of a kilowatt.) Now reading right to left, Kilowatt equals 1000 watts. The decimal .001 (1/1000th) is read as a whole number, or *one thousand*.

TABLE E—ELECTRONIC & ELECTRICAL ABBREVIATIONS

A.C., a-c	Alternating Current
A.F.	Audio Frequency
AM	Amplitude Modulation. Method of transmission used by standard long and short-wave stations; also for sending TV pictures
A.V.C.	Automatic Volume Control
C (cp.)	Capacitance in farads; microfarads, or micro-microfarads
c.p.s.	Cycles per second
db	Decibel. A unit of sound measurement
D.C., d-c	Direct Current
FM	Frequency Modulation. Method of sound transmission used by high-frequency broadcasters (including TV sound)
E, e	Symbol denoting voltage
f	Frequency—kilocycles or megacycles
emf, e	Electromotive force
H.F.	High-frequency as used for standard shortwave, FM and TV sound and picture transmission.
H.V.	High-voltage (usually with regard to TV circuits)
Hy, h	Henry, unit for measuring coil inductance
I	Electrical symbol for current (amperes, milliamperes, microamperes)
I.F., i.f.	Intermediate Frequency (or transformers as employed in superheterodyne circuits)
K (M)	Kilo from the Greek meaning one thousand. M also a prefix for one thousand, but becoming obsolete
L	Electrical symbol for inductance
L.V.	Low-voltage (tube filaments and TV voltages under 360v.)
ma	Milliamperes; 1/1000th of an ampere
Meg, MΩ	One megohm (1-megohm = one million ohms)
mfd, μfd	Microfarad
mmf, mmfd.	Micro-microfarad
Mil	One-thousandth part. Used as prefix in voltage and current. Also a measurement of wire diameters
mu	Amplification factor of vacuum tubes
R	Symbol for electrical resistance (ohms)
R.F.	Radio Frequency
RMS, r.m.s.	Root means square as employed in alternating current calculation
SG (g ₂)	The high potential valve element in a vacuum tube; often called the screen grid
SW (sw)	Switch or shortwave
TRF, t.r.f.	Tuned Radio Frequency. Often with reference to a low sensitivity-high fidelity type radio circuit
UHF	Ultra-High Frequency
VHF	Very-High Frequency
wf, λ	Wavelength
X	Electrical symbol for reactance (Opposing force to a-c)
Z	Electrical symbol for impedance (Total a-c opposition)

GREEK SYMBOLS

Ω	Ohms (from omega) "O"
λ	Wavelength (from lambda) "L"
μ	Mu or micro- (Greek letter M)
π	Pi or 3.14 (Graek letter P)

Greek Alpha (A); Beta (B), Gamma (C) denote types of radio-active waves.

Wire Screen Serves as Signal-Booster for Loop

• To increase signal pick-up when a portable receiver is being used in a steel building, connect a regular outdoor antenna to some large insulated metal surface in the room, such as to a copper screen placed under the rug, or to a piece of screen tacked under the table on which the receiver is most often used.

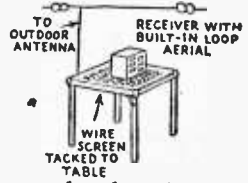

Handy Wire Peeler

• A piece of spring steel or an old hacksaw blade with the teeth filed off, measuring 7" long by 1/2" in width, makes a handy wire peeler.

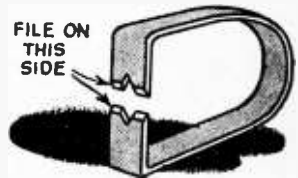

Cut a "V" in each end 1/4" long and file on one side only of the "V" notch, tapering it like a wood chisel. Emery cloth all burrs and bend the spring steel or hacksaw blade into a horseshoe shape. When wire is to be peeled, slight pressure will cause the jaws to cut through the insulation, and by giving the peeler a half turn, the insulation is cut and the wire bared.—BARNEY M. JENSEN.

Four Lamp Traffic Light

• A traffic light that operates with only four lamps, eliminates the amber warning signal, and needs no time switches, has been patented by Frank T. Powers of Glen Cove, New York. The essentials—two pairs of lamps mounted on shaft at right angles, on shaft turned at proper time intervals by motor mechanism in base. Each lamp is enclosed in parabolic reflector and covered by red or green lens or filter.

Pencil Clip Secures Screw to Driver

• A screw-holding screw driver is easily made by adding an ordinary metal pencil clip to the driver, as shown, so that it will hold the head of the screw while it is being placed



in position for driving. It will probably be necessary to bend the arms of the clip with pliers so that it will grip the smaller driver shaft. Pull clip back out of way when not in use.—K. M.

How to Understand RADIO and TELEVISION BETTER!

If you feel the need of a more complete understanding of the basic principles of radio or television, here are just the books you need to answer those puzzling questions. Every book is written by an authority and written so you can understand it. Our editors have reviewed hundreds of books on radio, electronics and television in order to make up this list of recommended titles. You can buy these books with full assurance that they are the BEST books on the subject. In ordering, list catalog number and title, enclosing remittance with coupon. We guarantee complete satisfaction or your money refunded. Order Today!

UNDERSTANDING RADIO, by Watson, Welch and Eby

Written for individuals who have little or no technical knowledge but wish to know the fundamentals of radio theory and servicing. Explains clearly every technical term as soon as it is used. Simple experiments help the reader to learn by doing as well as by reading. Presents the fundamentals of electrical and radio theory one by one in a logical sequence. 732 pages.

Order 52R57.....\$6.50

INTRODUCTORY RADIO: THEORY AND SERVICING by Hicks

Fundamentals of radio operation, the methods and techniques of radio repair work, explained and described in simple, easy-to-understand form. Utilizes the "learn by doing" system, explaining the tools and equipment used, where and how the various parts operate, and the theory behind each stage. Describes both the "how" and "why" of any service problem. 384 pages.

Order 52R58.....\$4.50

ELEMENTS OF RADIO SERVICING by Marcus and Levy

Elementary text on principles and practice of radio servicing, with emphasis on service theory and procedures rather than on design. Shows, step by step, how to find and remedy nearly every type of radio receiver trouble. Details the exact methods to use in making a quick check for normal operation, for functioning of component parts, etc. 474 pages.

Order 52R59.....\$5.25

TELEVISION SERVICING by Heller and Shulman

Guide to servicing of television receivers, written in a clear and straightforward manner, free of ambiguous technical terminology. Suitable for any reader having only an initial understanding of radio fundamentals. Covers the operation and servicing of every section of the television receiver; problems concerning antenna installations are described and solutions are presented. 520 pages.

Order 52R60.....\$6.50

BASIC TELEVISION by Grob

Supplies a comprehensive course for servicemen and technicians, filling the gap between advanced engineering tests and simplified but often incomplete books. Presents not only the basic techniques but the more difficult problems of television in so simple a form that beginners can understand them. 592 pages.

Order 52R61.....\$7.50

TELEVISION ENGINEERING by Fink
Gives working knowledge of the complete television system—prepares the reader for technical work in designing television systems, operating television equipment or understanding the details of receiving equipment. The whole television process, from studio to receiver, is covered; describes the design, operation, and use of television equipment. 721 pages.

Order 52R62.....\$8.50

TELEVISION PRINCIPLES by Dome
Covers television engineering from the origin of the picture signal to reproduction of the picture at the receiver, with concise explanations, useful charts, tables, and schematic diagrams to simplify understanding. Provides a thorough background of the principles of television transmitter and receiver design. 281 pages.

Order 52R63.....\$5.50

QUESTIONS AND ANSWERS IN TELEVISION ENGINEERING by Rabinoff and Wolbrecht

Gives practical, detailed answers to hundreds of questions concerning all phases of television engineering. Typical mathematical problems are included, together with Government laws, standards and regulations. Appendix provides the proposed changes in standards and rules for commercial television in the ultra-high frequency channels. 300 pages.

Order 52R64.....\$5.50

PRINCIPLES AND PRACTICE OF RADIO SERVICING by Hicks

Shows how to install, test and repair radio receivers, giving not only instructions in all the servicing procedures, but also plain treatment of the theory of electricity and radio needed for most effective approach to servicing problems. Written in excellent self-study style for servicemen who want to improve their skill and readers who want to learn this practical field. 391 pages.

Order 52R65.....\$4.50

PRINCIPLES OF RADIO by Henney and Richardson

This book is designed for the reader with little background in radio who wants to know the basis upon which radio communication exists. The major emphasis is on the basic radio circuits. Operating ranges of typical equipment are given where practicable. Step-by-step examples have been included to illustrate the more difficult types of computations.

Order 82R81.....\$5.50

RADIO ENGINEERING HANDBOOK by Henney

Offers a great store of constantly needed information covering all fields and aspects of radio engineering—arranged in concise, easy-to-get-at form. Material has been chosen for its importance to the practical designer. Emphasis is placed on design data, presented in a profusion of tables, charts, equations, formulas and diagrams, rather than descriptive matter subject to frequent change. 119 pages.

Order 52R66.....\$10.00

HOW TO PASS RADIO LICENSE EXAMINATIONS by C. E. Drew

This new third edition has been completely revised to include the sweeping changes made recently in the F.C.C. examinations. New questions have been added, old questions eliminated, and more complete answers given to many of the questions which have not been changed.

Order 82R80.....\$10.00

FUNDAMENTAL RADIO EXPERIMENTS by R. C. Higggy

This book describes 32 basic experiments or tests in electricity, electronics and radio, and shows you how to do them. Each test includes a full explanation of principles involved, as well as procedure to be followed in the laboratory.

Order 82R82.....\$2.25

ENCYCLOPEDIA ON CATHODE-RAY OSCILLOSCOPES AND THEIR USES by John F. Rider and Seymour D. Usian

The only book of its kind that tells you all you should know about an oscilloscope. This text fully and clearly describes the device, its construction and its capabilities. It explains what a scope is, what it can do, and how it is used. The authors thoroughly cover the applications of the oscilloscope in servicing, engineering and research, and offer thousands of time-saving, labor-saving references, charts, waveforms, etc. All oscilloscopes produced during the past ten years, a total of more than 70 different models, are accurately described, with specifications and wiring diagrams. If you are planning to buy a scope, this book will help you select the type best suited to your needs. If you already own one, it will show you how to increase your instrument's usefulness and value to you. We guarantee this book will save and earn many, many times its cost to you! Half a million words. Easy to read. 3,000 illustrations. 8" x 11". 992 pages.

Order 65R67.....\$9.00

VACUUM-TUBE VOLTMETERS, by John F. Rider

All the facts on the many types of vacuum-tube voltmeters are here—this is the only book devoted exclusively to the subject! Especially valuable are the step-by-step procedures for applying the device to many uses. The new edition is thoroughly revised and completely rewritten. It contains a new chapter on commercial VTVM's, covering more than 40 commercial VTVM's with accompanying schematics and parts values, and a new chapter on probes for D-C and R-F. Factory maintenance instructions are included for the models discussed as well as general maintenance information. 21215 illustrations. 5 1/2" x 8 1/2".

Order 65R68.....\$4.50

TV PICTURE PROJECTION AND ENLARGEMENT by Allan Lytel

The story behind TV picture by viewing lenses and by projection systems is important to every serviceman. Read this text, which explains "how" and "why," and you will find adjustments of these receivers can be simple and rapid. It is a combination of theory and dollar-making, time-saving practice! 40 illustrations. 192 pages.

Order 65R72.....\$3.30

FM TRANSMISSION AND RECEPTION
by Rider and Usian

All your questions about new developments in f.m. are answered in this text. The latest functions and applications of f.m. are thoroughly and clearly discussed. Transmitting and receiving antennas are covered as well as various types of receivers, including television, their functioning and servicing. Radio servicemen, radio amateurs, engineers, students will find this an indispensable reference volume combining theory and practice. You will learn the basic principles underlying the operation of the complete f-m transmitter as well as the receiver. Both narrow-band and wide-band transmitters being manufactured today are discussed. Says ELEC-TRONIC ENGINEERING: "Its 400 pages represent good value for money..." EXTRA: Review Questions at the end of each chapter. 460 pages. 5 1/2" x 8 1/2". Illustrated.

Order 65R83.....\$4.95

TV AND OTHER RECEIVING ANTENNAS (Theory & Practice) by Arnold B. Bailey

This book answers the questions of service technicians, engineers, students and teachers about receiving antennas. Much of the data in this authoritative, up-to-the-minute text has never before been published anywhere! Data pages on approximately 50 different basic types aid analysis and preselection of antennas. The advantages and disadvantages of each type are discussed, and suggestions are given concerning antenna requirements in various reception areas. Mathematics is translated into tables, charts, and graphs, making the book easily understandable and highly readable. We guarantee it will answer all your questions. 5 1/2" x 8 1/2". 310 illustrations. 606 pages.

Order 65R69.....\$6.60

TV AND ELECTRONICS AS A CAREER
by Ira Kamen and Richard H. Dorf

Here's your guidebook to an interesting and profitable career in the electronics industry. Experts tell you what opportunities are offered, how to prepare yourself for them, how to go about getting the job you want. This is no generalized or romanticized picture—this is the actual story told by men who know. TV AND ELECTRONICS AS A CAREER is the only definite text that gives all the facts to the newcomer preparing for a career and to the man already in electronics who wants to switch to another field of specialization within the industry. 130 illustrations. 5 1/2" x 8 1/2". 326 pages.

Order 65R78.....\$4.95

TV MASTER ANTENNA SYSTEMS
by Ira Kamen and Richard H. Dorf

A practical working manual dealing with the installations, maintenance, usage, and merchandising of TV master antenna systems—solves all problems from start to finish. Virtually all amplified and non-amplified systems are discussed. Written in a clear style that strikes a balance between elementary and technical, it is ideally suited to those technically trained, and also completely meets the needs of the non-technical man. This is the only available source book of its kind. 5 1/2" x 8 1/2". 234 illustrations. 368 pages.

Order 65R71.....\$5.00

RECEIVING TUBE SUBSTITUTION GUIDE BOOK by H. A. Middleton

Answers all tube problems by listing 2,500 radio-television tube substitutions in numerical sequence with accompanying wiring instructions, original and substitute tube socket illustrations. You will find information to help you turn out jobs that would otherwise remain on the shelf because of lack of proper tubes. 224 pages. 8 1/2" x 11".

Order 65R73.....\$3.00

RADIO OPERATOR'S LICENSE Q & A MANUAL by Milton Kaufman

Systematically listed are the questions and answers to pass FCC exams plus a FOLLOW-THROUGH discussion of the answer, so necessary for a complete understanding of the technical question. Abundant illustrations make difficult technical questions picture-clear. Not simply an optional text, but an indispensable reference volume for student, operator, and radio amateur. It is up-to-date in all respects as of the August 1951 publication date. Based on the Government Study Guide and supplementary FCC releases, the volume offers valuable appendices (small vessel direction finders and automatic alarm) never before available in a book of this type. You will find yourself constantly referring to this complete, comprehensive handbook for a thorough review of essential theory, as well as for a refresher for advancement in the field. 5 1/2" x 8 1/2". 243 illustrations. 734 pages.

Order 65R74.....\$6.60

SERVICING BY SIGNAL TRACING

Learn how to locate defects in any type of receiver—radio, television, public system, etc. The text explains what happens to the signal from the instant it enters the antenna post of a set until it energizes the loud speaker. Signal tracing enables you to test the components of a set by checking their functions. Repair receivers faster, easier, and more accurately by using the information contained here. 188 illustrations. 360 pages.

Order 65R75.....\$4.00

BROADCAST OPERATOR'S H A N D - BOOK by Harold E. Ennes

Completely revised and brought up to date, the text deals with the practical considerations of radio broadcasting and its equipment. The first four parts of the book cover actual operating practice in control rooms, the master control, remote controls, and the transmitter; the fifth and sixth parts discuss technical data for operators and technicians, including vital preventive maintenance instructions. The author, a practicing broadcast operator, takes you inside and outside the studio, while explaining all the why's and wherefore's of daily studio routine. Written in the operator's language, the text is intended not only for students of broadcasting techniques, but veteran operators also, who wish to keep abreast of current practices in the field. 226 illustrations. 5 1/2" x 8 1/2". 440 pages.

Order 65R77.....\$5.40

TV TROUBLESHOOTING & REPAIR GUIDE BOOK by John R. Rider and Robert Middleton

A new, practical, easy-to-use book for the TV service technician. It tells you how to spot receiver troubles and correct them. Contains factual information right from the manufacturer, things you must know to be a TV troubleshooting and repair expert. The contents include: explanation of split-circuit and intercarrier receivers, circuit variations and how they affect operating waveforms, simplified TV receiver troubleshooting by scope and picture tube screen display analysis, remedies for circuit troubles, rapid methods of alignment and recognition of alignment problems. Not a theory book—but a practical, down-to-earth troubleshooting and repair guide. 8 1/2" x 11". Durably bound. 200 pages.

Order 65R79.....\$3.90

TV INSTALLATION TECHNIQUES
by Samuel Marshall and George Westinghouse

The most practical book of its kind, this text is designed to help you make the best possible installation and eliminate return calls. It offers complete information on all the mechanical and electrical considerations of TV installation. Wherever and whenever an installation is a problem, this authoritative book will help you. It puts at your fingertips accurate data on receiver adjustments in the home, municipal regulations governing the installation of TV antennas and masts in all the major TV areas in the United States. You get the facts about such matters as ice loading and wind surface. Mounting requirements, whether for a short chimney-attached mast or an 80-foot tower, are explained thoroughly. 5 1/2" x 8 1/2". 270 illustrations. 360 pages.

Order 65R70.....\$4.50

UNDERSTANDING VECTORS AND PHASE IN RADIO by John F. Rider and Seymour D. Usian

A shorthand method to easier understanding of radio theory, the text is written for every man in radio and electronics who has not had the advantage of technical training. Vectors are the engineer's shorthand—a picturegraph adopted to eliminate mathematical and complex waveform presentations; and understanding of which is necessary in following developments in FM and television. Numerous drawings and diagrams illustrate the text. The concluding chapter analyzes everyday radio circuit problems, and in so doing clarifies them. 160 pages.

Order 65R76.....\$1.89

CLIP AND MAIL THIS COUPON

SCIENCE AND MECHANICS MAGAZINE

450 East Ohio Street, Dept. R-152, Chicago 11, Illinois

Enclosed is \$ _____ for which send me the following books, delivery charges prepaid, under your guarantee of complete satisfaction or my money refunded.

CATALOG NO.	TITLE	PRICE
_____	_____	_____
_____	_____	_____
_____	_____	_____
_____	_____	_____
_____	_____	_____

(Sorry, but we cannot fill C.O.D. orders)

NAME _____

ADDRESS _____

CITY, ZONE & STATE _____

NOW AT HOME IN SPARE TIME!
Get the "BASICS" you've missed!



LEARN RADIO
plus
TELEVISION
AND ELECTRONICS

LEARN IT THOROUGHLY! FROM AMERICA'S MOST COMPLETE HOME TRAINING SCHOOL!

You Get All The Parts - Even Tubes - for this modern Superheterodyne Receiver - and lots of other equipment. And you get to keep it!

Let **NATIONAL SCHOOLS**—the famous resident-training school founded in 1905—train you as you want to be trained. One of the largest schools of its kind, National is located in Los Angeles—center of Radio-Television world!



You learn from lessons prepared by men who are successful Radio and Television technicians.



BIG FREE BOOK TELLS YOU HOW

Page after page—in **COLOR**—tells you everything you want to know! Mail the coupon. Get yours—today!

PLUS A FREE SAMPLE LESSON!

You Train at Home—In Your Spare Time!

National Schools Shop-Method Home Training gives you basic and advanced instruction in all the phases of Radio-Television-Electronics.

You learn *fast* from hundreds of diagrams and pictures. All instructions are written by experienced technicians who work in Radio and TV every day. All instructions have been developed and tested in National Schools' own big labs and studios, which are equipped with the latest RCA equipment. No wonder this National Schools course is so up-to-date, practical, easy!

We Teach You How To Make Welcome Extra Money—While You Learn!

Many National Schools students—men like you—make plenty of extra dollars in spare time! Fixing neighbors' radios and appliances—and other ways we teach you. You can earn while you learn!

LOOK! WE SEND YOU ALL THESE PARTS!



With famous National Schools Shop-Method Home Training, you learn *by doing*—the easy, practical, interesting way. The way you want to learn. We send you many parts—all of modern professional quality. You do lots of practical experiments. You advance day by day, step by step. The free book tells you all about it. Answers all your questions. Use the coupon. And do it now—while you're thinking of it.

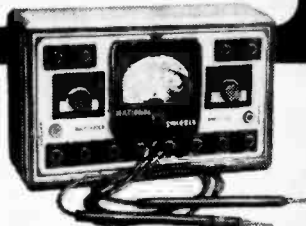

ONLY NATIONAL SCHOOLS GIVES YOU THIS PROFESSIONAL MULTI-TESTER!

You get this amazing new testing instrument! Ready to use! Simple to operate. Accurate and dependable. And—it's light enough to carry around—so you can use it at home or on service calls.

HERE ARE ONLY A FEW OF THE GOOD-PAYING JOBS YOU CAN CHOOSE!

- Radio Station Engineer
- Inspector Technician
- District Service Manager
- Service Specialist
- Aircraft Radio Inspector
- Special Gov't Positions
- Own Your Own Repair Shop
- Sound Truck Operator

Attention! Men Going into the Service Soon!

With this training you can get into *special* service classifications—with higher pay and grade—fast!

FREE SERVICE FOR GRADUATES!

National Schools helps you find your place in the field of your choice. We help you start toward the good pay you've dreamed of. Get the training you should have. Mail the coupon for the facts—today.

NATIONAL SCHOOLS

LOS ANGELES 37, CALIFORNIA • ESTABLISHED 1903
 In Canada: 193 E. Hastings St., Vancouver, B.C.

Today's Shortage of Trained Technicians

Creates Chance of a Lifetime For You! Think of it! With guided missiles, radar, and other electronic devices so important to defense! And with over 90,000,000 radios, over 12,000,000 TV sets. With more than 3100 radio stations...over 100 TV stations—and more building every day. Men are wanted in Radio-Television-Electronics—America's fastest-growing field—act quickly!

Job Security! Big Money! For YOU! In Today's Expanding Industries!

National Schools graduates—men just like you—are earning good money all over the country. Why not you? *Enjoy* your work—rather than having to drag along in just any old job. Mail coupon today—find out how easy it is.

National Schools Has Trained 1000's of Successful Men! Why Not YOU?

In almost every state—and many foreign countries—National Schools graduates are filling big jobs with national companies. Or running their own successful businesses. National Schools Shop-Method Home Training is *complete* training. You can take advantage of today's great opportunities in Radio-Television-Electronics—fast.

**DON'T PUT IT OFF!
 GET THE BIG SALARY YOU HAVE ALWAYS WANTED!**

MAIL THIS COUPON TODAY—WITHOUT FAIL!

NATIONAL SCHOOLS, Dept. KK-102
 4000 South Figueroa Street
 Los Angeles 37, California

Mail in envelope or paste on postal card

Mail me FREE the book mentioned in this ad. Also a free sample lesson. I understand no salesman will call on me and that there is no obligation.

NAME _____ AGE _____

ADDRESS _____

CITY _____ ZONE _____ STATE _____

Vets! Check here if released from service less than 4 years ago.



TRAIN FASTER—TRAIN BETTER—TRAIN EASIER
IN 10 MONTHS—OR LESS—FOR
RADIO-TELEVISION
 Our 21st Year Training Men for Greater Incomes and Security in Radio-Television

I SEND YOU 18 BIG KITS
 of Radio-Television parts and equipment. Much of your training will be actual construction and experimentation—the kind of truly PRACTICAL instruction that prepares you for your Radio-Television career.



Frank C. Sprayberry
 President
 Sprayberry Academy
 of Radio

NEW! NO OBLIGATION PLAN

You Have No Monthly Payment Contract to Sign Pay For Your Training as You Earn and Learn

You can get into Radio-Television, today's fastest growing big money opportunity field, in *months* instead of years! My completely new "package unit" training plan prepares you in as little as 10 months or even less! *No monthly payment contract to sign—thus NO RISK to you!* This is America's finest, most complete, practical training—gets you ready to handle any practical job in the booming Radio-Television industry. Start your own profitable Radio-Television shop . . . or accept a good paying job. I have trained hundreds of successful Radio-Television technicians during the past 21 years—and stand ready to train you, even if you have no previous experience! Mail coupon and get all the facts—FREE!



Valuable Equipment Included With Training

The new Sprayberry "package" plan includes many big kits of genuine, professional Radio-Television equipment. You perform over 300 demonstrations, experiments and construction projects. You build a powerful 6-tube 2-band radio set, multi-range test meter, signal generator, signal tracer, many other projects. All equipment and lessons are yours to keep . . . you have practically everything you need to set up your own profitable Radio-Television service shop.

Earn Extra Money While You Learn!

All your 10 months of training is IN YOUR HOME in spare hours. Keep on with your present job and income while learning. With each training "package" unit, you receive extra plans and "Business Builder" ideas for spare time Radio-Television jobs. New television stations everywhere, open vast new opportunities for trained Radio-Television Technicians—and those in training. If you expect to be in the armed forces later, there is no better preparation than practical Sprayberry Radio-Television training.

YOU BUILD the Television set and the powerful superact radio receiver shown above IN ADDITION to the other test units shown here. (Many are not illustrated.)

Approved for Veterans under the G. I. Bill

SPRAYBERRY ACADEMY OF RADIO 111 NORTH CANAL ST. Dept. 420, Chicago 6, Ill.

MAIL COUPON TODAY! NO OBLIGATION

SPRAYBERRY ACADEMY OF RADIO, Dept. 420
 111 North Canal St., Chicago 6, Ill.

Please rush to me all information on your 10-MONTH Radio-Television Training Plan. I understand this does not obligate me and that no salesman will call upon me. Be sure to include 3 books FREE.

Name..... Age.....
 Address.....
 City..... Zone..... State.....

I invite you to get all the facts — FREE TO YOU 3 BIG RADIO-TELEVISION BOOKS

Rush coupon for my three big Radio-Television books: "How to Make Money in Radio-Television" PLUS my new illustrated Television Bulletin PLUS an actual sample Sprayberry Lesson — ALL FREE. No obligation and no salesman will call. Mail coupon NOW!



THESE MEN ARE GETTING PRACTICAL TRAINING

IN ELECTRICITY

—ELECTRONICS

On Real:

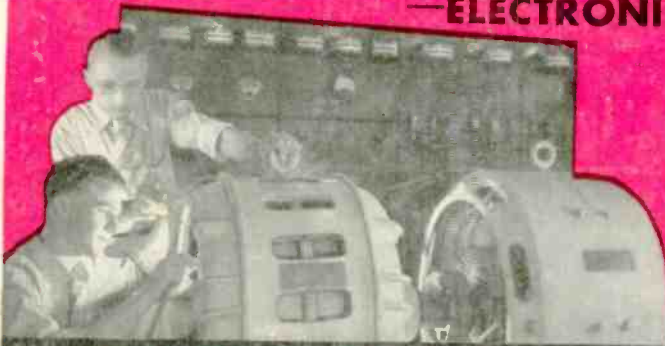

**A.C. and D.C. MOTORS
GENERATORS
SWITCHBOARDS
CONTROLLERS
WIRING JOBS
APPLIANCES
ELECTRONIC UNITS**

(Shown at left—Instructor explaining operation and testing of a large Motor Generator in our A.C. Department.)

AND TELEVISION-RADIO

On Real:

**TELEVISION SETS
RADIO RECEIVERS
F.M.
(Frequency Modulation)
ELECTRONICS
RECORD CHANGERS
AUTO RADIOS
PUBLIC ADDRESS Systems**

(Right—Instructor helping students check the wiring and trace circuits of television receivers.)



Trained Men Needed for Defense and Military Programs

ELECTRICITY—RADIO—TELEVISION—ELECTRONICS—VITAL in defense program. Trained men whether 16 or up to 50 needed. **TRAIN QUICKLY** for better rating if drafted—Vital job in industry if not.

FINANCE PLAN Enroll now, pay most of tuition later. Special plan for men of draft age.

WE TRAIN YOU IN CHICAGO. At Coyne you learn on real, full-size equipment. Trained instructors show you how, then you do typical jobs yourself. We don't teach by mail.

CLIP COUPON NOW for big new illustrated Coyne book. Check whether interested in **ELECTRICITY** or **TELEVISION-RADIO** or both. No obligation; no salesman will call. Get vital facts now!

B. W. COOKE, President

COYNE
SCHOOL

**A TECHNICAL TRADE INSTITUTE
CHARTERED NOT FOR PROFIT
Established 1859
500 S. Paulina Dept. 82-83H
Chicago 12, Illinois**

ELECTRICITY ★ TELEVISION ★ RADIO ★ REFRIGERATION ★ ELECTRONICS

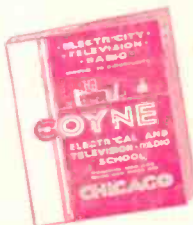

**Mail Coupon for
BIG FREE BOOK!**

**APPROVED
FOR
VETERANS**

**B. W. COOKE, President
COYNE SCHOOL
500 S. Paulina St., Chicago 12, Ill. Dept. 82-83H**

Send **BIG FREE** book and details of your training offer. This does not obligate me and no salesman will call. I am interested in.

ELECTRICITY **TELEVISION-RADIO**

NAME

ADDRESS

CITY.....STATE.....